

INSTRUCTION MANUAL

BIO & PACHY METER

AL-4000

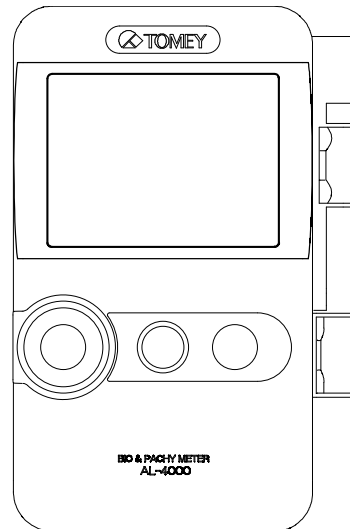

Read this manual thoroughly before using the instrument to ensure proper and safe operation. Contact Tomey Corporation or our local distributor if you have any questions or you encounter any problems during operation.

Note

- *Always follow the operation procedures described in this manual.*
- *Keep this manual in a readily accessible place while operating this instrument.*
- *Contact our local distributor if you lose this manual.*



716A9090-10

i. Important safety information



- **Do not install this instrument in a location where explosives or inflammable substances are used or stored. Fires or explosion may occur.**
- **Do not remove the cover of the instrument. You may be directly exposed to high voltage sections.**
- **Do not disassemble or modify the instrument. You may be directly exposed to high voltage sections.**



- **Disconnect the AC cord from all the connected devices before installing and/or servicing the instrument. Otherwise, you may get an electric shock.**
- **Sterilize measurement probes before use.**
- **Do not use a measurement probe with a damaged contact section. Measurement error may occur, as well as the corneal or eyelid may be injured.**
- **Immersion attachment and disposable tip are a disposable part. Do not reuse these parts. Otherwise, you may contract diseases.**
- **You are cautioned that changes or modifications not expressly approved by the party responsible for compliance could void your authority to operate the equipment.**



- **Do not place water or chemicals on the instrument. Any water or chemicals entering the instrument may cause an electric shock or failure.**
- **Do not allow water or chemicals to splash on measurement probes except for the tips. Any water or chemicals entering the probes may cause an electric shock or failure.**
- **Only use the specified terminal for connection of the instrument. Using another type of terminal may result in failure of the instrument.**
- **This instrument is a measuring device specially designed for ophthalmology. Never use the instrument for other purposes.**
- **The terminal for connecting the instrument to external devices is not isolated from the internal circuit. Inappropriate wiring may damage the internal circuit. Never touch any of these terminals and the patient at the same time. Be sure to contact Tomey or our local distributor before using the external output terminal.**
- **When operating this instrument connected to other devices, only use devices that satisfy IEC60601-1 or equivalent safety requirements, or that conform to IEC60950 and whose power source is insulated with an insulation transformer, in order to satisfy the relevant safety requirements for medical equipment.**



- **Never mark or damage the caution labels on the instrument. The caution labels are provided at two locations as shown below.**
- **If a label is damaged or becomes illegible, please contact Tomey Corporation or our local distributor.**

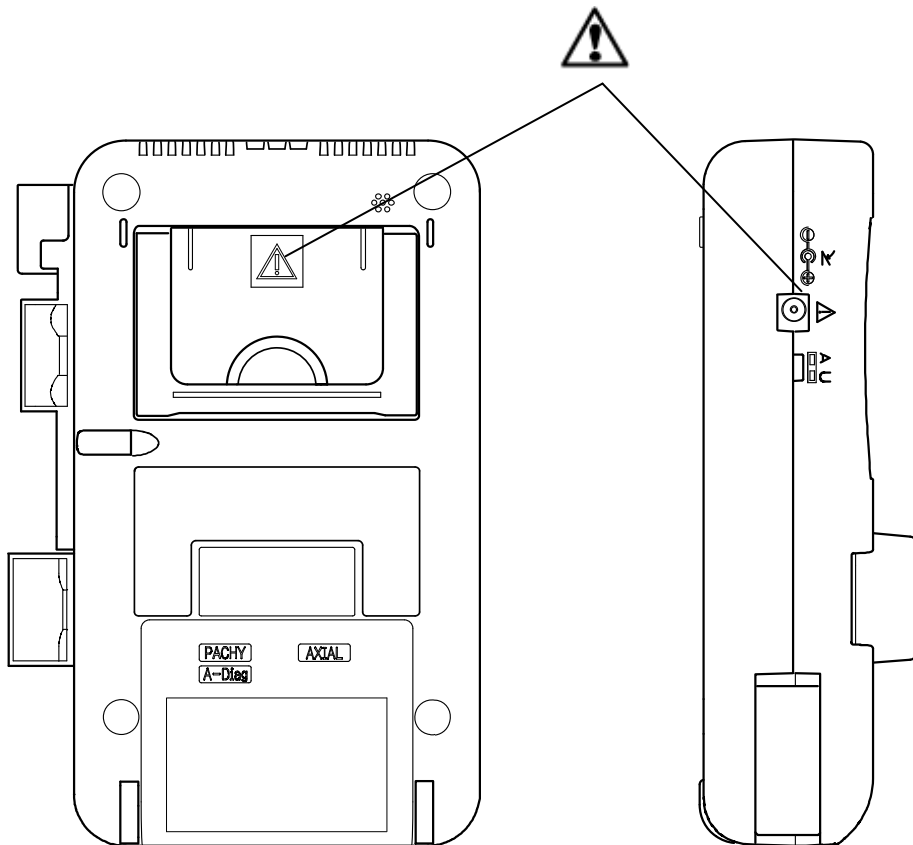



- *This device complies with FCC RF radiation exposure limits set forth for an uncontrolled environment. The antenna used for this transmitter must be installed to provide a separation distance of at least 20 cm from all persons and must not be co-located or operated in conjunction with any other antenna or transmitter.*
-



This page is intentionally blank

ii. How to read this manual

Outline

This manual is structured as follows.

1. **PRIOR TO USE**

Describes safety precautions and important information to be understood before installing and using the instrument.

2. **NAMES AND FUNCTIONS**

Describes names and functions of each section of the instrument.

3. **OPERATION PROCEDURES**

Describes information required for installing and using the instrument.

4. **TECHNICAL INFORMATION**

Describes useful technical information about the instrument.

5. **INSPECTION AND MAINTENANCE**

Describes procedures for replacing consumable parts, etc. that the user of the instrument should normally conduct.

6. **TROUBLESHOOTING**

Describes how to solve problems.

7. **CONSUMABLES AND OPTIONAL EQUIPMENT**

Describes consumable parts and optional equipment.

8. **SPECIFICATIONS**

Describes the specifications of the instrument.

9. **INDEX**

Refer to the index when needed.

Symbols used in this manual

Sentences accompanied with the symbols below indicate the following:



- *This is a precaution that, if unheeded, will result in a hazardous situation where there is imminent danger of serious injury or death.*



- *This is a precaution that, if unheeded, could result in a hazardous situation where there is a possibility of serious injury or death.*



- *This is a precaution that, if unheeded, may result in a situation where there is a possibility of minor or moderate injury or damage to property.*



- *This is an additional instruction which may contain a special precaution on company policy related, either directly or indirectly, to the safety of personnel or to the protection of property.*

iii. Table of contents

i. Important safety information	i-1
ii. How to read this manual.....	ii-1
Outline.....	ii-1
Symbols used in this manual.....	ii-2
iii. Table of contents	iii-1
1. PRIOR TO USE.....	1-1
1.1 Precautions for operation.....	1-1
1.2 Glossary	1-6
1.3 Checking package contents.....	1-8
1.4 Overview	1-9
2. NAMES AND FUNCTIONS	2-1
2.1 Front of the main unit.....	2-1
2.2 Back of the main unit.....	2-3
2.3 Sides of the main unit.....	2-4
2.4 Top of the main unit.....	2-5
2.5 Bottom of the main unit	2-6
2.6 Screen	2-7
2.6.1 Basic structure and common items	2-7
2.6.2 Axial Length Measurement (Biometry)	2-9
2.6.3 Corneal thickness measurement.....	2-15
2.6.4 Diagnosis in mode A.....	2-17
2.7 Auto power off function	2-20
3. OPERATION PROCEDURES	3-1
3.1 Safety precautions	3-1
3.1.1 Precautions for installing the instrument.....	3-2
3.1.2 Precautions for connecting the power	3-3
3.2 Preparation before use.....	3-4
3.2.1 Connections	3-4
3.2.2 Wireless connection with UD-8000 and IOL calculation unit.....	3-12
3.2.3 Turning the power on and adjustment after turning the power on.....	3-16
3.2.4 Switching modes.....	3-18
3.2.5 Setting measurement conditions	3-19
3.2.6 Entering the patient data.....	3-19

3.2.7	Clear all measurement data (preparation for measuring a new patient).....	3-22
3.2.8	Selecting the eye to be measured	3-23
3.3	Axial length measurement function.....	3-24
3.3.1	Connecting the biometry probe	3-24
3.3.2	Setting axial length calculation method and converted acoustic velocity for eye to be measured	3-24
3.3.3	Contact/immersion mode settings	3-29
3.3.4	Operation check.....	3-29
3.3.5	Preparation for measurement.....	3-29
3.3.6	Precautions for measurement	3-30
3.3.7	Measurement	3-40
3.3.8	Checking waveforms after measurement.....	3-45
3.4	IOL power calculation.....	3-53
3.4.1	Calculation	3-53
3.4.2	Setting calculation conditions	3-53
3.4.3	Entering calculation parameters	3-53
3.4.4	Setting calculation formula.....	3-59
3.4.5	Saving measurement data.....	3-60
3.5	Pachymetry function.....	3-61
3.5.1	Connecting the pachymetry probe.....	3-61
3.5.2	Setting the data type to be displayed	3-61
3.5.3	Setting how to display the converted acoustic velocity and bias value.....	3-61
3.5.4	Setting the measurement mode/range and data display.....	3-63
3.5.5	Operation check.....	3-65
3.5.6	Preparation for measurement.....	3-65
3.5.7	Measurement	3-66
3.5.8	Checking the measurement data.....	3-73
3.5.9	Saving the measurement data.....	3-76
3.6	A-scan diagnosis	3-77
3.6.1	Connecting the probe	3-77
3.6.2	Switching to the A-scan diagnosis	3-77
3.6.3	Gain setting.....	3-79
3.6.4	Setting analysis method.....	3-80
3.6.5	Measurement	3-81
3.6.6	Various functions in FREEZE mode	3-82
3.6.7	Various functions in real time mode.....	3-85
3.6.8	Analysis function	3-86

3.7	Utilities	3-90
3.7.1	Buttons and icons on the screen	3-91
3.7.2	Operations for each setting.....	3-95
4.	TECHNICAL INFORMATION	4-1
4.1	IOL power calculation formula.....	4-1
4.1.1	SRK-II formula	4-1
4.1.2	SRK/T formula	4-2
4.1.3	HOLLADAY formula	4-4
4.1.4	Hoffer Q formula	4-6
4.1.5	HAIGIS standard formula.....	4-7
4.2	How to calculate axial length using the axial length measurement function	4-9
4.2.1	Phakic eye	4-9
4.2.2	Dense cataract eye	4-9
4.2.3	Aphakic eye	4-9
4.2.4	IOL eye.....	4-10
4.3	Amplifier characteristics of the A-scan diagnosis	4-11
4.4	Checking the software version.....	4-11
4.5	Ultrasound wave output	4-12
4.5.1	MI (mechanical index).....	4-12
4.5.2	TIS (thermal index of soft tissue).....	4-12
5.	INSPECTION AND MAINTENANCE	5-1
5.1	Warranty	5-1
5.2	Durable years	5-2
5.3	Inspection	5-2
5.4	Routine maintenance	5-2
5.4.1	Maintenance of measurement probes.....	5-3
5.4.2	Cleaning and Disinfection of measurement probes (for Europe).....	5-6
5.4.3	Maintenance of main unit.....	5-8
5.5	Replacing consumables	5-9
5.6	Storing	5-9
5.7	Disposal.....	5-10
6.	TROUBLESHOOTING	6-1
7.	SPARE PARTS AND OPTIONAL PARTS	7-1
7.1	Spare parts	7-1
7.2	Optional parts	7-1

8. SPECIFICATIONS.....	8-1
8.1 Specifications	8-1
8.1.1 Biometry/IOL power calculations	8-1
8.1.2 Function of pachymetry	8-2
8.1.3 A-scan Diagnosis.....	8-3
8.1.4 Main unit.....	8-3
8.1.5 AC adapter.....	8-3
8.1.6 Battery.....	8-3
8.2 Energy and other consumption.....	8-4
8.2.1 Influences of ultrasound energy on the human body	8-4
8.2.2 Ultrasound energy.....	8-5
8.3 Noise	8-10
8.4 Environment conditions.....	8-10
8.5 Classification of ME Equipment	8-11
8.6 Declaration of Conformity to EMC	8-12
9. INDEX.....	9-1

1. PRIOR TO USE

Note

- *Read this manual thoroughly before using this instrument to ensure proper and safe operation.*
- *Always follow the operation procedures described in this manual.*
- *Do not place any other objects on this instrument.*
- *Check that there are no devices that generate strong magnetic field near the instrument. A strong magnetic field may cause noise and affect measurement.*

1.1 Precautions for operation

- *When measuring the axial length, fully examine the measured data for waveforms and variations. If the measurement result is doubtful, perform measurement again or another inspection to review the inspection result. If incorrect measurement data is used to select intraocular lenses, further surgery might be required.*
- *When using the IOL calculation result to select intraocular lenses, thoroughly determine the selection by also examining cataract surgery methods and other inspections.*
- *When measuring corneal thickness, the measurement accuracy may exceed $\pm 5 \mu\text{m}$ depending on the conditions of measurement or patient's corneal. Carefully consider the history of corneal diseases and surgeries, and review the inspection result by performing measurement again or another inspection if the measurement result is doubtful.*
- *Only allow qualified operators to use the instrument.*
- *Artifacts may occur in the ultrasonic measurements. If measurement values are questionable, determine the values by overall judgment (using the wave forms or results from other equipment).*

■ **Precautions when installing the instrument and accessories**



- *Install the instrument in a location free of water or chemicals. Any water or chemicals entering the instrument or devices may cause an electric shock or failure.*
- *Do not install the instrument in a location where chemicals are stored or gases may occur. Any chemicals or vapor entering the devices may result in fire.*
- *Check that the frequency, voltage, and allowable current (or power consumption) of the power source are appropriate. Otherwise, fire or electric shock may occur.*
- *Do not place any heavy object on the AC cord or squash the power cord. Fire or electric shock may occur.*
- *Fully insert the power plug into the outlet. Faulty contact, allowing any metal to contact the exposed terminal of the plug, or dust accumulated on the exposed terminal of the plug may result in fire or electric shock.*
- *Do not connect a device with data transmission specifications that are not compatible. Fire or electric shock may occur. Contact Tomey Corporation or our local distributor before using the instrument while connected to another device.*



- *Install the instrument in a location not subject to direct sunlight, high temperature and humidity, or air containing dust, salt, and/or sulfur. Otherwise, failure or malfunction may occur.*
- *Install the instrument in a leveled stable location free of vibration or mechanical impact. Otherwise, measurement cannot be conducted correctly. Also, the instrument may topple over or fall down, resulting in fire or a serious accident.*
- *Install the instrument in a location with ample clearance from other devices to allow smooth inspection.*
- *Check that the frequency, voltage, and allowable current (or power consumption) of the power source are appropriate.*
- *Check the power source (discharge condition, polarity, etc.).*

-
- *A magnet is built into the instrument. Do not place any electronic device, magnetic card, and other objects that may be affected by magnetism near the instrument. These may become unusable.*

■ **Precautions before operation**



- *Check the electrical contact of switches, polarity, dial setting, and meters, and that the instrument is working correctly.*
- *Check that all cables are connected correctly.*
- *Do not allow water or chemicals to splash on measurement probes, except for the tips. Any water or chemicals entering the probes may cause an electric shock or failure.*
- *Check the sections that the patient will directly touch.*
- *Check that the date set in the instrument conforms to the actual operation date and time.*

■ **Precautions during operation**



- *Do not place any container with liquid in it on the instrument. Any liquid entering the instrument may cause electric shock or failure.*
- *Be sure to touch the “New” button on the main unit to delete the measurement data for the previous patient before measuring a new patient. If new measurement is started without deleting the previous data, the measurement data for the previous patient may be included.*
- *Do not allow the patient to touch the terminals for connecting the instrument to external devices.*



- *Do not press on the instrument from the top. Doing so may cause failure of the instrument.*
- *Do not allow water or chemicals to splash on probes, except for the tips. Any water or chemicals entering the probes may cause an electric shock or failure.*
- *Be extremely careful not to take too much time or too many measurements, as this can stress the patient.*

-
- *Constantly observe that both the instrument and patient are free of problems.*
 - *If a problem with the instrument or the patient occurs, take appropriate action, such as stopping the device, to ensure the patient's safety.*
 - *Do not allow the patient to touch the instrument.*
 - *If any smoke, offensive odor, or abnormal sound occurs, turn off the instrument immediately, disconnect the power plug from the outlet, and contact our local distributor or Tomey Corporation.*

■ **Precautions after operation**



- *Do not place any container with liquid in it on the instrument. Any liquid entering the instrument may cause electric shock or failure.*



- *Do not use organic solvents such as thinner, benzene, or acetone to clean the instrument. Fire or electric shock may occur. (These solvents may also corrode the resin or coating on the cover of the instrument.)*
- *Follow the specified procedures to return the operation switch, dial, etc. to their original positions and turn the instrument off.*
- *Hold the plug when disconnecting the power plug from the outlet to avoid placing excessive force on the cord. Pulling the cord may damage the inner core wires, resulting in electric shock or fire.*
- *When disconnecting cords, do not apply too much force to them, for example, do not hold and pull the cord.*
- *Refer to "5.6 Storing" for instructions on the storage of the instrument.*
- *Clean the instrument at the end of operation in preparation for the next use.*
- *Clean and neatly arrange the accessories and cables.*

-
- ***If any failure occurs in the instrument, immediately stop operation, identify the failure in the instrument, and contact our local distributor for repairs.***



- *Do not modify the instrument. Doing so may cause electric shock or failure of the instrument. There is a high-voltage section in the instrument. Touching this section will result in death or serious injuries.*



- *Use the AC cord provided with the instrument or one specified by Tomey to ensure safety. Also, do not use the accessories provided with the instrument for other equipment.*



- *Conduct regular inspections of the instrument and components. When the instrument is not used for 1 month or longer, check that the instrument is operating correctly and safely before starting operation. Refer to “5.3 Inspection” in this manual for the relevant procedures.*

1.2 Glossary

[ACD]	:	Anterior chamber depth
[Acrylic]	:	Acrylic lens
[Aphakic]	:	Aphakic eye
[AVG]	:	Average value
[Axial]	:	Axial length measurement (biometry)
[A-Diag]	:	A-scan diagnosis
[BD address]	:	Bluetooth® Device Address Number set to each device to identify the connection
[Bluetooth ®]	:	Registered mark of Bluetooth SIG, Inc.
[Calibration]	:	Calibration of the pachymetry probe
[CCT]	:	Corneal center thickness
[Contact]	:	Method of taking measurements by directly applying the contact section of the biometry probe to the center of the corneal
[D]	:	Diopter The unit of refractive power representing the level of myopia, hyperopia, or astigmatism. Reciprocal of the focal length measured in meters.
[FREEZE]	:	Status where ultrasound waves are not transmitted
[Immersion]	:	Method of taking measurements by applying corneal protective agent between the corneal and contact section of the biometry probe, or attaching a special tool to the eye and using water between the corneal and contact section.
[IOL]	:	Intraocular lens
[K1]	:	Radius of corneal curvature of minor meridian [mm]
[K2]	:	Radius of corneal curvature of major meridian [mm]
[Obj.]	:	Section to be measured
[Pachy]	:	Corneal thickness measurement
[Pre]	:	Before refractive power correction surgery
[Phakic]	:	Phakic eye
[PMMA]	:	PMMA lens
[Post]	:	After refractive power correction surgery
[Ref.]	:	Reference section
[Silicone]	:	Silicone lens
[US]	:	Ultrasound biometry

[Auto power off function]	:	The power turns off automatically when no operation is conducted for a specified time.
[Caliper]	:	Manually moves the measurement point.
[Gain]	:	Adjusts amplification and amplitude of waveforms.
[Gate]	:	Specifies the range of waveforms to be detected.
[Measurement point]	:	Indicates the point where corneal thickness is measured by diameters and angles.
[Touch panel]	:	Allows you to make various settings, etc. by directly touching the monitor.
[Bias value]	:	Value obtained by converting actual measurements using a specified percentage or correction value

1.3 Checking package contents

Open the package and check that the required quantity of the following items is included and they are not damaged. If any item is missing or damaged, contact our local distributor as soon as possible.



■ ***Keep the box and packing materials for use when moving or transporting the instrument.***

- Main unit BIO & PACHY METER AL-4000..... 1
- Biometry probe (with protective cap and the case)..... 1
- Footswitch..... 1
- AC adapter 1
- AC cord..... 1
- Biometry Test piece 1
- Immersion attachment (20pcs/box)..... 1
- USB cable..... 1
- Sleeve for eye axis probe..... 1
- Probe holder 1
- Touch pen 1
- Carrying bag 1
- Dust cover 1
- Instruction manual (this manual) 1
- Installation manual for TB-1000 1
- Installation CD for TB-1000 1

1.4 Overview

- This instrument is a device used in ophthalmology to measure the distance between living tissue, utilizing ultrasound waves generated from the ultrasound transducer built into the measurement probe. This device is designed to measure the axial length and corneal thickness at optical clinics. The A-scan diagnosis allows you to identify areas with pathological changes by observing mode-A waveforms.
- Transmission of ultrasound waves is stopped when waveforms freeze.
- The measurement probe connected to this instrument transmits ultrasound waves to the inside of the eyeball and then receives ultrasound echoes reflected by the tissue boundary surface in the eyeball.
- The time required for the ultrasound wave to be transmitted from the front of the corneal to the measurement section is measured, and the length of the living tissue is calculated based on the preset converted acoustic velocity.

$$L = \frac{V \cdot t}{2}$$

L: Length of living tissue
V: Converted acoustic velocity
t: Measurement time

- This instrument is equipped with an automatic measurement function and sound monitor function, as well as functions for measuring axial length and corneal thickness, for ease of operation by the physician.
- This instrument adopts the SRK/T II, SRK/T, HOLLADAY, Hoffer Q, and HAIGIS standard as the IOL power formula, and the IOL power can be calculated immediately after measuring axial length.
- The measurement data can be saved in the internal memory.



This page is intentionally blank

2. NAMES AND FUNCTIONS

2.1 Front of the main unit

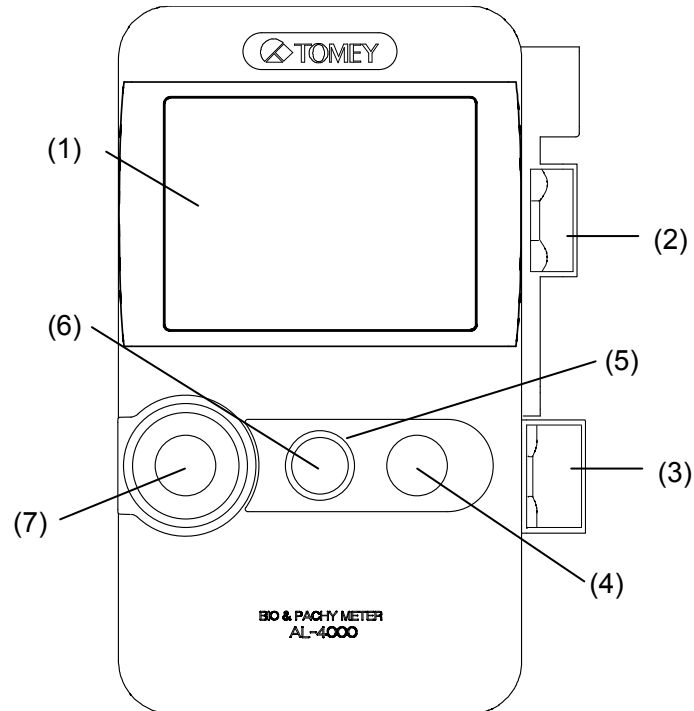

(1) LCD and touch panel

Measurements, waveforms, and IOL calculation results are displayed on the 3.5" TFT color LCD (320 x 240 dots). Operations are performed by touching buttons on the touch panel attached over the LCD.

(2) Pachymetry probe holder

Holder for the pachymetry probe

(3) Probe holder (small)

Holder for the biometry/A-scan diagnosis probe

(4) "Mode" button

Switches the axial length measurement function and pachymetry function.

(5) Power LED

Turns on when power is supplied to the main unit.

Lit orange while charging.

(6) Power switch

Turns the instrument on and off.

(7) Gain adjustment knob

Knob to adjust the gain

2.2 Back of the main unit

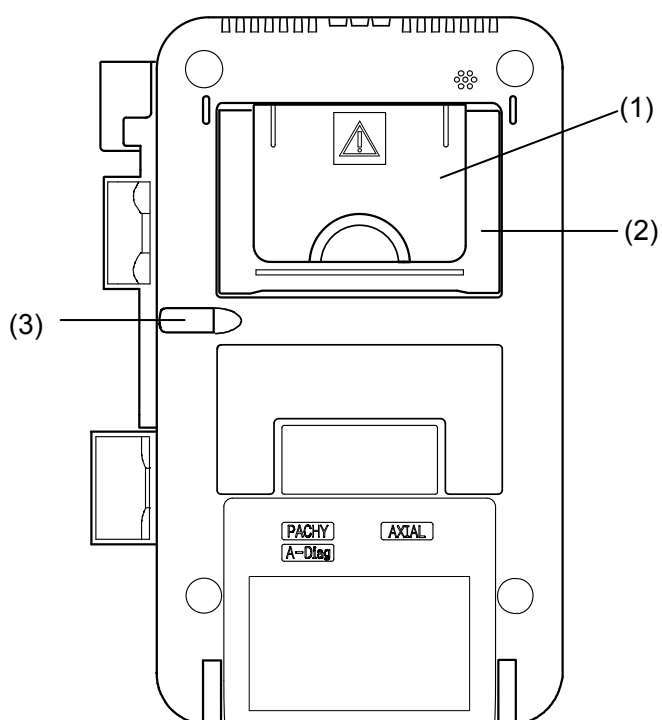

(1) Battery cover

Open this cover when replacing the built-in battery.

(2) Stand

Stand to hold the main unit at an angle

(3) Touch pen

Used when operating the touch panel.

2.3 Sides of the main unit

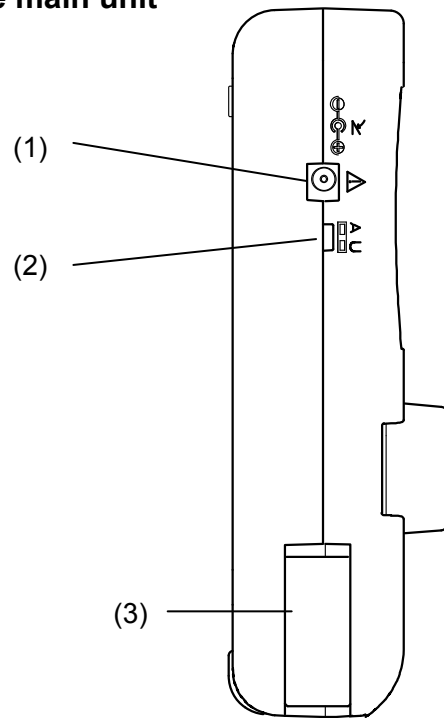

(1) AC adapter/footswitch connector

Connect the AC adapter and footswitch here.

(2) Maintenance switch

Our service personnel use this switch for maintenance.

(3) Cable hook

Wind the probe cable that can be stored in the main unit here.

2.4 Top of the main unit

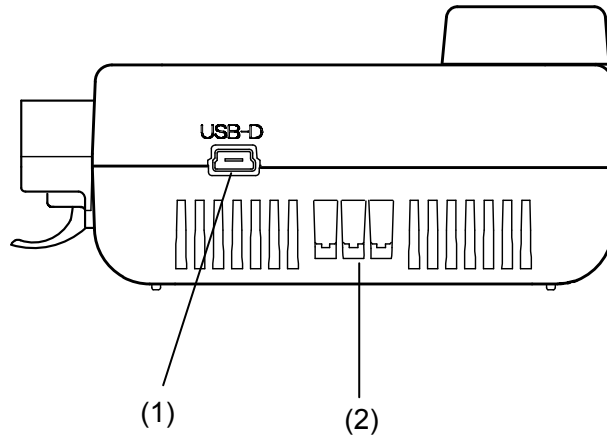

(1) USB connector

Connect the personal computer and IOL calculation unit here.

(2) Power supply terminal

Receives power supplied from UD-8000.

2.5 Bottom of the main unit

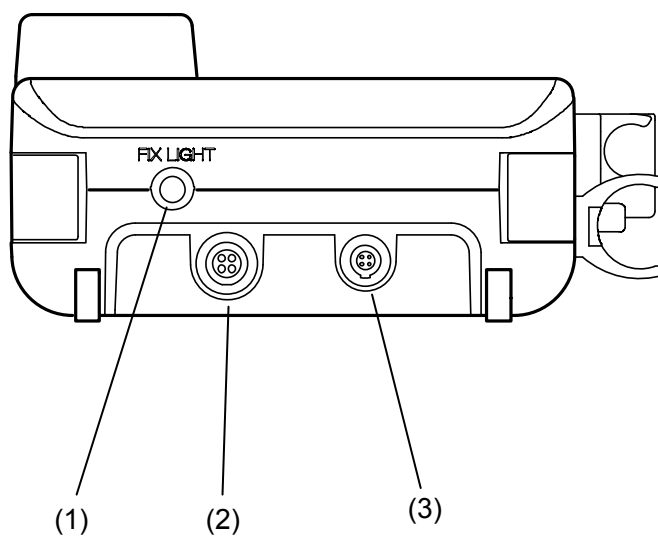

(1) Connector for fixlight

Connect the external fixlight of the special chin rest here.

(2) Biometry probe connector

Connect the biometry probe here.

(3) Corneal thickness/A-scan diagnosis probe connector

Connect the pachymetry probe or A-scan diagnosis probe here.

2.6 Screen

2.6.1 Basic structure and common items

The dark area varies depending on operation modes.

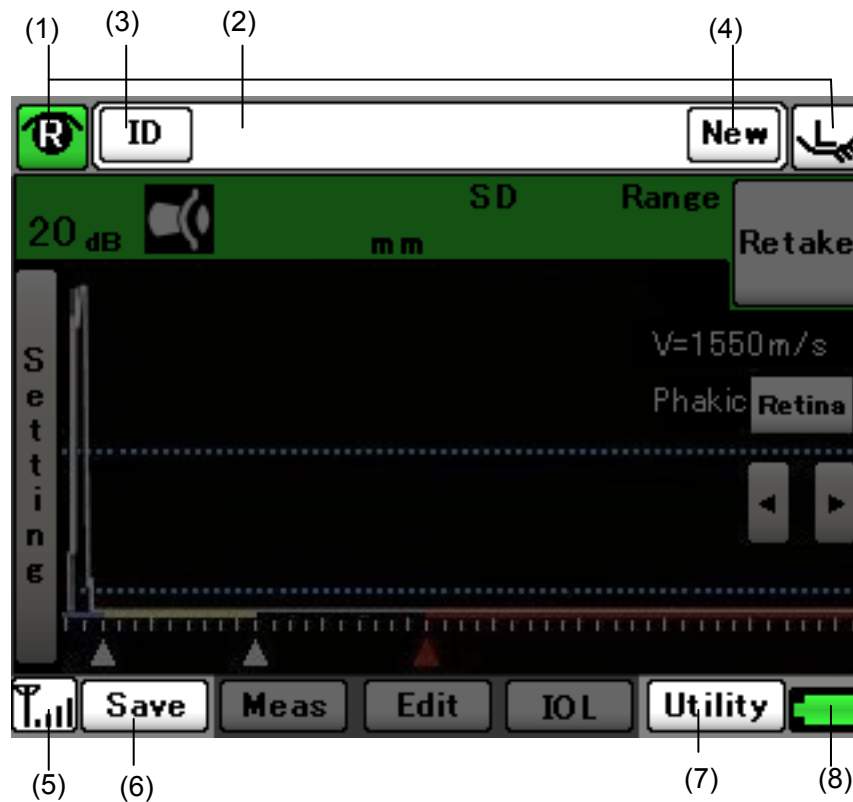

(1) Inspected eye

Touch the “R” or “L” button to display the measurement screen for the selected eye (right or left).

(2) Patient information field

Displays the patient ID entered on the patient information entry screen.

(3) “ID” button





Opens the patient information entry screen.

(4) “New” button

Deletes all measurement data and patient information for both eyes, and returns to the initial measurement screen.

(5) Communication status button

Displays the communication status as an icon.

Communicating via wireless access	:		
Communicating via USB	:		
Communication stopped	:		
Communication not possible	:		* Operations not possible.

Utility operations are required for connection.

(6) "Save" button

Saves the measurement data in the AL-4000 measurement unit.

(7) "Utility" button

Opens the utility screen.

(8) Battery indicator

Shows the battery status.

2.6.2 Axial Length Measurement (Biometry)

a) Measurement screen

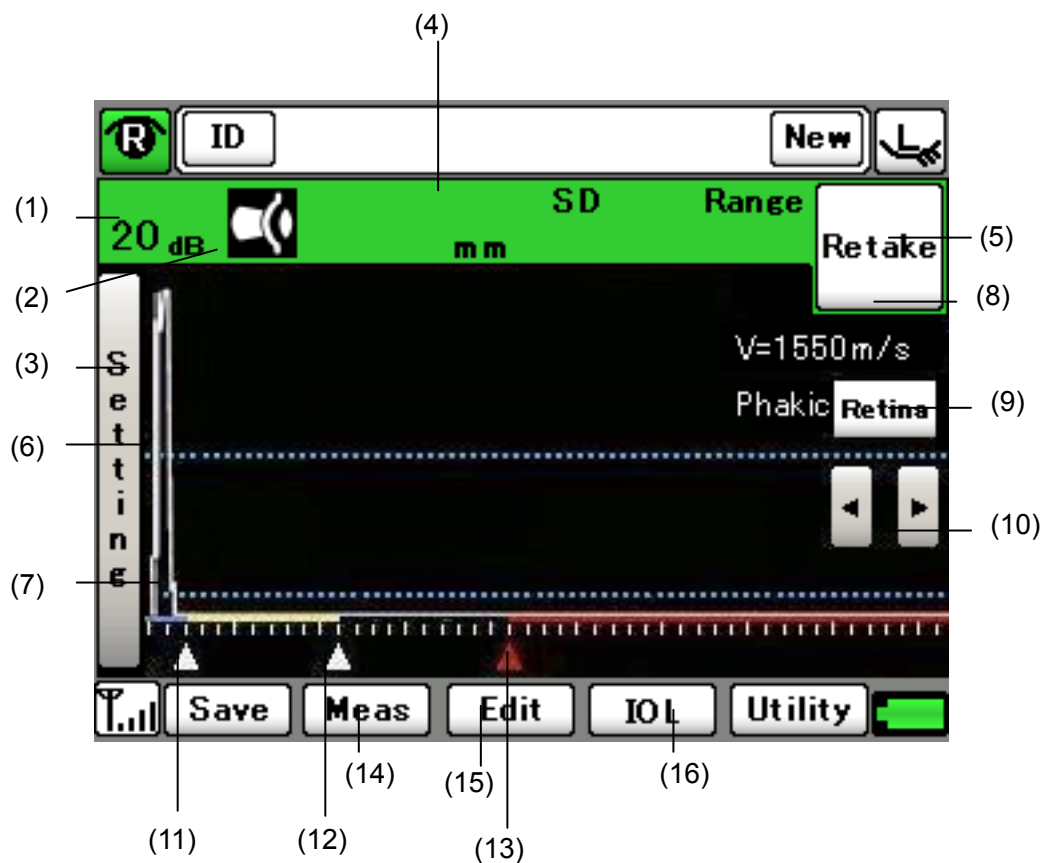

(1) Gain indicator

Displays the gain.

(2) Mode display

Displays the mode set on the utility screen (contact or immersion).

(3) "Setting" button

Displays the measurement condition setting menu.

(4) Axial length data display

Displays the average, standard deviation, and data range of the axial length.

(5) "Retake" button

Deletes the measurement data currently displayed and opens the measurement screen for the same eye.

(6) Level cursor/level line

Measurement data will be taken when the waveform rises above this cursor/line position.

(7) Measurement cursor/measurement line

The distance at this cursor/line should be taken as the measurement data.

(8) Average acoustic velocity

Displays the average acoustic velocity when calculating the axial length.

(9) Cursor button

Switches the active gate cursor.

Corneal -> LensF (front of lens) -> LensR (back of lens) -> Retina

(10) Gate cursor movement button

Moves the active gate cursor.

(11) Gate cursor for the front of lens

The waveform on the right of this cursor position is measured as the waveform of the front of the lens.

(12) Gate cursor for the rear of lens

The waveform on the left of this cursor position is measured as the waveform of the rear of the lens.

(13) Retina gate cursor

The waveform on the right of this cursor position is measured as the waveform of the retina.

(14) "Meas (measurement)" button

Displays the measurement screen.

(15) "Edit" button

Opens the edit screen.

(16) "IOL" button

Opens the IOL power calculation screen.

b) Edit screen (data list)

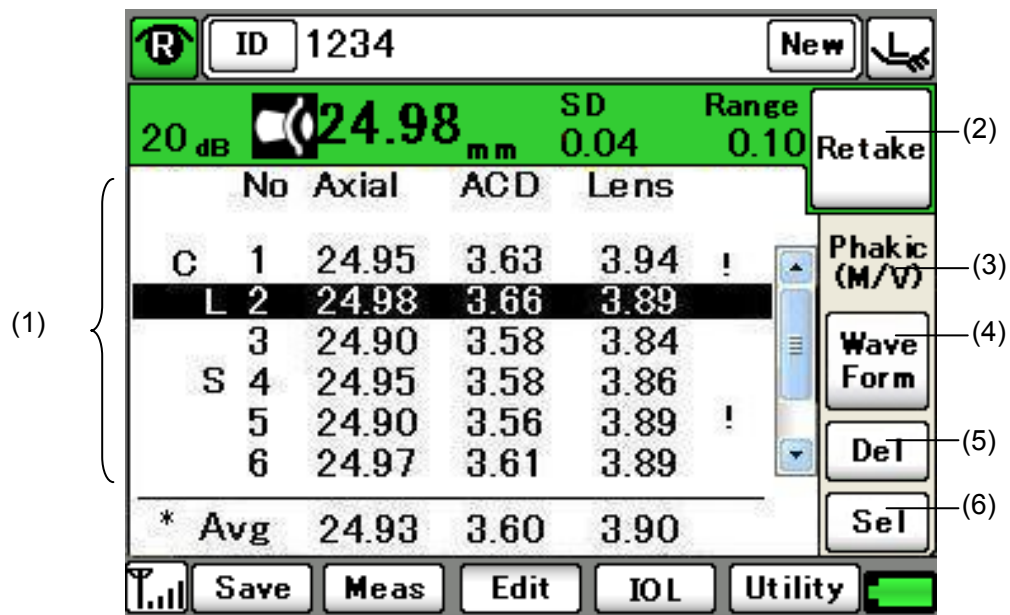

(1) Measurement data display

Measurement data of the axial length, anterior chamber depth, and crystal lens thickness, and their averages are listed. The following marks are assigned to the measurement data.

“*”: Data used for calculating IOL

L : Longest axial length

S : Shortest axial length

C : Calipered data

“!” : Indicates only when wave form appears at more than 1mm away from Retina spike wave form.

(2) “Retake” button

Deletes only the displayed measurement data and takes another measurement.

(3) Eye type to be measured

Displays the current eye type to be measured.

(4) “Wave Form” button

Opens the edit screen (waveform).

(5) “Del/Ret” button

Deletes or retakes the data.

(6) "Sel (select)" button

Selects the data at the cursor position to be used for calculating the IOL. "*" is assigned to the selected data.

c) Edit screen (waveform)

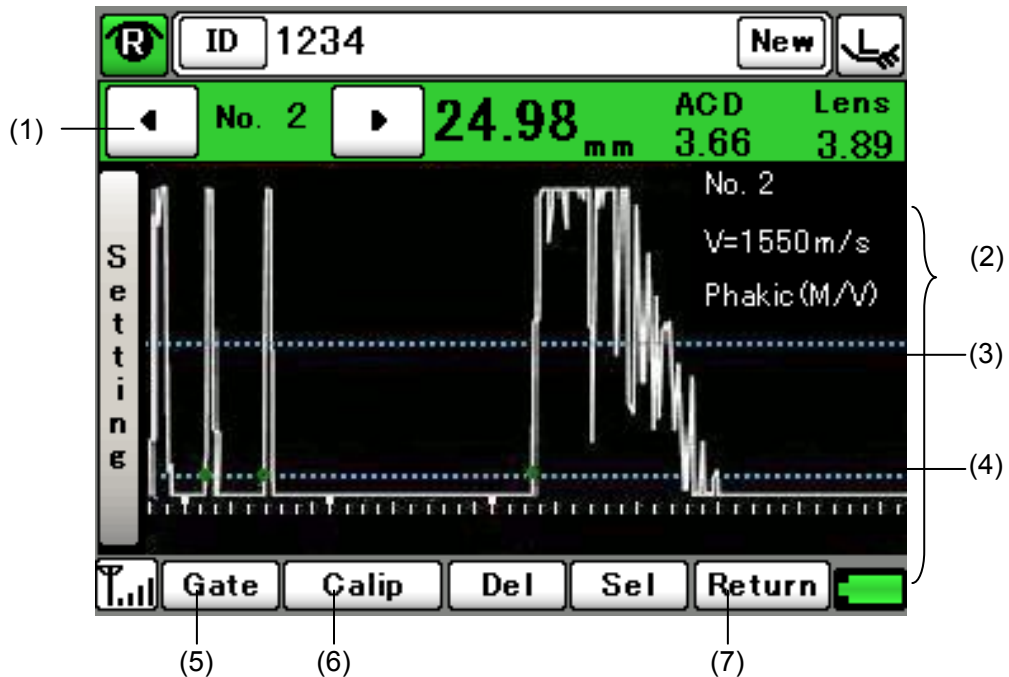

(1) Memory number selection key

Touch these buttons to select the memory number of the measurement data.

(2) Waveform, memory number, mean velocity, and eye type of the selected measurement data

The waveform, memory number, mean velocity, and eye type of the selected measurement data is displayed.

(3) Level cursor/level line

Measurement data will be taken when the waveform is above this cursor position in auto measurement mode.

(4) Measurement cursor/measurement line

The distance at this measurement position should be the measurement data. The measurement point is indicated with “●.”

(5) “Gate” button

Opens the gate change screen.

(6) “Calip (caliper)” button

Opens the caliper screen.

(7) “Return” button

Returns to the edit screen (data list).

d) IOL calculation screen

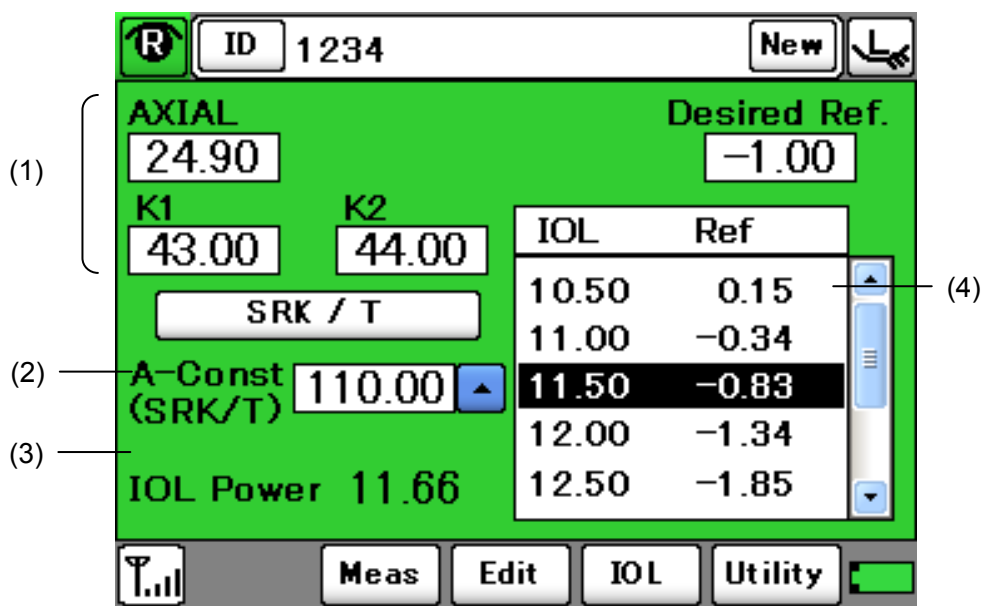

(1) Parameter field

Enter the following parameters used for calculating IOL power.

Axial length / anterior chamber depth / K1 (mm or D) / K2 (mm or D) / Desired refractive power.

The anterior chamber depth is displayed only when “HAIGIS standard formula” is selected.

(2) A-Const (lens constant)

Enter the appropriate lens constant for the formula.

(3) IOL Power

The IOL power that satisfies the “desired refractive power after surgery” is displayed.

(4) IOL standard and estimated refractive power after surgery

The IOL standards based on calculation results and estimated refractive power after surgery to implant the IOL are listed.

2.6.3 Corneal thickness measurement

a) Measurement screen

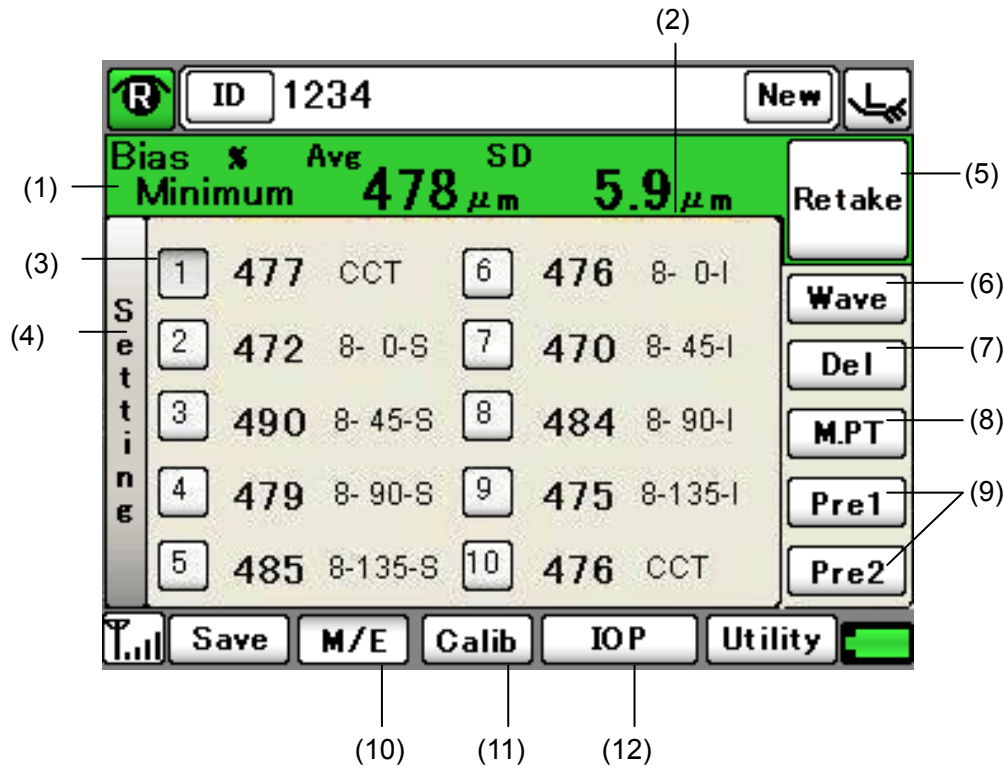

(1) Setting display

The bias value and types of data to be displayed are listed.

(2) Average and standard deviation of corneal thickness

The average and standard deviation of the corneal thickness data is displayed.

(3) Measurement data display

The memory number, measurement data, and measurement point are displayed.

(4) "Setting" button

Shows the measurement condition setting menu.

(5) "Retake" button

Deletes the measurement data currently displayed and opens the measurement screen for the same eye.

(6) “Wave Form” button

Displays the waveform of the selected memory number.

(7) “Del/Ret” button

Deletes or retakes the data.

(8) “Meas Point (measurement point)” button

Shows and hides measurement points.

(9) “Pre 1”/“Pre 2” buttons

These buttons appear when the “Meas Point” button is touched and allow you to show the contents preset for the selected measurement point in the measurement data field.

(10) “M/E” button

Displays the measurement/edit screen.

(11) “Calib (calibration)” button

Calibrates the sensitivity of pachymetry probes.

(12) “IOP” button

Displays the intraocular pressure correction screen.

2.6.4 Diagnosis in mode A

a) Measurement screen (real time)

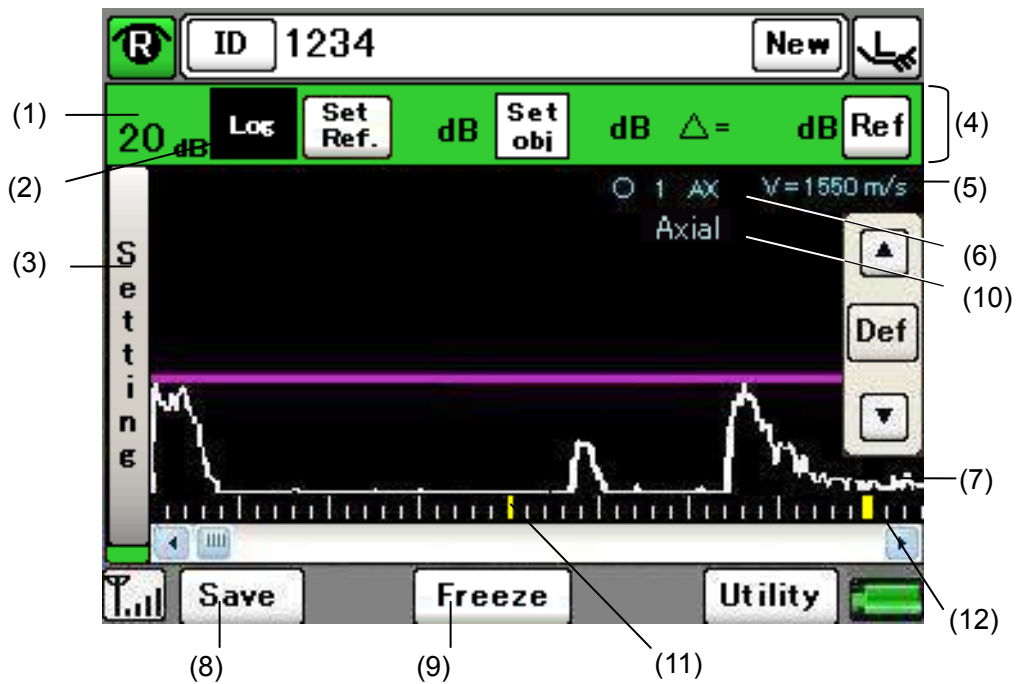

(1) Gain display

The gain setting is displayed.

(2) Log (gradation characteristics)

The gradation characteristics are displayed.

(3) "Setting" button

Shows the measurement condition setting menu.

(4) Analysis tool

Analyzes waveforms of the measurement data.

(5) Converted acoustic velocity

The acoustic velocity for conversion is displayed.

(6) Probe position

The point to which the probe is applied and the direction of ultrasound beams are displayed.

(7) Measurement waveform

The mode-A waveform is displayed.

(8) "Save" button

Saves the measurement data in the AL-4000 measurement unit.

(9) "FREEZE" button

Changes the mode from real time to freeze.

(10) Probe display

The probe type currently applied is shown.

(11) Scale 1

The 20-mm point is indicated with a 1-dot-wide yellow line.

(12) Scale 2

The 40-mm point is indicated with a 2-dot-wide yellow line.

b) Measurement screen (FREEZE)

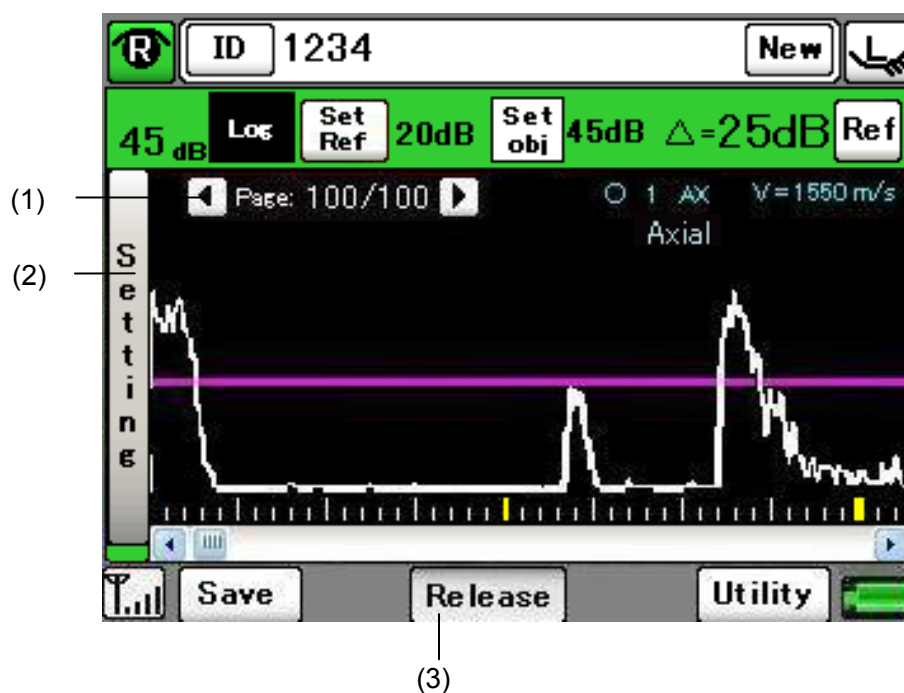

(1) Page button and page number display

Changes each data of the captured mode-A waveform. The page number currently displayed is shown.

(2) "Edit" button

Displays the edit menu.

(3) "Release" button

Changes the mode from freeze to real time.

2.7 Auto power off function

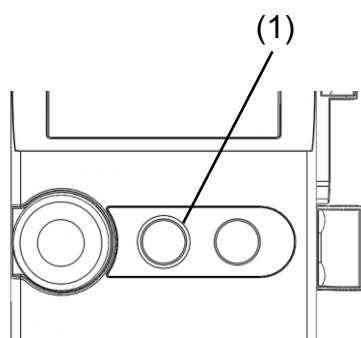

(Fig. 1)

This function automatically turns off the LCD when the instrument is not operated for a specified time. Touch the monitor to return to normal status. When the AC adapter is not connected, the power is automatically turned off when the specified time has passed after the auto power off function was activated. Turn on the power to resume measurement. Refer to “3.2.3 Turning the power on and adjustment after turning the power on.”

3. OPERATION PROCEDURES

3.1 Safety precautions



- *Sterilize measurement probes before use.*
- *Do not use a measurement probe with its contact section damaged. Measurement error may occur, additionally the corneal or eyelid may be injured.*
- *The immersion attachment is a disposable part. Do not reuse it. Otherwise, you may contract diseases.*



- *This instrument is a measurement device specifically designed for ophthalmology. Never use the instrument for other purposes.*
- *Only use the specified terminal for connection of the instrument.*
- *Attach the protective cap to the measurement probe and place it in the probe holder when not in use.*

3.1.1 Precautions for installing the instrument



■ *Install the instrument in a location free of water or chemicals. Any water or chemicals entering the instrument may cause an electric shock or failure.*

■ *Do not install the instrument in a location where chemicals are stored or gases may occur. Spilt chemicals or vapor may enter the instrument and result in fire.*



■ *Install the instrument in a location not subject to direct sunlight, high temperature and humidity, or air containing dust, salt, and/or sulfur. Otherwise, failure or malfunction may occur.*

■ *Install the instrument in a leveled stable location free of vibration or mechanical impact. Otherwise, measurement cannot be conducted correctly. Also, the instrument may topple over or fall down, resulting in fire or a serious accident.*

■ *Install the instrument so that the user can use the system under optimal conditions. Carefully connect the devices so that the wiring is not disconnected unintentionally during operation, and does not hinder operation of the instrument.*

3.1.2 Precautions for connecting the power



- *Check that the frequency, voltage, and allowable current (or power consumption) of the power source are appropriate. Otherwise, fire or electric shock may occur.*
- *Do not place any heavy object on the AC cord or squash the power cord. Fire or electric shock may occur.*
- *Fully insert the power plug into the outlet. Faulty contact, allowing any metal to contact the exposed terminal of the plug, or dust accumulated on the exposed terminal of the plug may result in fire or electric shock.*
- *The power plug completely isolates the instrument from the commercial power source. If there is a problem with the instrument, turn off the power switch and disconnect the power plug. Install the instrument in a place where this can be performed smoothly.*
- *Charge the instrument in a stable location. When the instrument is placed on an angle or in an unstable location, the instrument may fall, resulting in injuries or breakage.*

3.2 Preparation before use

3.2.1 Connections

Note ■ *Faulty connection of the instrument and relevant accessories may result in fire, electric shock, or fatal accident. Turn off all devices and disconnect the power plugs from the outlet before connection.*

■ *The connector needs to be inserted in a specific direction. Check the direction and firmly insert the connector.*

a) Connecting the AC adapter

Note ■ *Always use the specified AC adapter.*

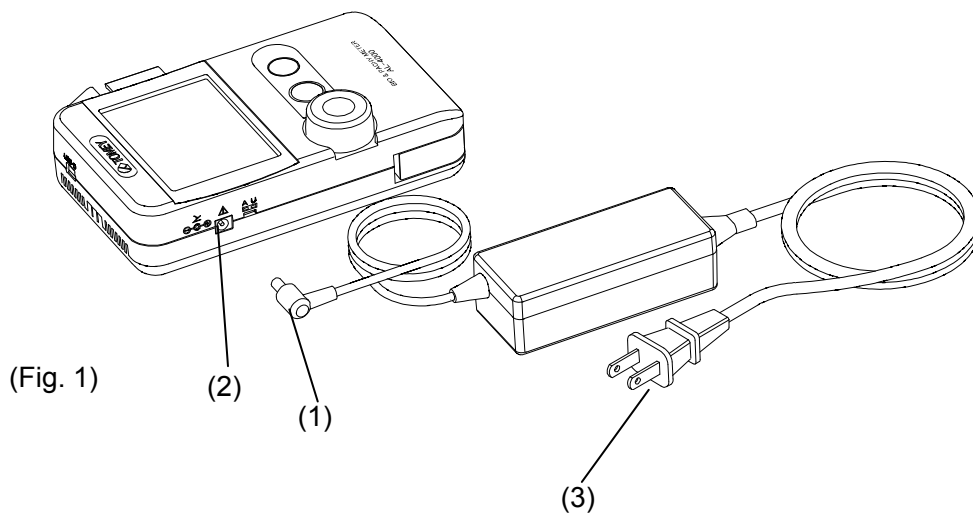

- 1) Insert the AC adapter connector (1) to the AC adapter/footswitch connector (2) on the side of the instrument.
- 2) Connect the plug (3) to the power outlet.

b) Replacing the probe holder

The probe holder (small) can be replaced with the probe holder (large) provided with the instrument. The probe holder (large) is for the biometry probe to which the probe sleeve is attached.

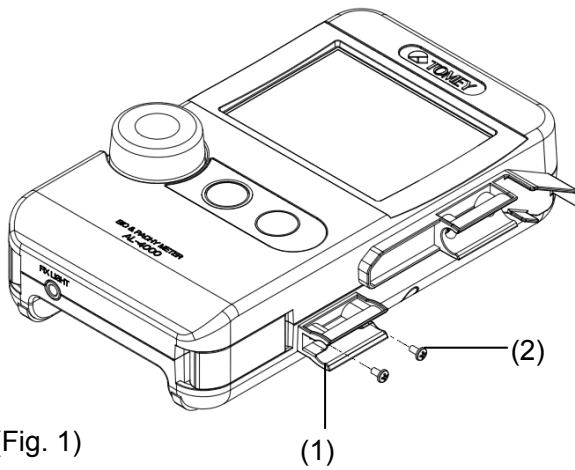

- 1) Remove the screws (2) that secure the probe holder (small) (1).

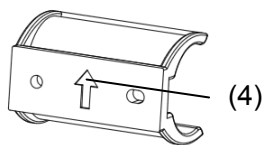
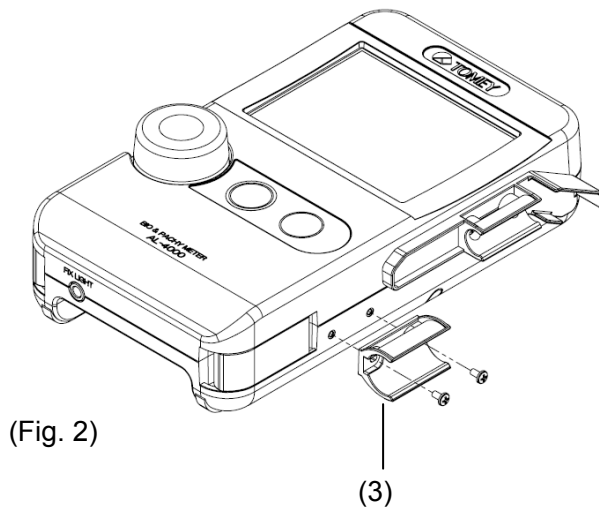

(Fig. 3)

- 2) Secure the probe holder (large) (3) on the side of the instrument with screws so that the arrow (4) on the back of the holder points upward (toward the LCD).

c) Connecting the biometry probe

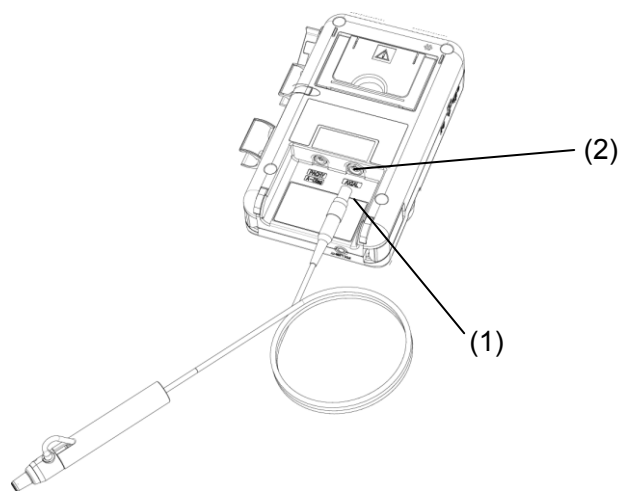

(Fig. 1)

Align the red marks and insert the connector of the biometry probe (1) to the biometry probe connector (2) at the bottom of the instrument until a click is heard.

d) Attaching the probe sleeve

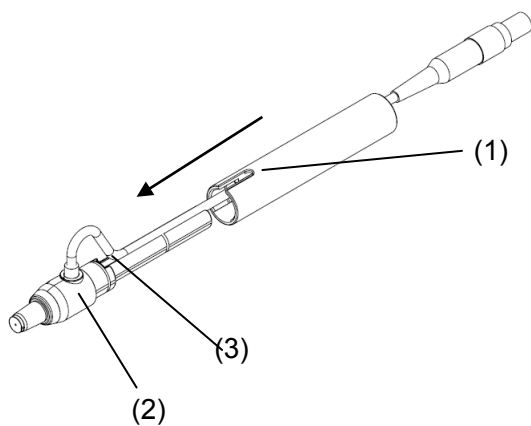

(Fig. 1)

- 1) Hold the probe sleeve so that the slit (1) is aligned with the probe and slide it to cover the biometry probe (2) from the connector side.
- 2) Align the slit of the probe sleeve with the groove of the biometry probe (3) and fully insert the probe into the sleeve.

e) Connecting the footswitch

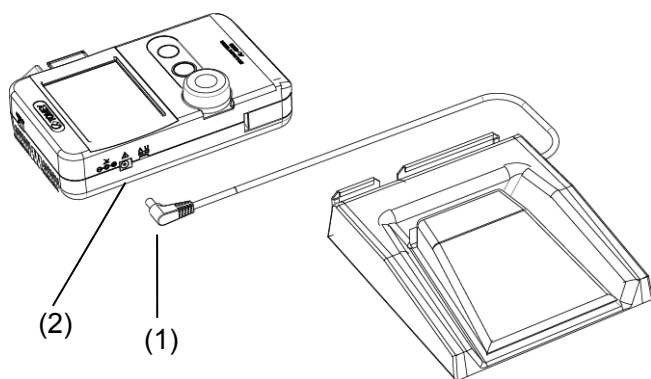

(Fig. 1)

- 1) Insert the footswitch connector (1) to the AC adapter/footswitch connector (2) on the side of the instrument.

[When using the AC adapter and footswitch together]

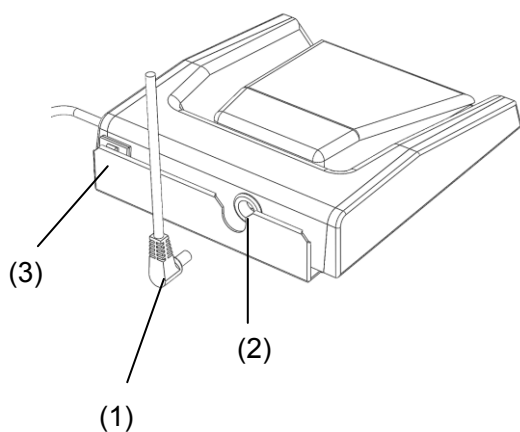

(Fig. 2)

- 2) Insert the connector of the AC adapter (1) to the AC adapter connector (2) of the footswitch.
- 3) Turn the connector counterclockwise and clamp the cable with the fixture (3) to fix it.

f) Connecting the corneal thickness/A-scan diagnosis probe

- Note** ■ *When using the pachymetry probe with a disposable tip, pay extreme attention not to allow air to enter the disposable tip. If air enters the tip, measurement cannot be performed or correct measurement cannot be obtained.*
- *When using the pachymetry probe with a disposable tip, press the “Calib (calibration)” button and calibrate the sensitivity of the probe after the disposable tip is replaced. Otherwise, measurement cannot be performed or correct measurement cannot be obtained.*

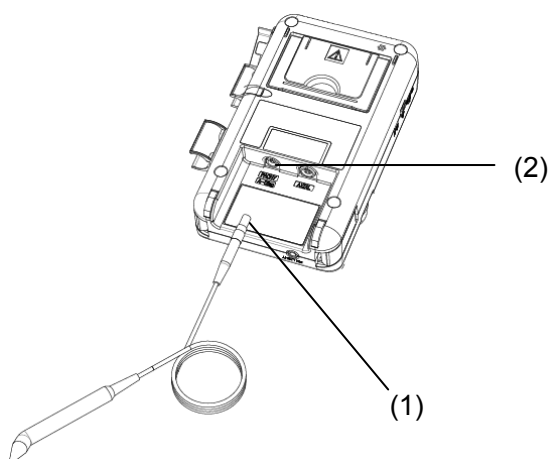

(Fig. 1)

- 1) Align the red marks and insert the connector of the corneal thickness/A-scan diagnosis probe (1) to the corneal thickness/A-scan diagnosis probe connector (2) at the bottom of the instrument until a click is heard.

g) Connecting UD-8000, IOL calculation unit, and personal computer

Note ■ *Check that either or both of the connected devices is in new patient mode before starting to communicate the patient information and measurement data. Communication cannot be started while both devices contain the information and measurement data of the last patient.*

This instrument can be connected to the UD-8000, IOL calculation unit, and personal computer.

Install the AL-4000 PC KIT (optional) software on the personal computer when connecting the instrument to the personal computer.

USB connection (wired) and wireless connection are available.

Direct connection (built-in connection) is also available to connected the UD-8000.

[Wire connection]

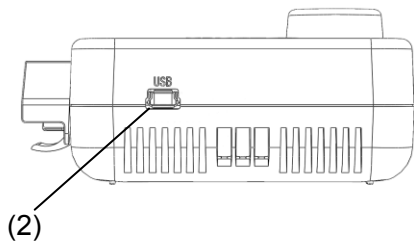

1) Insert the USB cable plug A (3) into the USB connector of the mating unit in the correct direction.

2) Insert the USB cable plug B (4) into the USB connector (2) on the top of the AL-4000.



[Wireless connection]

Complete settings according to “3.7.2 c) Wireless Communication Setting.”

[Built-in connection]

Directly connect the instrument to UD-8000.

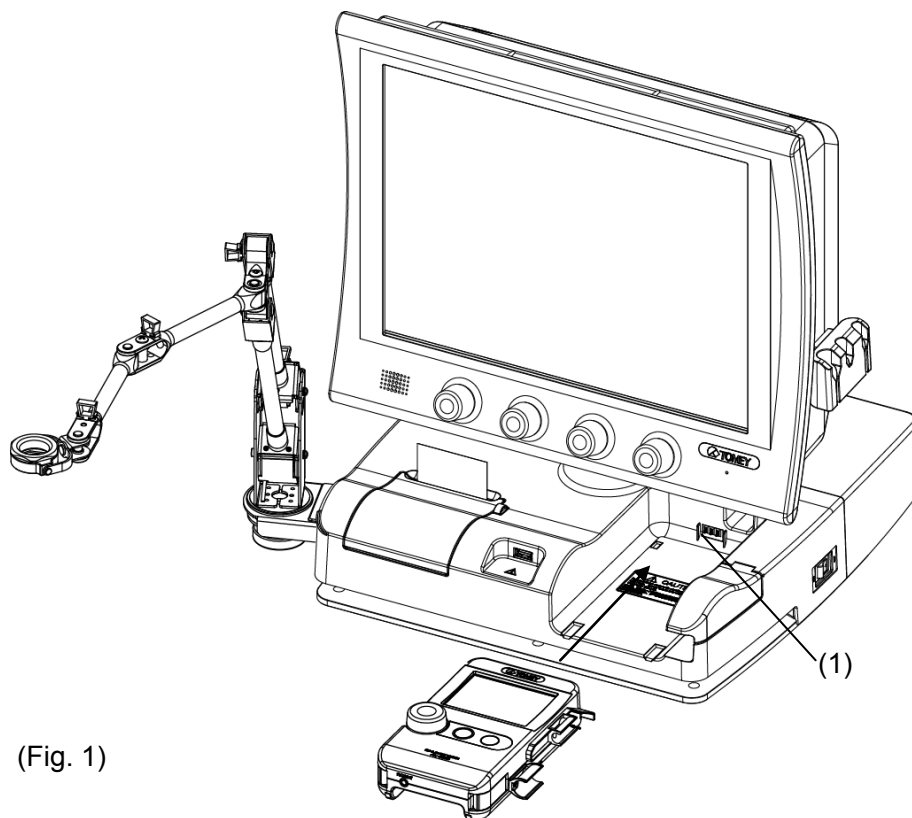

(Fig. 1)

Slowly push and slide the instrument to the back.

When the instrument is assembled in the UD-8000 main unit, power is supplied to the instrument via the UD-8000 power terminal (1).

Slowly pull out the instrument toward you to remove it.

The measurement data is communicated via wired connection or wireless connection. Refer to “Wired connection” and “Wireless connection” in this section for details.

3.2.2 Wireless connection with UD-8000 and IOL calculation unit



- *This equipment has been tested and found to comply with the limits for a Class B digital device, pursuant to Part 15 of the FCC Rules. These limits are designed to provide reasonable protection against harmful interference in a residential installation. This equipment generates, uses and can radiate radio frequency energy and, if not installed and used in accordance with the instructions, may cause harmful interference to radio communications. However, there is no guarantee that interference will not occur in a particular installation. If this equipment does cause harmful interference to radio or television reception, which can be determined by turning the equipment off and on, the user is encouraged to try to correct the interference by one or more of the following measures:*
- Reorient or relocate the receiving antenna.*
 - Increase the separation between the equipment and receiver.*
 - Connect the equipment to an outlet on a circuit different from that to which the receiver is connected.*
 - Consult the dealer or an experienced radio/TV technician for help.*

a) Wireless communication setting

Complete settings referring to “3.7.2 c) Wireless Communication Setting.”

b) Connection for wireless communication

- Note** ■ *Check that both or either of the connected devices is in new patient mode before starting to communicate the patient information and measurement data. Communication cannot be started while both devices maintain the information and measurement data of the last patient.*
- *When connecting a device with a USB cable during wireless communicating, wireless connection is changed to wired connection.*

[Automatic connection upon startup]

Wireless communication automatically starts with the first device that establishes a connection when this instrument is turned on. Refer to “3.7.2 c) Wireless Communication Setting” for how to set “automatic connection upon startup.” Refer to the instruction manual of each device for settings of the device.

[No communication state]

Note ■ *The confirmation screen appears when the data between the partner device and this instrument does not match.*

- 1) The confirmation screen appears if measurement data remains in the partner device when establishing a connection in new patient mode. (Fig. 1)
Click the “OK” button (1) to delete the data in the partner device and establish connection.
Click the “Cancel” button (2) to stop communication. (Fig. 2)



(Fig. 1) (1) (2)

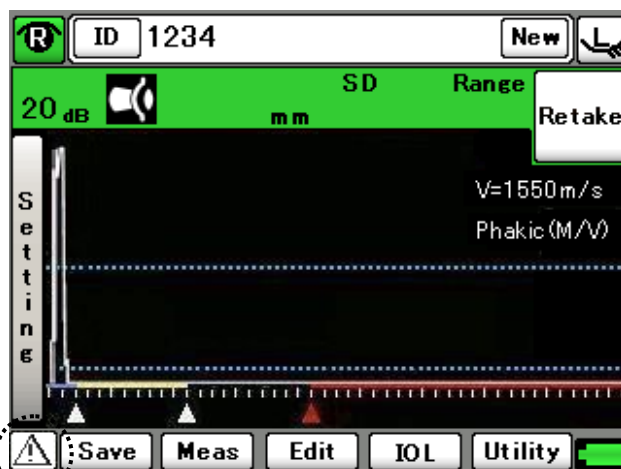

(Fig. 2)

[Resuming communication from the no communication state]

- 1) Click the “New” button of the partner device to clear the data in that device.

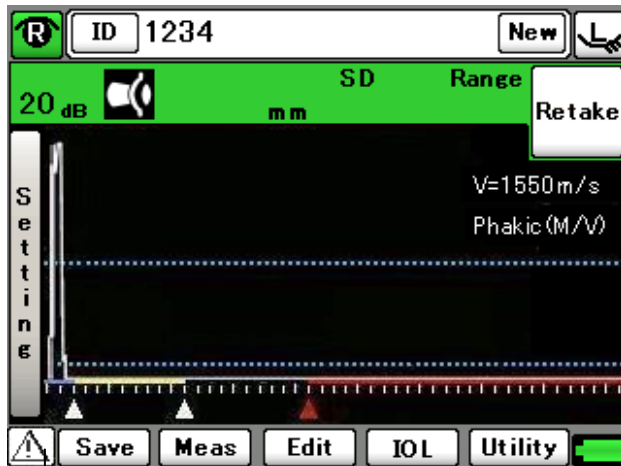

(Fig. 1)

(1)

- 2) Select the same measurement mode as that of the partner device in the “mode selection field.”
- 3) Click the “Communication check” button (1) to resume communication.

3.2.3 Turning the power on and adjustment after turning the power on

a) Turning the power on

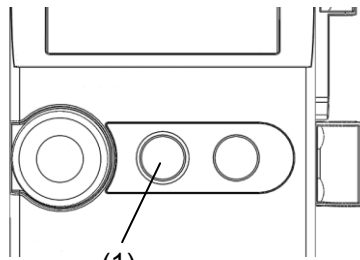

(Fig. 1)

- 1) Turn on the power switch (1) on the front of the main unit.

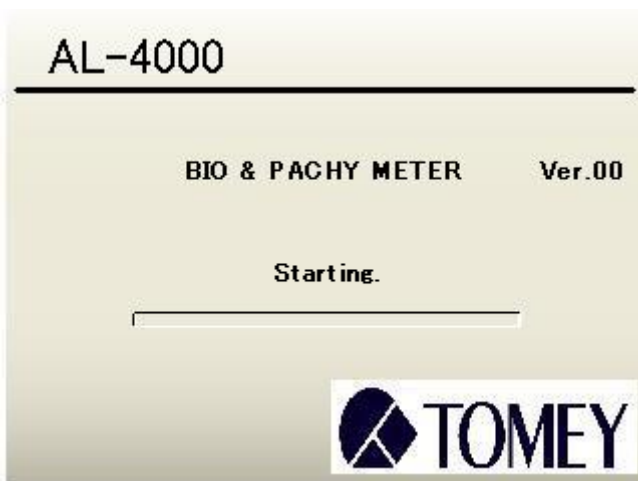

(Fig. 2)

- 2) The startup screen (Fig. 2) appears and allows you to make adjustments. When the pachymetry probe or A-scan diagnosis probe are connected together with the biometry probe, first priority is given to adjustments for the mode used when the power was last turned off.

Wireless communication starts only when the use of wireless communication is permitted and the device set in the utility is found.

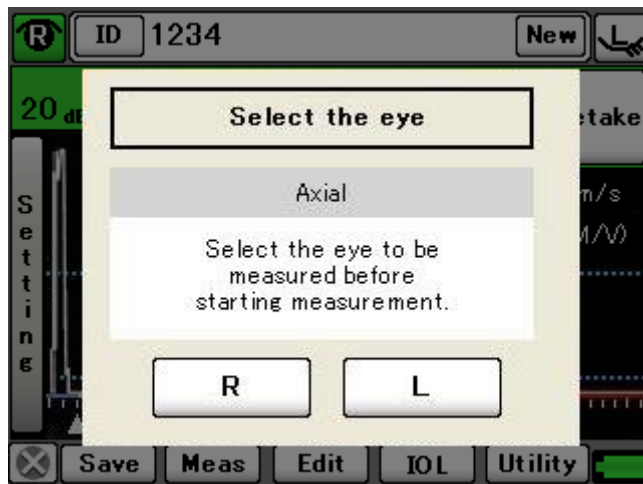

(Fig. 3)

- 3) The patient's eye selection screen (Fig. 3) appears when adjustments are completed correctly. When an eye is selected, the measurement screen for the current mode appears.

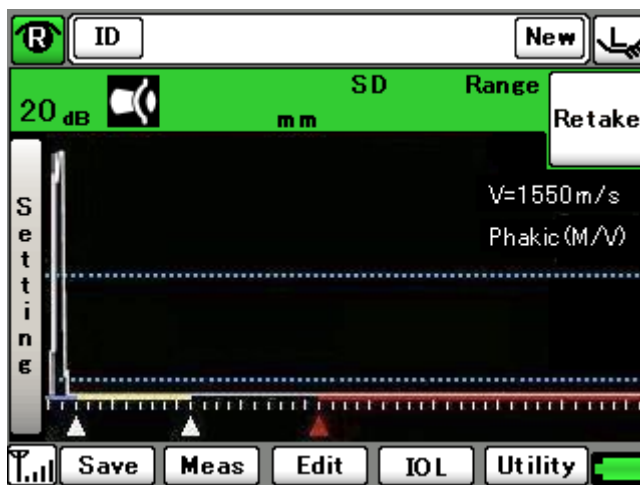

(Fig. 4)

b) Adjustment after turning power on

The brightness of the monitor can be adjusted according to the illumination in the examination room.

Also, the sound volume can be adjusted. (Refer to "3.7.2 a) Common Setting.")

3.2.4 Switching modes

Note ■ *When the mode is changed, all data captured in the previous measurement mode is deleted. Pay careful attention when changing the mode.*

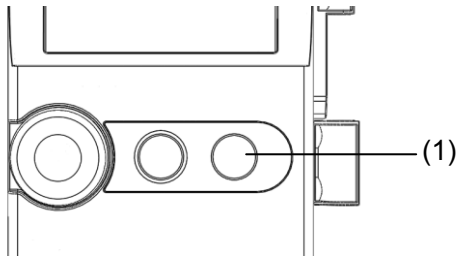

(Fig. 1)

- 1) Press the MODE button (1) on the front of the main unit for two seconds to change modes. Modes are changed from the biometry mode to pachymetry mode.

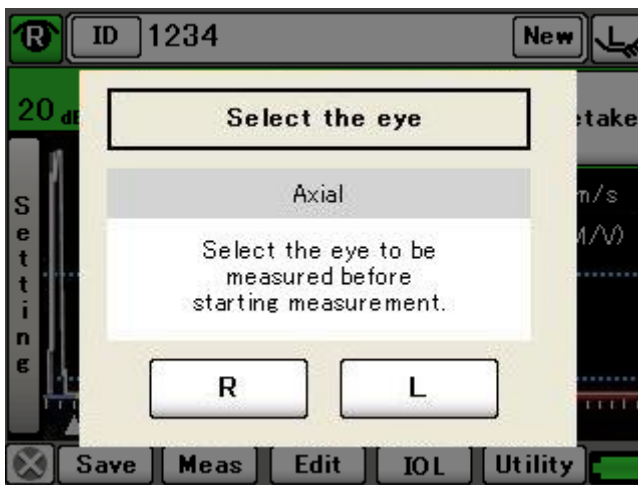

(Fig. 2)

- 2) When the mode is changed, the patient's eye selection screen (Fig. 2) appears. Select an eye and start new measurements.

3.2.5 Setting measurement conditions

Refer to “3.7 Utility” and set the measurement conditions.

3.2.6 Entering the patient data

Note ■ *If the patient information and measurement data already exists, make sure that both the new patient information and existing measurement data belong to the same patient before replacing the existing patient information with the new data.*

■ *The patient’s ID can be entered only when the patient information entry screen is displayed.*

■ *Also, entry of the patient’s ID is accepted only when this instrument is used independently.*

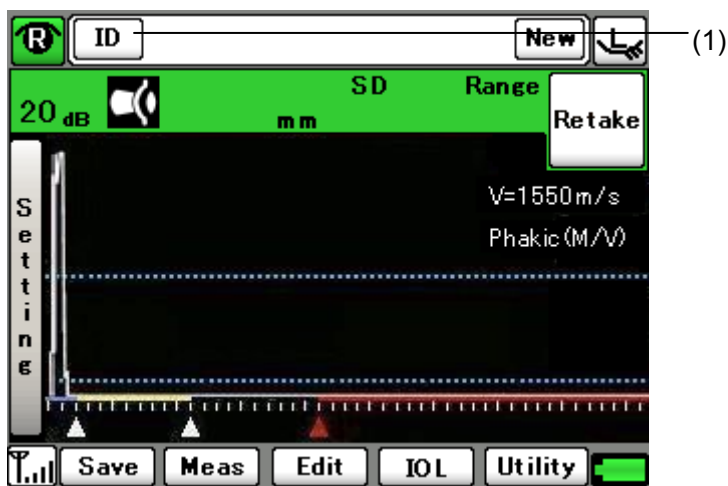

(Fig. 1)

- 1) Touch the “ID” button in the upper left of the measurement screen in each mode to open the patient information entry screen (Fig. 2).

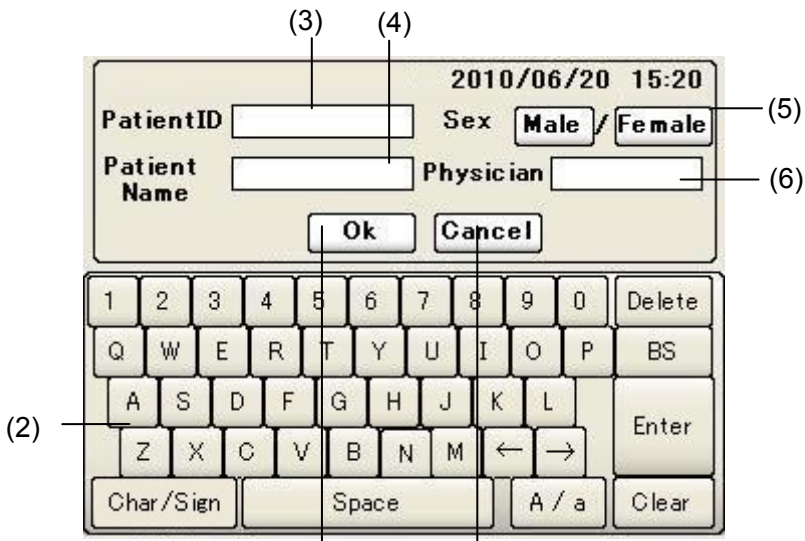

(Fig. 2)

(7) (8)

- 2) Enter the ID (3) and name (4) using the software keyboard (2). Periods (.) and spaces are not acceptable for the ID number.
- 3) Touch “Male” button or “Female” button to set the gender (5).
- 4) Enter the patient’s name (6) using the software keyboard (2).
- 5) After all data is entered, touch the “OK” button (7) to set the entered data and return to the previous screen (Fig. 1). Touch the “Cancel” button to ignore the entered data and return to the previous screen (Fig. 1).
- 6) If an ID number is entered while the patient information and measurement data already exist, the confirmation screen (Fig. 3) appears.

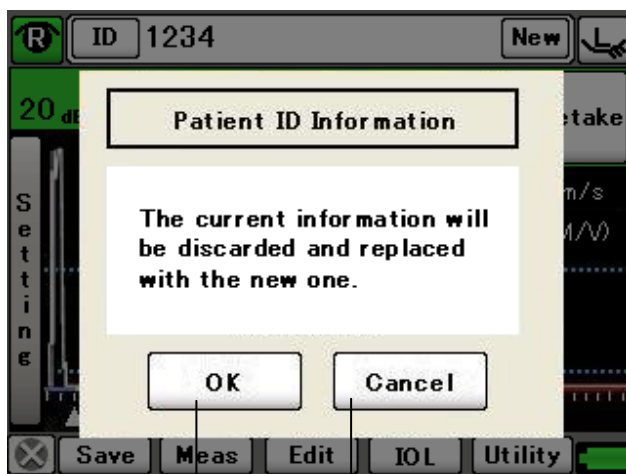

(Fig. 3)

(9) (10)

-
- 7) Touch the “OK” button (9) to retain the measurement data, overwrite the existing patient information with the newly entered data, and return to the previous screen (Fig. 1).
Touch the “Cancel” button (10) to ignore the entered data and return to the previous screen (Fig. 1).

3.2.7 Clear all measurement data (preparation for measuring a new patient)

- Note** ■ *The deleted data cannot be restored. Carefully check the data before deleting it.*
- *Be sure to touch the “New” button to delete all the measurement data for the previous patient before measuring another patient. If the data of the next patient is captured without touching the “New” button, the patient information will not match the captured data.*
- *The “New” button is effective only when this instrument is used independently.*

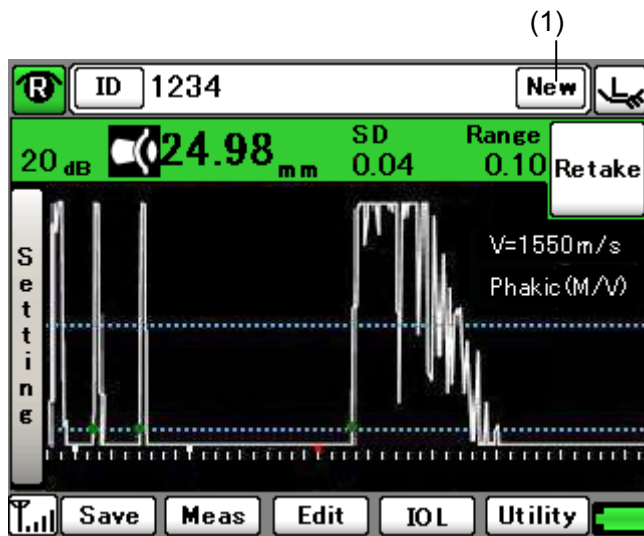

(Fig. 1)

When the “New” button (1) in the upper right of the screen in each mode is held for approximately 1 second until a beep sounds, the patient information (ID, name, and sex) and measurement data is all deleted and the measurement screen for a new patient appears.

3.2.8 Selecting the eye to be measured

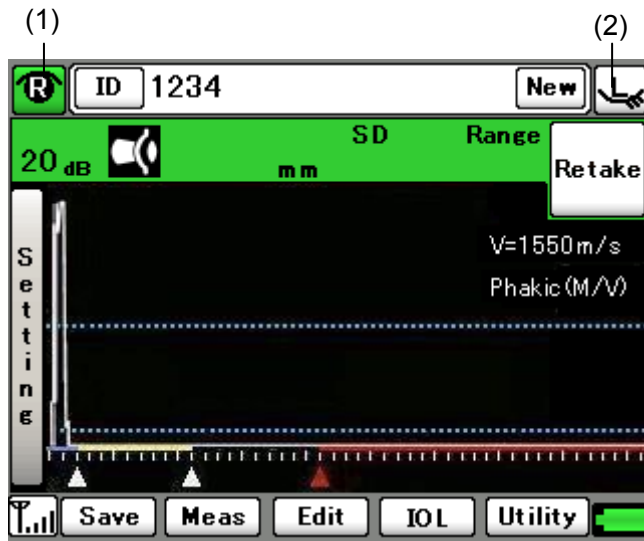

(Fig. 1)

Touch either the “R (right)” (1) or “L (left)” (2) eye display button.

3.3 Axial length measurement function

3.3.1 Connecting the biometry probe

Connect the biometry probe to the instrument. Refer to “3.2.1 c) Connecting the biometry probe.”

3.3.2 Setting axial length calculation method and converted acoustic velocity for eye to be measured

Note ■ *Settings made here are only effective for the eye currently selected. Settings cannot be made for both eyes simultaneously. Complete necessary settings for each eye.*

Select the eye to be measured from the following 4 options according to the patient's eye.

Select the material of the implanted IOL in the case of an eye with IOL.

■ Phakic eye

Select this for a normal eye or when the crystalline lens nucleus is comparatively soft, such as an eye in the initial stage of cataracts.

■ Dense cataract eye

Select this when the crystalline lens nucleus is comparatively hard, such as an eye with dense cataracts, and when it is difficult to take measurements in the mode for an eye with initial stage cataracts using an echo reflected from the back of the crystal lens.

■ Aphakic eye

Select this in the case of aphakic eyes.

IOL eye: Acrylic / Silicone / PMMA / user

Select this when an IOL is implanted in the patient's eye.

“Anterior chamber depth” and “lens” are not measured for an aphakic eye and “lens” is not measured for an IOL eye.

The instrument may not recognize waveforms on the back of the crystal lens due to multiechoes in the crystal lens in an eye with dense cataracts.

Eye to be measured	Axial length	Anterior chamber depth	Lens
Phakic eye (Average acoustic velocity, divisional acoustic velocity)	○	○	○
Dense cataract eye	○	○	△
Aphakic eye	○	*	*
IOL eye (All materials)	○	○	*

○: Measurements are displayed.

△: Measurements may not be displayed.

*: Measurements are not displayed

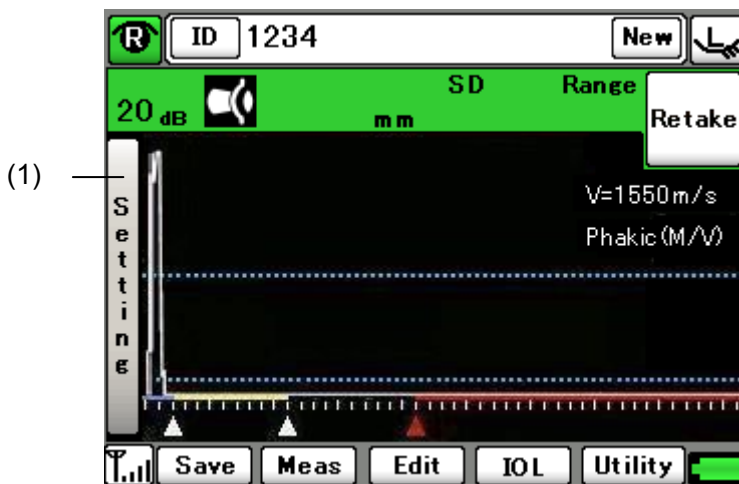

(Fig. 1)

1) Touch the “Setting” button (1) to open the setting screen (Fig. 2).

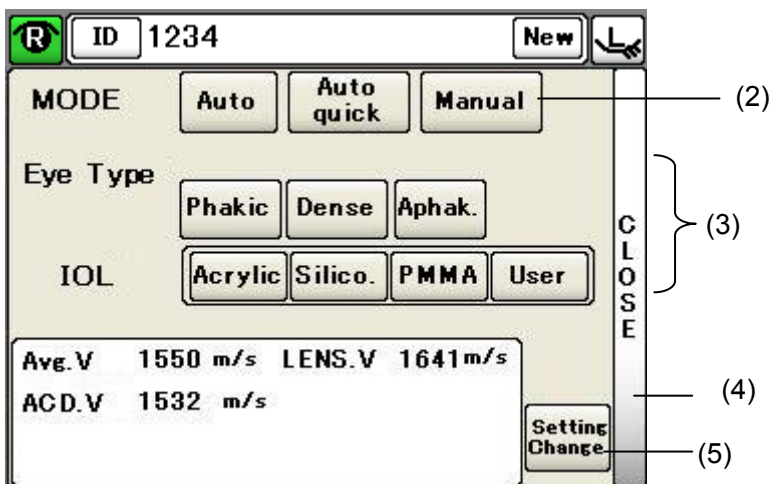

(Fig. 2)

- 2) Touch one of the "MODE" buttons (2) to select the measurement mode.
 - Auto
Select this for normal measurements.
 - Auto quick
Select this when measurement is difficult.
 - Manual
Select this when measurement is difficult in Auto and Auto quick modes.
- 3) Touch any of the "Eye Type" buttons (3) to set the eye to be measured.
- 4) Touch the "CLOSE" button (4) to return to the capturing screen (Fig. 1) when the converted acoustic velocity is not changed. Touch the "Change Setting" button (5) to open the change setting screen (Fig. 3) to change the converted sonic velocity.
- 5) Similarly, edit the setting in the change setting screen (Fig. 3) to change the IOL materials. However, only the "User" can be changed.

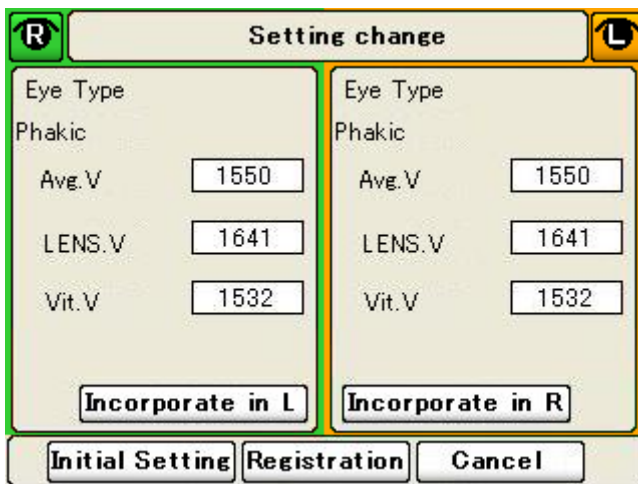

(Fig. 3)

- 6) Entry boxes for the acoustic velocities required for the measurement conditions currently set appear. Enter the converted acoustic velocity for the corresponding eye type using the keypad (6) that appears when the entry box is touched.

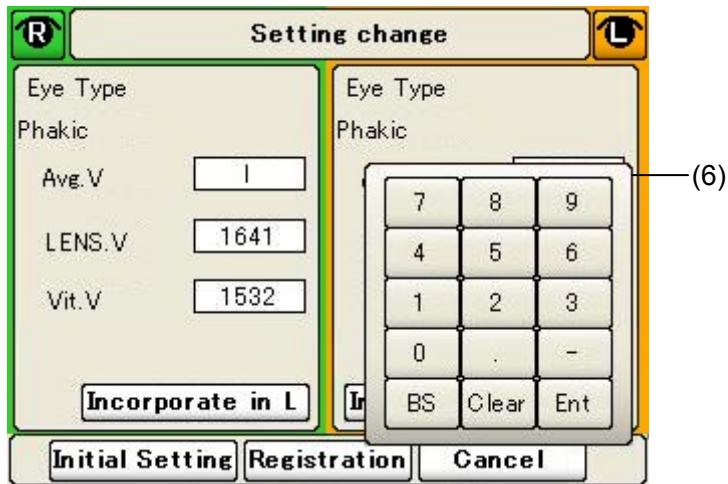

(Fig. 4)

- 7) Touch the “Ent (enter)” key to apply the setting and proceed to the next entry box.

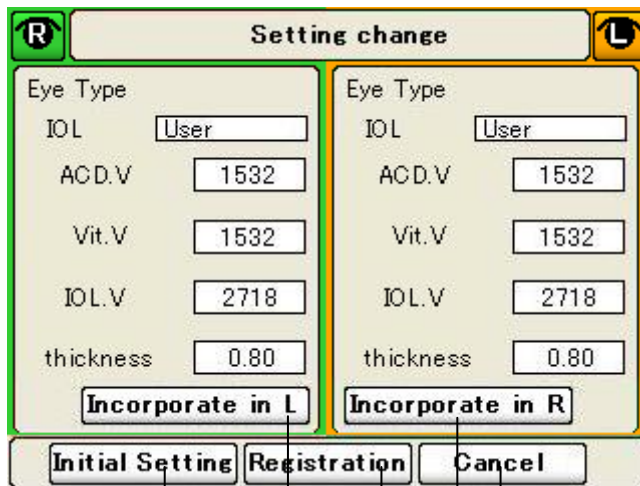

(Fig. 5)

(9) (7) (10) (8) (11)

- 8) Touch the “Incorporate in L” button (7) or “Incorporate in R” button (8) to apply the data entered for one eye to the other eye. Touch the “Initial Setting” button (9) to enter the initial settings.

(Initial setting and setting range of converted acoustic velocity)

■ Phakic eye

Average acoustic velocity for axial length	: 1,550 m/s, 1,500 - 1,600 m/s
Crystal lens acoustic velocity	: 1,641 m/s, 1,540 - 1,740 m/s
Anterior chamber depth acoustic velocity	: 1,532 m/s, 1,430 - 1,630 m/s
Vitreous acoustic velocity (divisional velocity only)	: 1,532 m/s, 800 - 2,000 m/s

■ Dense cataract eye

Average acoustic velocity for axial length	: 1,548 m/s, 1,500 - 1,600 m/s
Crystal lens acoustic velocity	: 1,629 m/s, 1,540 - 1,740 m/s
Anterior chamber depth acoustic velocity	: 1,532 m/s, 1,430 - 1,630 m/s

■ Aphakic eye

Average acoustic velocity for axial length	: 1,532 m/s, 1,430 - 1,630 m/s
--	--------------------------------

■ IOL eye

Implanted lens acoustic velocity	(Acrylic)	: 2,200 m/s, 800 - 3,000 m/s
	(Silicone)	: 1,049 m/s, 800 - 3,000 m/s
	(PMMA)	: 2,718 m/s, 800 - 3,000 m/s
Anterior chamber depth acoustic velocity		: 1,532 m/s, 1,430 - 1,630 m/s
Vitreous acoustic velocity		: 1,532 m/s, 800 - 2,000 m/s
IOL thickness	(Acrylic)	: 0.80 mm, 0.10 - 4.00 mm
	(Silicone)	: 1.00 mm, 0.10 - 4.00 mm
	(PMMA)	: 0.80 mm, 0.10 - 4.00 mm

- 9) Touch the "Registration" button (10) to apply the entered settings and close the setting change screen.
- 10) Touch the "Cancel" button (11) to ignore the entered settings and close the setting change screen.

3.3.3 Contact/immersion mode settings

Complete the settings for contact mode and immersion mode referring to “3.7.2 d) Eye Axis Setting.”

3.3.4 Operation check

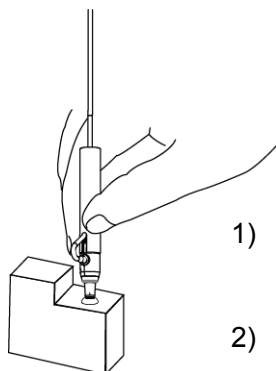

(Fig. 1)

Note ■ *This biometry test piece cannot measure or calibrate the accuracy of the instrument.*

- 1) The biometry test piece provided with the instrument allows you to check the operation of the instrument.
- 2) Select “Aphakic eye” for the eye type to be measured.
- 3) Wet the surface of the test piece and set the biometry probe perpendicular to the surface to start measurement.

3.3.5 Preparation for measurement

Note ■ *Cooperation by the patient is required to perform measurement smoothly. Explain the measurement method to the patient before starting measurement to help them relax.*

- 1) Check the measurement condition settings and operation as needed.
- 2) Apply topical anesthesia for the eye and, in chin-rest measurement mode, adjust the height of the chair, optical table, and chin rest.
- 3) For measurement in manual mode, have the patient sit down on the chair or lie on their back so that they are in a comfortable position while measurement is performed.
- 4) When the other eye needs to be guided with the fix light in chin-rest measurement mode, place the lamp on the chin rest in front of the other eye.

3.3.6 Precautions for measurement

a) Handling the biometry probe in contact/immersion modes

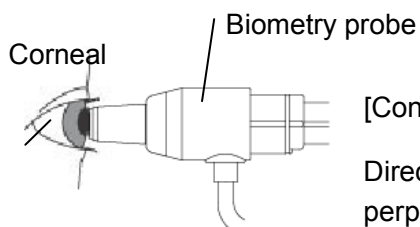

[Contact mode]

Directly apply the contact section of the biometry probe perpendicularly to the center of the corneal.

(Fig. 1)

[Immersion mode]

The biometry probe can be used while its tip is immersed in ultrasound media (water, corneal protective agent, etc.).

■ When the immersion attachment is not used

- 1) Apply the biometry probe perpendicularly to the corneal center where ultrasound media is applied.
- 2) Apply an ultrasound media such as corneal protective agent between the contact section of the biometry probe and corneal so that the gap between the corneal and contact section of the probe is always approximately 2.0 – 5.0 mm.

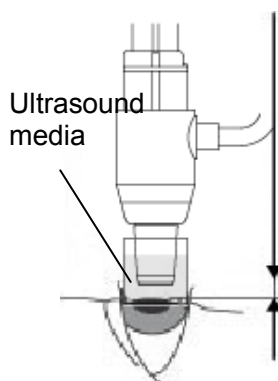

Approximately 2.0 - 5.0 mm

(Fig. 2)

■ When the immersion attachment is used

Note ■ *When putting the ultrasound media in the cup at the tip of the immersion attachment, pay extreme attention not to allow air to enter the cup. If air is in the cup, measurement cannot be performed or correct measurement cannot be obtained.*

■ *When using the immersion attachment, be very careful not to allow the tip to contact the corneal. The corneal may be damaged or the axial length is measured shorter due to pressure.*

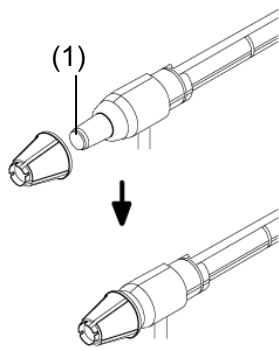

(Fig. 3)

Lightly apply the ultrasound media to the contact section (1) of the biometry probe and cover the probe with the immersion attachment. (Fig. 3)

Put the ultrasound media in the cup at the tip of the immersion attachment until it rises slightly. (Fig. 4)

Set the tip of the immersion attachment perpendicular to the center of the corneal, referring to the biometry probe axis and visual axis. The appropriate position is so that the tip of the immersion attachment does not come in contact with the corneal. (Fig. 5)

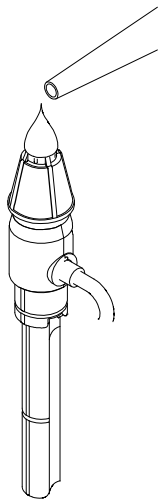

(Fig. 4)

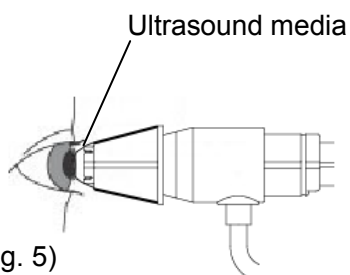

(Fig. 5)

b) Handling the slider in chin-rest measurement mode

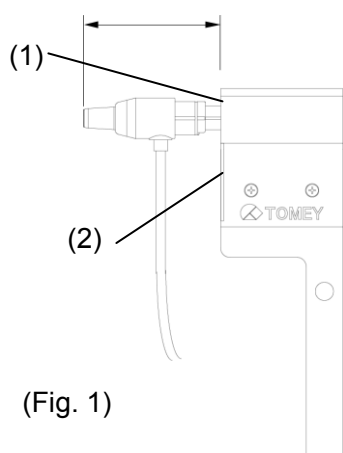

(Fig. 1)

- 1) Attach the biometry probe. When the cord length from the biometry probe to the cord hook is insufficient, the corneal may experience pressure.
- 2) Firmly press the biometry probe so that the surface of the moving section (1) of the slider is almost flush with the surface of the fixed section (2) as shown in the illustration when performing measurement. When the probe is not pressed firmly, the axial length may be measured longer due to corneal protective agent or tears. However, if the probe is pressed too far beyond this position, the corneal may experience pressure. Do not press the probe excessively.

c) Attaching the biometry probe to the applanation tonometer

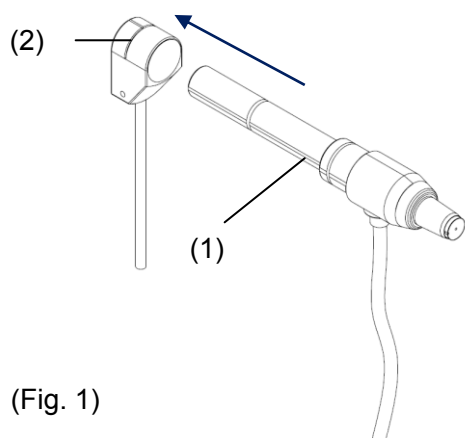

(Fig. 1)

- 1) Insert the biometry probe (1) to the prism attachment section (2) of the applanation tonometer from the patient's side.
- 2) Set the measurement knob of the applanation tonometer to the following positions to prevent pressure on the corneal.
 - 10 mmHg when the intraocular pressure of the eye is 20 mmHg or lower
 - 10 mmHg lower than the intraocular pressure when the intraocular pressure of the eye is 20 mmHg or higher

d) Selecting the retina waveform

Note ■ *Settings made here are only effective for the eye currently selected. Settings cannot be made for both eyes simultaneously. Complete necessary settings for each eye.*

Set the retina gate cursor to the left of the retina waveform when there is a waveform between the waveform on the back of the crystal lens and retina waveform and the instrument cannot recognize the original retina waveform. The instrument recognizes a waveform on the right of the retina gate cursor as the retina waveform and conducts measurement.

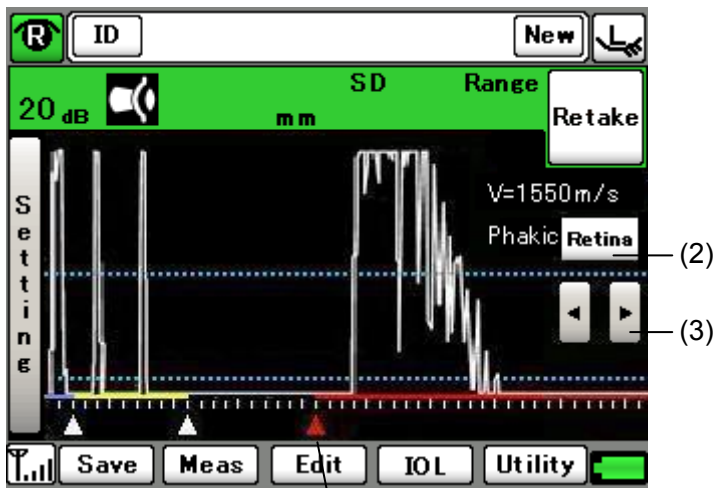

(Fig. 1)

- 1) Check that the retina gate cursor (1) is active. If not, touch the "Retina" button (2) to switch the active gate cursor.
- 2) Touch the gate cursor movement buttons (3) to move the retina gate cursor (1) to the left of the retina waveform. (Fig. 2)

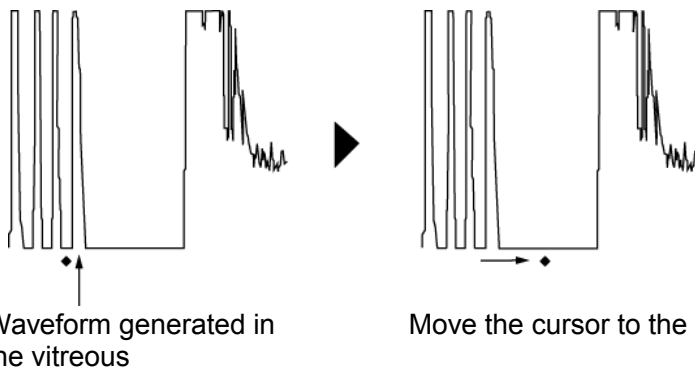

(Fig. 2)

e) Selecting the waveform on the back of the lens

Note ■ *Settings made here are only effective for the eye currently selected. Settings cannot be made for both eyes simultaneously. Complete necessary settings for each eye.*

Set the gate cursor for the back of the lens to the right of the waveform on the back of the lens when there are multiple waveforms in the crystal lens and the instrument cannot recognize the original waveform on the back of the lens.

The instrument recognizes a waveform on the left of the gate cursor for the back of the lens as the waveform on the back of the lens and conducts measurement. The gate cursor on the back of the lens can be set only when the eye type is set to “Phakic eye” or “Dense cataract.”

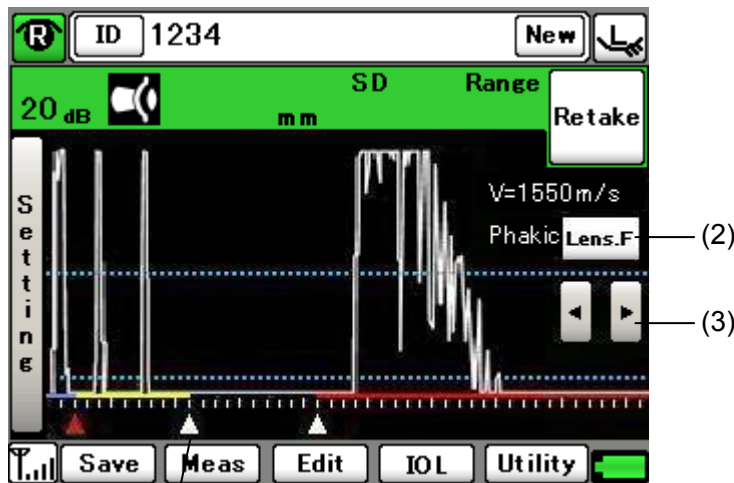

(Fig. 1) (1)

- 1) Check that the gate cursor for the back of the lens (1) is active. If not, touch the “Lens. R” button (2) to switch the active gate cursor.
- 2) Touch the gate cursor movement buttons (3) to move the gate cursor for the back of the lens (1) to the right of the waveform on the back of the lens. (Fig. 2)

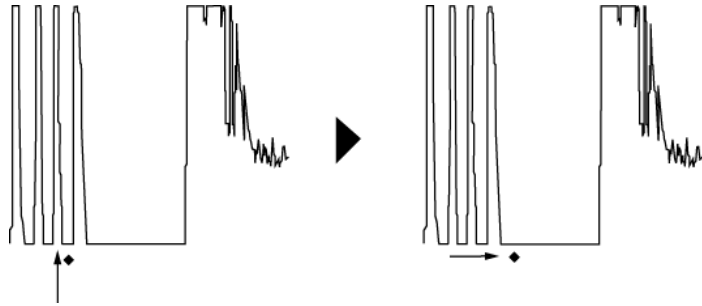

Waveform generated in the crystal lens

Move the cursor to the right of the waveform of the back of the lens.

(Fig. 2)

f) What is a good waveform?

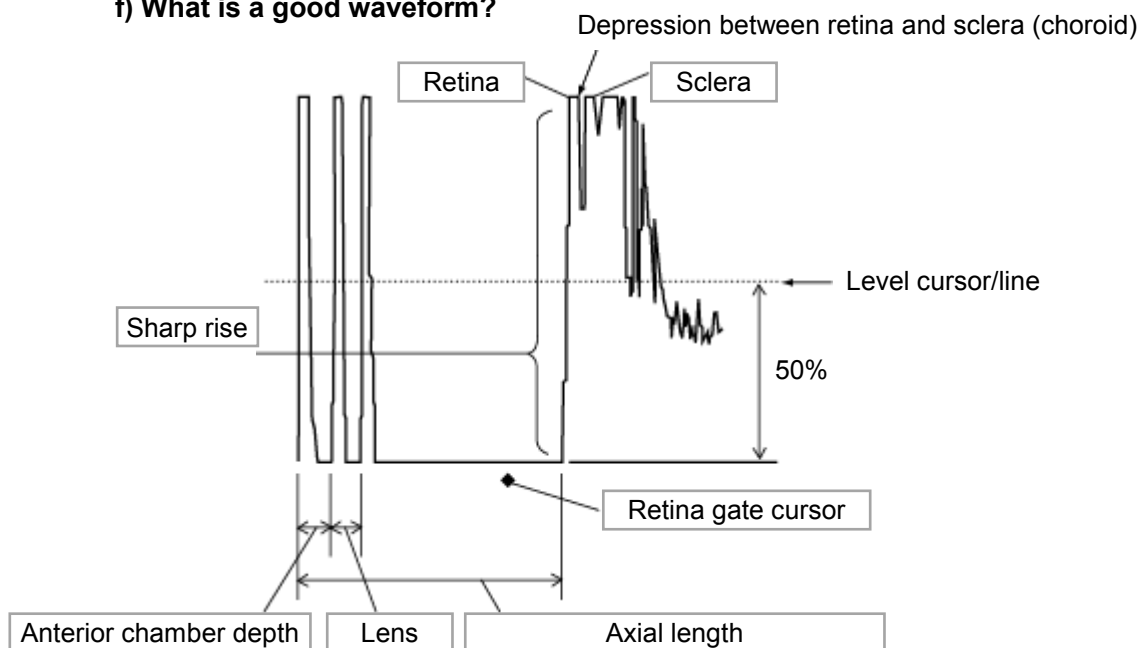

(Fig. 1)

[Contact mode]

The instrument recognizes a waveform as a good one if conditions 1) to 3) listed below are satisfied and captures the measurement data in auto measurement mode.

- 1) Each of the following waveforms rises above the level cursor/line position.
 - Eye with initial stage cataracts
Waveform on the front of crystal lens / Waveform on the back of crystal lens / Retina waveform
 - Dense cataract eye
Waveform on the front of crystal lens / Retina waveform
 - Aphakic eye
Retina waveform
 - IOL eye
Waveform on the front of crystal lens / Retina waveform
- 2) The retina waveform rises vertically. (Ultrasound wave reaches the retina perpendicularly.)

When the waveform slopes upward, the measurement tends to be long.

3) Within the measurement range

The following is not a requirement for capturing the measurement data, but a method to confirm that the ultrasound wave correctly captures the geometrical axis and ideal waveforms are taken.

- i. When the retina waveform spikes, the ultrasound wave reaches the retina perpendicularly.
- ii. When the waveforms on the front/back of the crystal lens spike, the ultrasound wave correctly captures the geometrical axis.
- iii. When the retina waveform can be distinguished from the sclera waveform, the ultrasound wave reaches the retina perpendicularly. Because the depression between two waveforms (choroid) cannot be confirmed when the gain is set high, etc., these waveforms may not need to be distinguished from each other.
- iv. When there is no tailing that follows the initial waveform (corneal waveform), the biometry probe directly comes in contact with the retina. When there is a layer of tears or corneal protective agent between the probe and corneal, tailing occurs after the corneal waveform. In this case, the measurement data may be unstable or tends to be longer.

[Immersion mode]

The following conditions are added to conditions (1) to (3) in contact mode for automatic measurement in immersion mode.

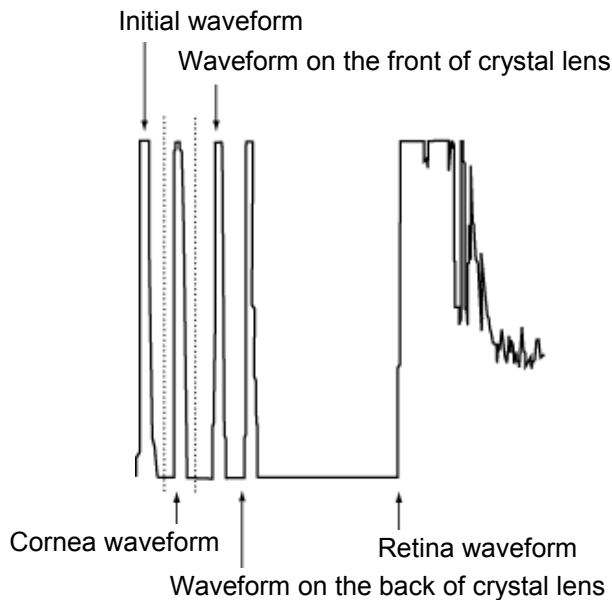

(Fig. 2)

- 4) The corneal waveform is formed within 2.0 – 5.0 mm from the initial waveform.
(Range between the dotted lines in the illustration)

The following is not a requirement for capturing the measurement data, but a method to confirm that ideal waveforms are taken. Check the following together with items i – iv in contact mode.

- v. There are no unnecessary waveforms between the initial waveform and corneal waveform. An unnecessary waveform appears when air bubbles are contained in the ultrasound media in the cup at the tip of the immersion attachment or the media placed between the biometry probe and corneal.

3.3.7 Measurement



- *Sterilize the biometry probe before use.*
- *Do not use the biometry probe with its contact section damaged. Measurement error may occur, and the corneal may be injured.*
- *Immersion attachment is a disposable part. Do not reuse it. Otherwise, you may contract diseases.*



- *The converted acoustic velocity directly affects the measurement data. Check that the desired value is set before starting measurement.*
- *Check the settings in contact mode and immersion mode before starting measurement. In immersion mode, apply an ultrasound media such as corneal protective agent so that the clearance between the corneal and the contact section of the biometry probe is approximately 2.0 – 5.0 mm.*
- *Be very careful not to apply pressure to the corneal when taking measurement. In chin-rest measurement mode, be very careful not to apply pressure to the corneal by moving the slider beyond the allowable range. Also, do not apply too much corneal protective agent if used. The measurement data may be affected.*
- *The automatic measurement function is an auxiliary function to take measurements more easily. This is not a function for making actual clinical judgments.*
- *Be sure to touch the “New” button to delete all the measurement data of the previous patient before measuring another patient. If new measurement is started without deleting the previous data, the measurement data of the previous patient may be included.*

a) Automatic measurement (Auto / Auto quick)

[Auto]

A waveform that satisfies the conditions is captured and its values are displayed. Up to 10 values are displayed and measurement is completed when variations are within a specific value.

[Auto quick]

A waveform that satisfies the conditions is captured and its values are displayed. Up to 10 values are displayed and measurement is completed when variations are within a specific value. (The conditions are different to those for Auto mode.)

- 1) The instrument automatically starts capturing when a waveform satisfies the conditions. When the measurement data is captured, a beep sounds.
- 2) At least 20 data sets are captured and measurement is completed when variations are within a specific value. The waveform displayed at this time is the measurement data closest to the average value.

b) Manual measurement

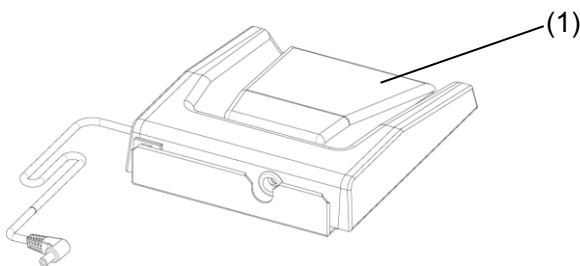

(Fig. 1)

- 1) The instrument beeps when the capturing conditions are satisfied.
- 2) Press the footswitch (1) to capture the measurement data.
- 3) Press the footswitch (1) again to start the next measurement.
- 4) Repeat measurements in the same manner. When 10 sets of measurement data are taken, a beep sounds again and measurement is completed.

c) Re-measurement of the same patient

- Note** ■ *The deleted data cannot be restored. Carefully check the data before deleting it.*
- *Be sure to touch the “New” button to delete all the measurement data of the previous patient before measuring another patient. If the data of the next patient is captured without touching the “New” button, the patient information does not match the captured data.*

Retain the patient information and delete only the measurement data for each eye. Delete all data referring to “3.2.7 Clear all measurement data (preparation for measuring a new patient)” when the patient is changed.

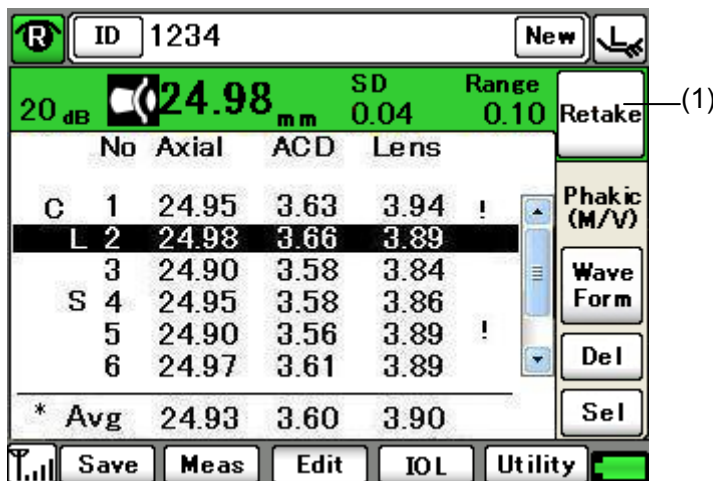

(Fig. 1)

The data of only one eye is deleted.
 Hold the “Retake” button (1) for approximately 1 second until a beep sounds to delete the data.
 The patient information is not deleted.

d) Gain setting

Note ■ *Settings made here are only effective for the eye currently selected. Settings cannot be made for both eyes simultaneously. Complete necessary settings for each eye.*

Adjust the waveform height according to the gain settings. The gain and the waveform height increase as the gain value increases.

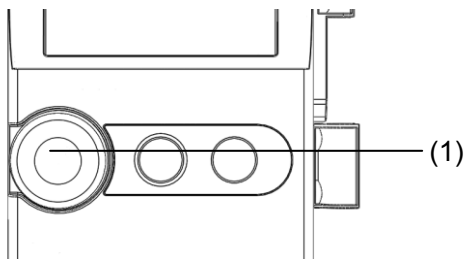

(Fig. 1)

- 1) Turn the gain adjustment knob (1) to set the gain. The setting is shown in the gain display field (2) on the monitor.

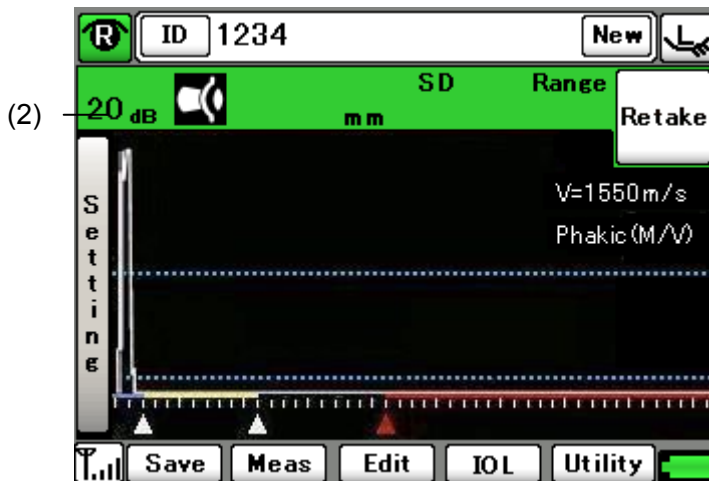

(Fig. 2)

e) Setting the gate cursor

Note ■ *Settings made here are only effective for the eye currently selected. Settings cannot be made for both eyes simultaneously. Complete necessary settings for each eye.*

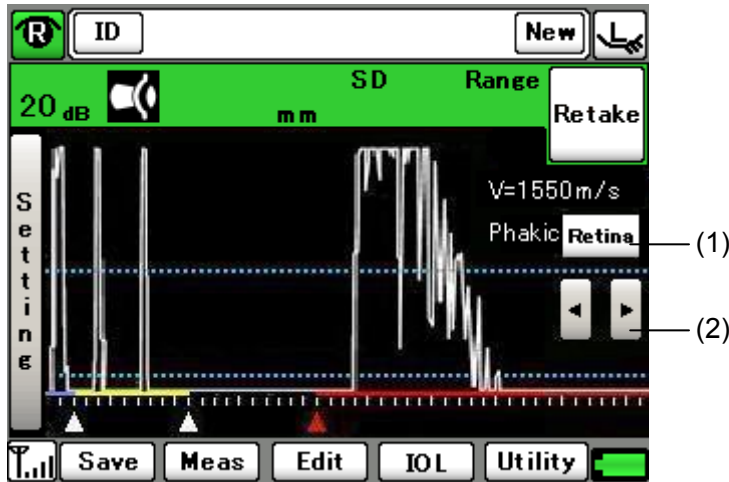

(Fig. 1)

- 1) Check that the gate cursor to be adjusted is active. The active gate cursor is displayed in red and the other cursors in white. When the cursor is not active, touch the “Retina” button (1) to switch the active gate cursor. The “Retina” button appears for 5 seconds when the gate cursor is touched.
- 2) Touch the gate cursor movement buttons (2) to set the gate cursor position.

3.3.8 Checking waveforms after measurement

a) Displaying the optional waveform data

An optional waveform can be recalled from the measurement data and checked.

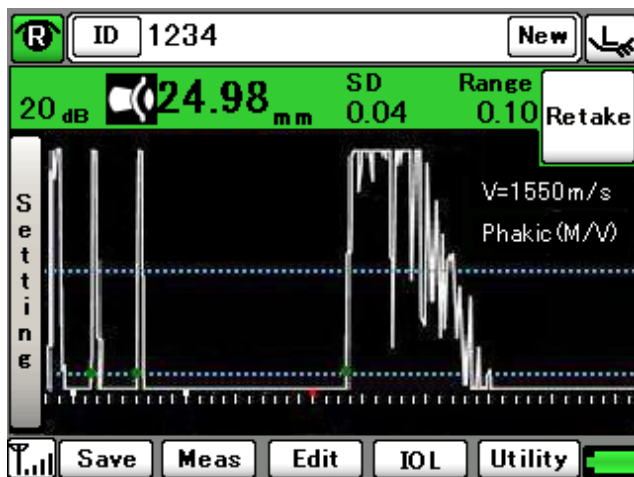

(Fig. 1)

(1)

- 1) Touch the "Edit" button (1) when all necessary measurement data is captured or during measurement to open the measurement data check screen. (Fig. 2)

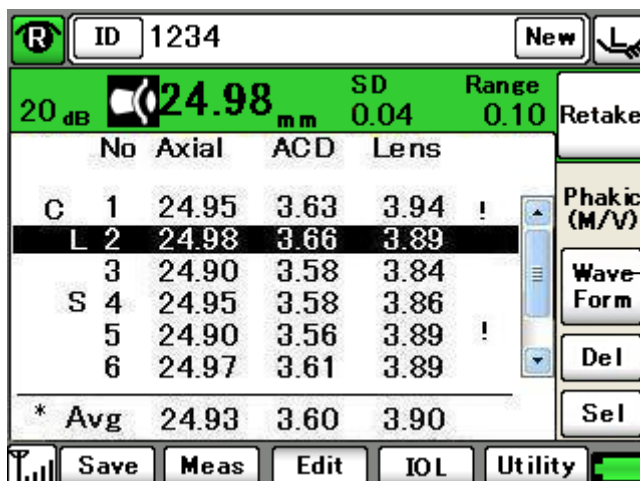

(Fig. 2)

- 2) Directly touch the measurement data to select it and touch the "Wave Form" button (2). The waveform of the selected measurement data appears. (Fig. 3)

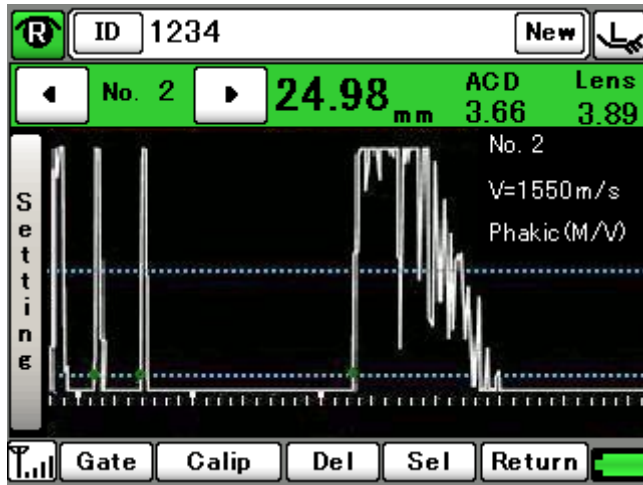

(Fig. 3)

b) Selecting specific axial length data to be used for calculating IOL power

The average value is normally adopted for the measurement data to be saved or used for calculating the IOL power, but specific data can also be selected.

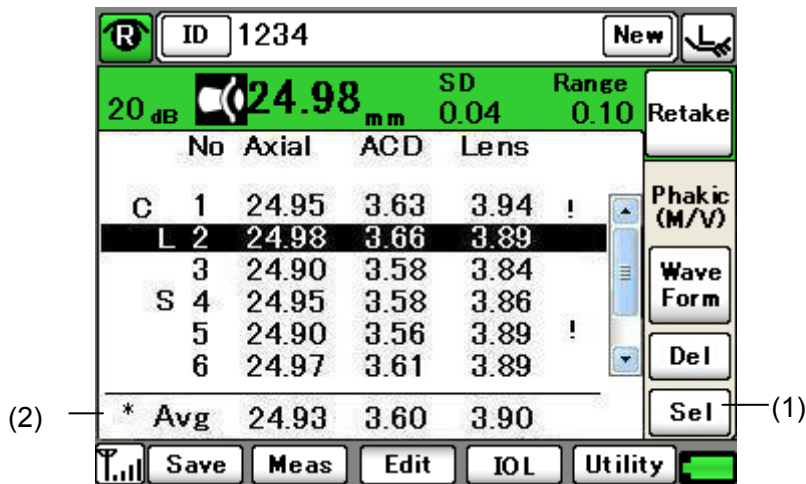

(Fig. 1)

- 1) Highlight the specific data on the edit screen.
- 2) Touch the “Sel (select)” button (1) to select the data used for calculating the IOL power. An asterisk “*” (2) moves to the left of the selected data.
- 3) To use the average value for IOL power calculation, highlight the average axial length data at the bottom and touch the “Sel” button (1).

c) Deleting part of measurement data

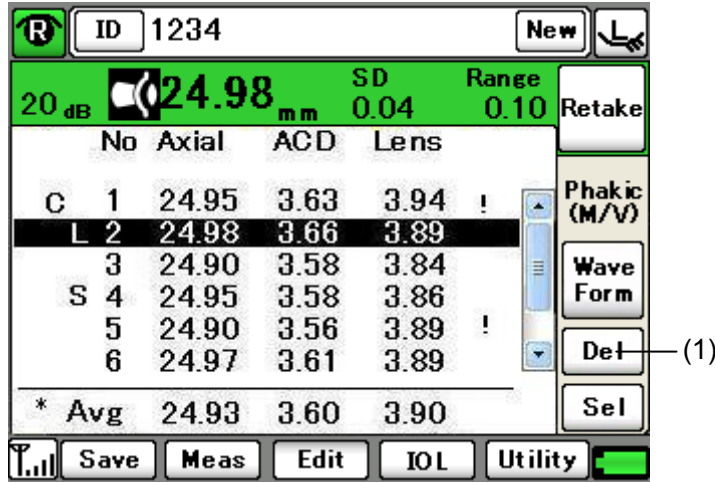

(Fig. 1)

- 1) Highlight the specific data on the edit screen.
- 2) When the “Del” button (1) is touched to delete the data, the button indication changes to “Ret.” (Fig. 2)

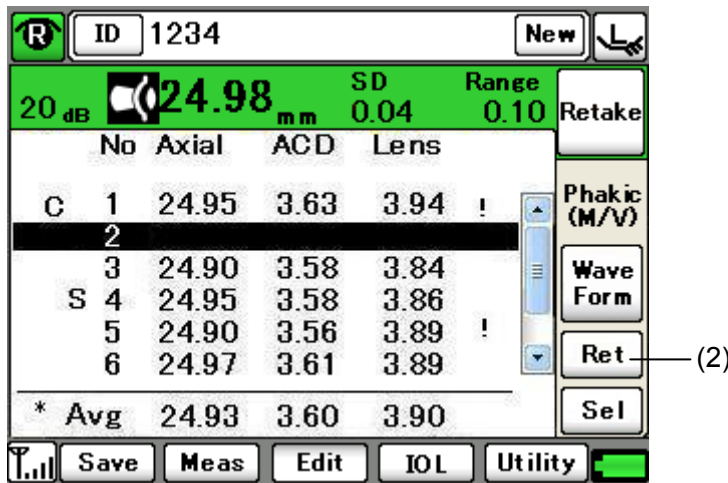

(Fig. 2)

- 3) When data is deleted by mistake or to cancel deletion of data, touch the “Ret” button (2) to restore the data. However, once the screen returns to the measurement screen, the deleted data cannot be restored by the “Ret” button even when the screen is switched to the edit screen again.

d) Gate change function

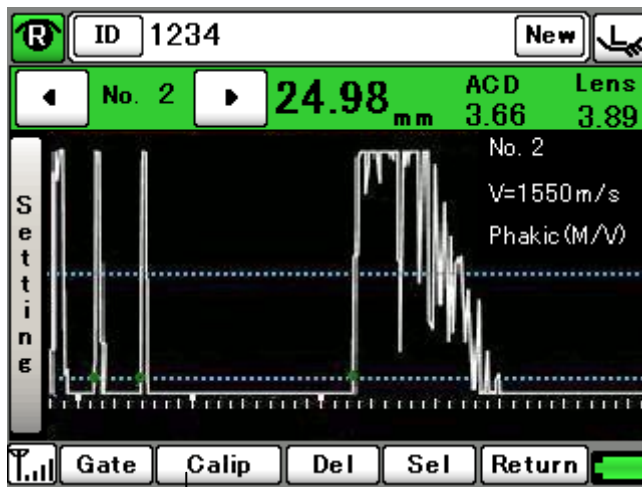

(Fig. 1)

(1)

- 1) Touch the "Gate" button (1) on the edit (waveform display) screen to open the gate change screen. (Fig. 2)

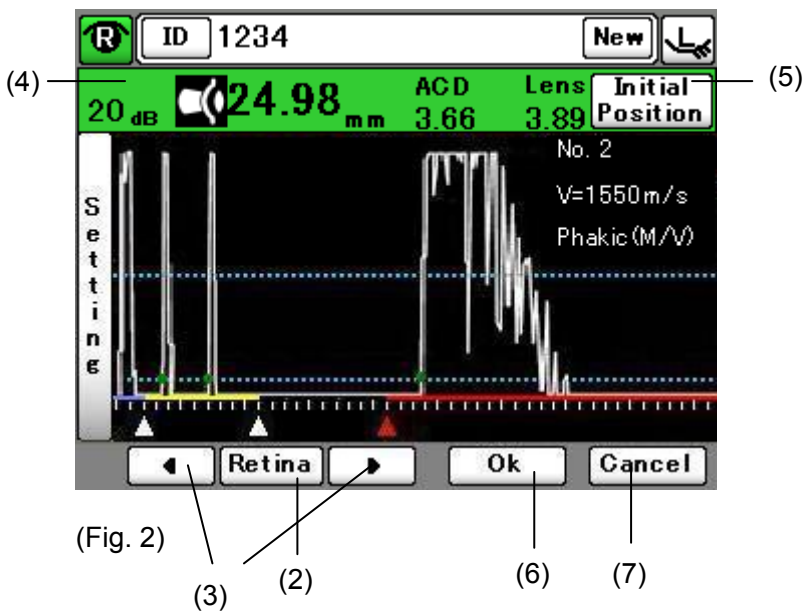

(Fig. 2)

(3)

(2)

(6)

(7)

- 2) Check that the gate cursor to be adjusted is active. When the cursor is not active, touch the "Retina" button (2) to switch the active gate cursor.
- 3) Touch the gate cursor movement buttons (3) to set the gate cursor position.

-
- 4) The changed measurement data is displayed in the edit data display field (4) along with the movement of the gate cursor. When the gate cursor position is changed by mistake, touch the “Initial Position” button (5) to return the gate cursor to the original position.
 - 5) Touch the “OK” button (6) to apply the edited contents and return to the previous screen (Fig. 1). Touch the “Cancel” button (7) to ignore the edited contents and return to the previous screen (Fig. 1).

e) Caliper function

Note ■ Values measured and displayed using the caliper function are rough estimates and may differ from the actual measurement result.

This function is used to measure the distance at an arbitrary section of the measurement waveform. Dotted caliper lines appear and the distance between these lines is displayed. Three caliper lines are shown in contact mode and four lines in immersion mode. One caliper line is displayed in red (active caliper) and the other lines in yellow.

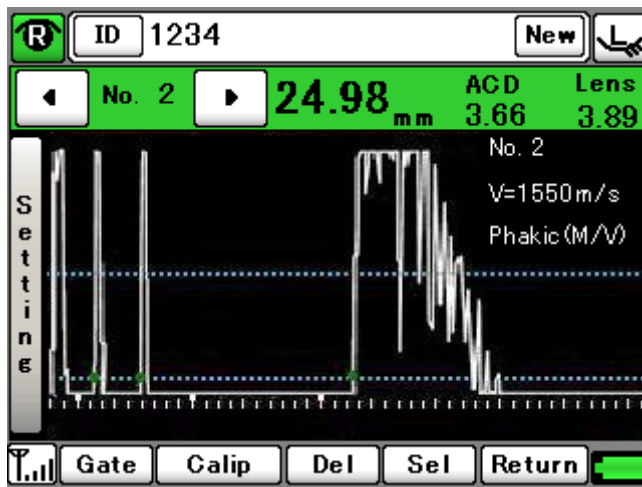

(Fig. 1)

(1)

- 1) Touch the “Calip” button (1) on the edit screen (waveform display) to open the caliper screen. (Fig. 2)

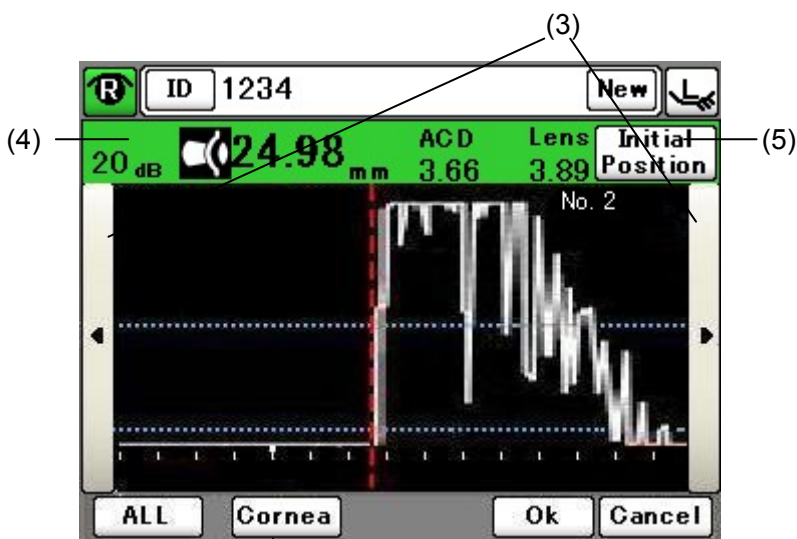

(Fig. 2)

(6)

(2)

- 2) An enlarged waveform centered around the active caliper line is displayed. Check that the caliper line to be adjusted is active. If not, touch the “Cornea” button (2) to switch the active caliper line.
- 3) Touch the caliper line movement buttons (3) to change the caliper line position. The changed measurement data is displayed in the edit data display field (4) along with the movement of the caliper line. When the line position is changed by mistake, touch the “Initial Position” button (5) to return the caliper line to the previous position.
- 4) Touch the “ALL” button (6) to display the waveforms in normal magnification. (Fig. 3)

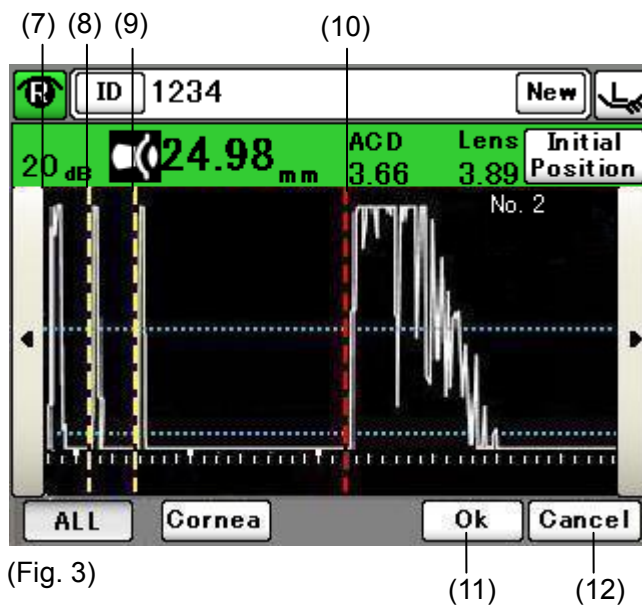

(Fig. 3)

- 5) The distance between the start line (7) and the retina caliper line (10) is shown in the axial length field, that between the start line (7) and the caliper line for the front of the crystal lens (8) is shown in the ACD (anterior chamber depth) field, and that between the caliper lines for the front of the crystal lens (8) and for the back of the crystal lens (9) is shown in the Lens field.
- 6) Touch the “OK” button (11) to apply the edited contents and return to the previous screen (Fig. 1). Touch the “Cancel” button (12) to ignore the edited contents and return to the previous screen (Fig. 1).

3.4 IOL power calculation

3.4.1 Calculation

- Note** ■ *When using the result of axial length for calculation of the IOL power, the physician must examine the measurement result.*
- *Calculation by this instrument may cause some errors due to the number of significant digits in internal calculations.*
- *Complex numbers may be generated for the SRK/T formula. In this case, the “√ section” is calculated as zero and an asterisk “*” is shown on the right of the calculation result.*

This instrument automatically calculates the IOL and displays the result when all necessary items described in “3.4.2 Setting calculation conditions” and “3.4.3 Entering calculation parameters” are set.

3.4.2 Setting calculation conditions

Refer to “3.2.8 Selecting the eye to be measured.”

3.4.3 Entering calculation parameters

a) Axial length and anterior chamber depth

- Note** ■ *The anterior chamber depth is displayed only when “HAIGIS standard formula” is selected.*

When measurement has already been completed, the axial length and anterior chamber depth are automatically entered and cannot be entered manually. (Refer to “3.3.8 b Selecting specific axial length data to be used for calculating IOL power.”) When measurement has not yet been performed, enter the data as follows.

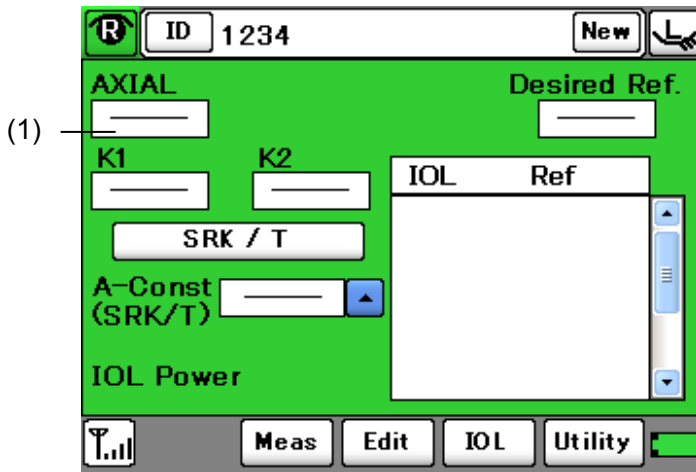

(Fig. 1)

- 1) Touch the AXIAL input field (1) to activate it. The keypad (2) appears. (Fig. 2)

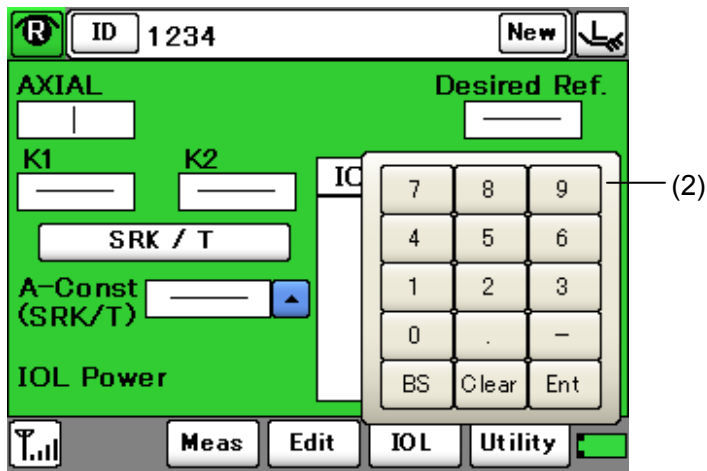

(Fig. 2)

- 2) Enter the data using the keypad (2).
[Acceptable range]
Axial length: 13.00 - 45.00 mm
- 3) Touch the "Ent (enter)" key to apply the data

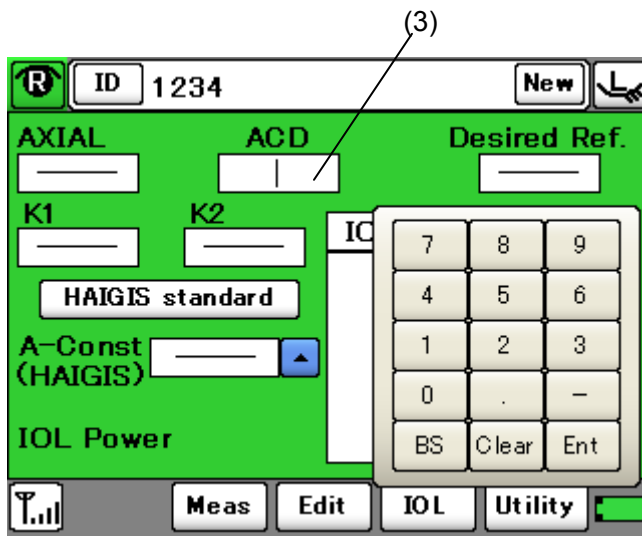

(Fig. 3)

- 4) When HAIGIS standard is selected, the ACD field (3) also appears. Enter the appropriate value in the same manner.

[Acceptable range]
ACD : 0.00 - 10.00 mm

b) Corneal refractive power and radius of corneal curvature (K1/K2)

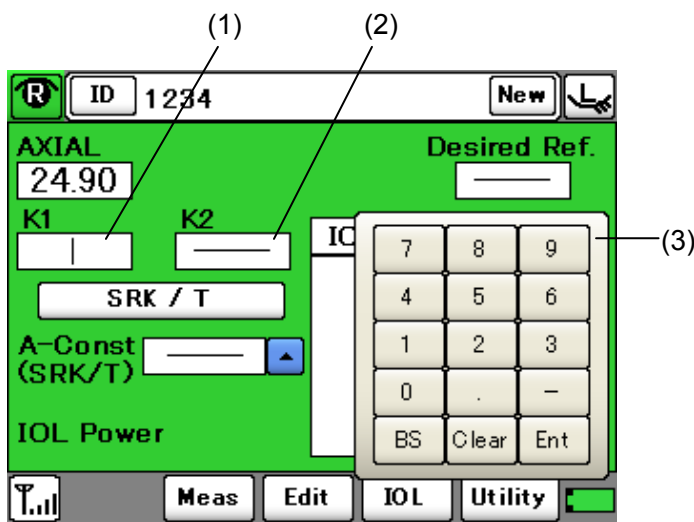

(Fig. 1)

- 1) Touch the K1 input field (1) or K2 input field (2) to activate it. The keypad (3) appears.

- 2) Enter the data using the keypad (3).
[Acceptable range]
Corneal refractive power: 30.00 D - 60.00 D
Radius of corneal curvature: 5.00 - 11.00 mm
- 3) Touch the “Ent (enter)” key to apply the data.

c) Desired refractive power

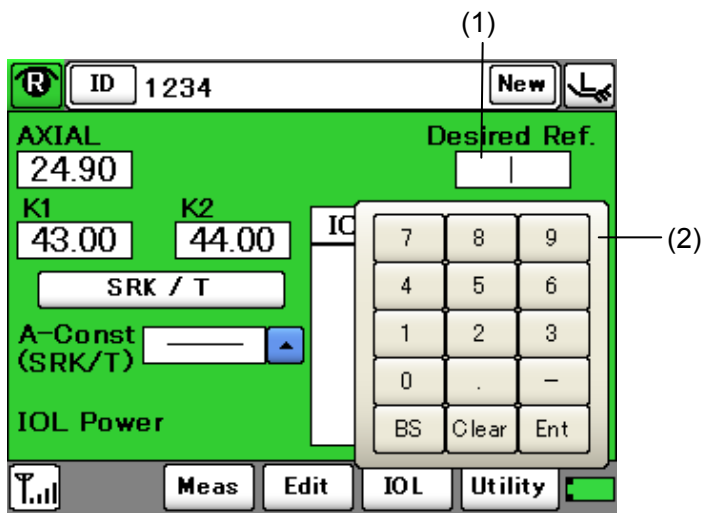

(Fig. 1)

- 1) Touch the Desired Ref. input field (1) to activate it. The keypad (2) appears.

Enter the data using the keypad (2).
[Acceptable range]
-30.00 D - +10.00 D
- 2) Touch the “Ent (enter)” key to apply the data.

The entered value is stored in the main unit, and is not cleared even when the power is turned off.

d) Lens constants (A-constant/SF/ACD-constant/ACD constant)

Enter lens constants for IOL according to the formula. This instrument is able to internally save up to 5 constants for 1 formula for the right and left eyes as input history. There are 2 ways to enter values. One is to enter it directly using the keypad, and the other is by selecting it from the list.

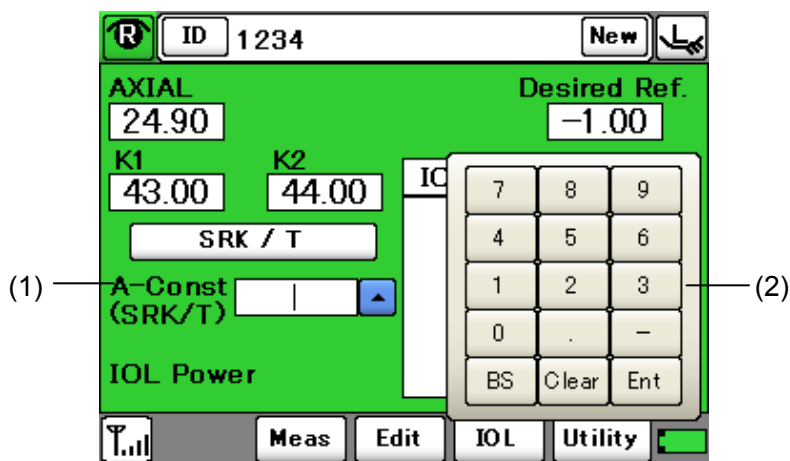

(Fig. 1)

● Entering using keypad:

- 1) Touch the A-Const field (1) to activate it. The keypad (2) appears.
- 2) Enter the data using the keypad (2).

[Acceptable range]

A-constant : 100.00 - 130.00

ACD-constant : 0.00 - +10.00

SF :-5.00 - +10.00

- 3) Touch the "Ent (enter)" key to apply the data.

● Selecting from the list:

The last 5 constants entered are saved in the instrument and these can be selected from the list.

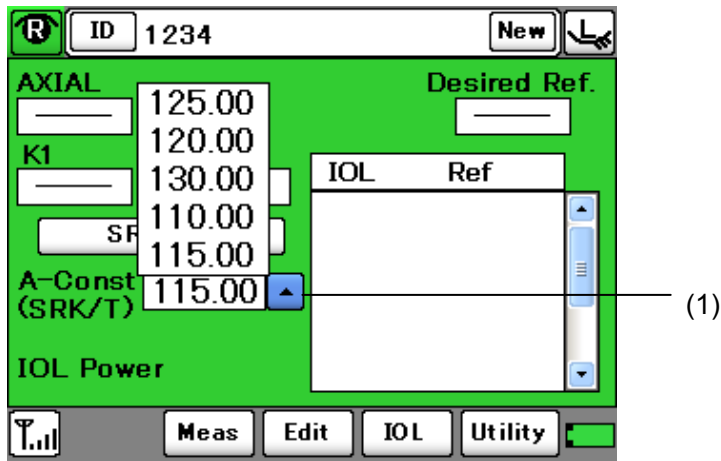

(Fig. 1)

- 1) Touch the arrow button (1) on the right of the A-Const input field. The list appears.
- 2) Touch the desired constant to select it. The list closes and the selected value is defined.

3.4.4 Setting calculation formula

Select the calculation formula from the following 5 options.

- SRK-II
- SRK/T
- HOLLADAY
- Hoffer Q
- HAIGIS standard

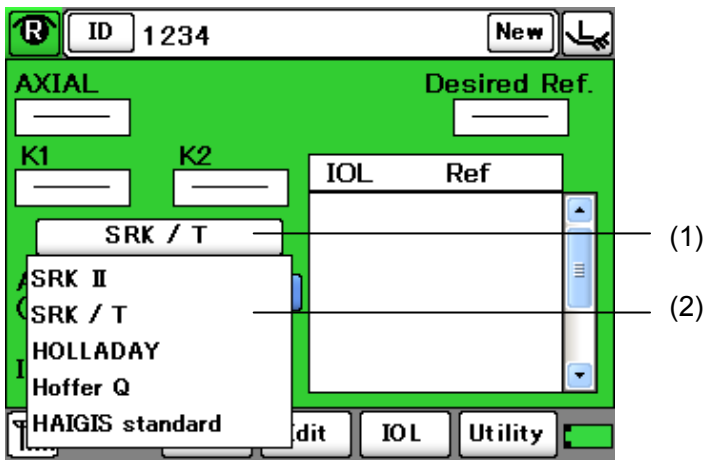

(Fig. 1)

- 1) Holding the formula selection button (1) for approximately 1 second displays the formula list (2).

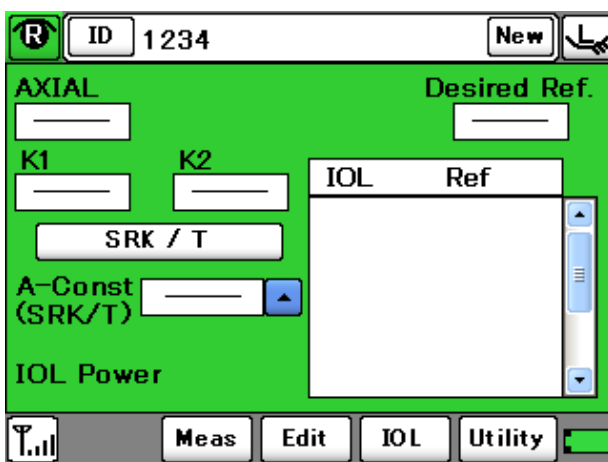

(Fig. 2)

- 2) Touch the desired formula to select it. The list closes and the selected formula is defined.

3.4.5 Saving measurement data

Note ■ Always enter the ID number when saving the measurement data in the internal memory.

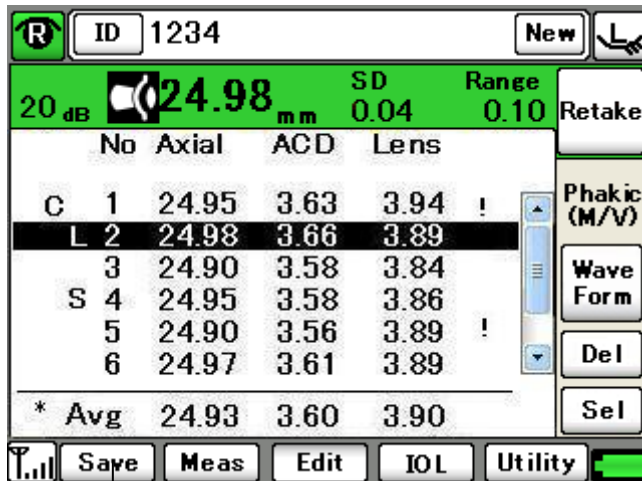

(1)

Touch the “Save” button (1) on each screen.

The “Save” button is inactive on the IOL power calculation screen and utility screen.

[Data to be saved]

- Data of 10 measurements
- Waveforms captured by 10 measurements

3.5 Pachymetry function

3.5.1 Connecting the pachymetry probe

Connect the pachymetry probe to this instrument. Refer to “3.2.1 f) Connecting the corneal thickness/A-scan diagnosis probe.”

3.5.2 Setting the data type to be displayed

Select the measurement data type to be displayed from the following three options.

- Latest: Displays the last measurement data taken.
- Minimum: Displays the minimum value of measurement data.
- Average: Displays the average of measurement data.

Refer to “3.7.2 e) Corneal Thickness Setting” for setting method.

3.5.3 Setting how to display the converted acoustic velocity and bias value

Select how to display the bias value from the following two options.

- Percentage bias
Converts the actual measurement using the preset bias rate (percentage) and displays the result.
- Plus/minus bias
Adds/subtracts the preset correction value to/from the actual measurement, and displays the result.

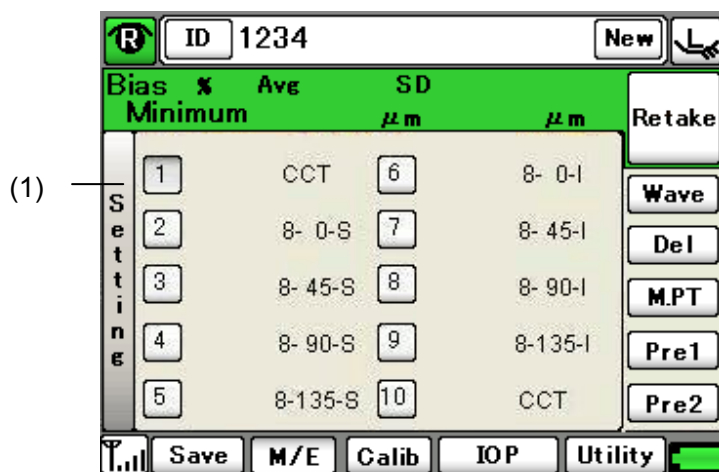

(Fig. 1)

- 1) Touch the “Setting” button (1) to open the setting screen (Fig. 2).

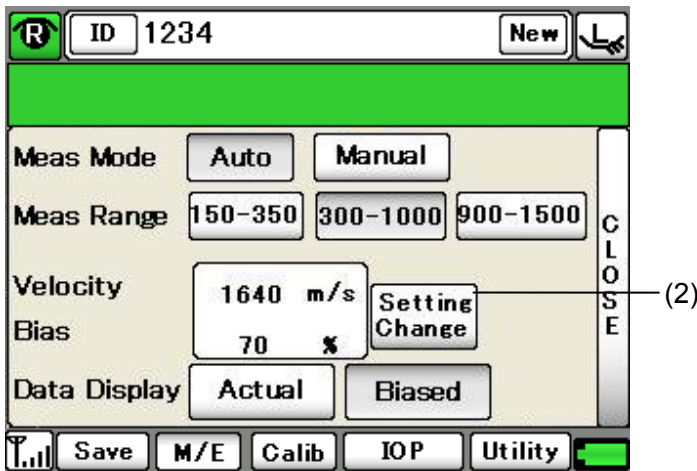

(Fig. 2)

- 2) Touch the “Setting change” button (1) to open the setting change screen (Fig. 3).

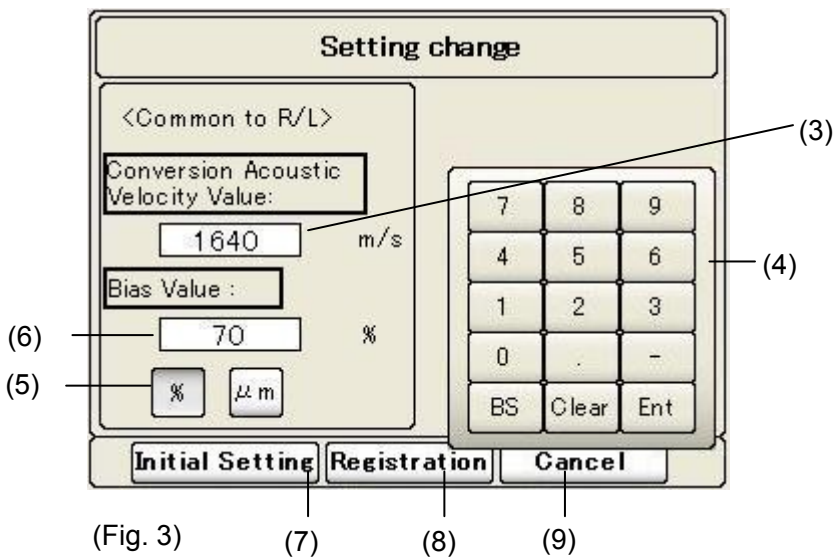

(Fig. 3)

- 3) Touch the Converted acoustic velocity Value input field (3) to activate it. The keypad (4) appears.
- 4) Enter the converted acoustic velocity using the keypad (4) and touch the “Ent” key to apply the data.
[Acceptable range]
Conversion acoustic velocity 1400 - 2000 m/s

-
- 5) Touch the “Bias Value” button (5) to select the percentage bias (%) or plus/minus bias (μm).
 - 6) Touch the bias value input field (6) to activate it. The keypad (4) appears. Using the keypad (4), enter the bias rate when the percentage bias is selected, and the correction when the plus/minus bias is selected.
[Acceptable range]
Bias rate: 60 - 130%
Correction: -600 – +450 μm
 - 7) When a value is entered for one eye, the setting for the other eye is automatically changed.
 - 8) Touch the “Initial Setting” button (7) to enter the initial settings.
 - 9) Touch the “Cancel” button (9) to ignore the entered settings and close the setting change screen.
 - 10) Touch the “Registration” button (8) to apply the entered settings and close the setting change screen.

3.5.4 Setting the measurement mode/range and data display

Select the measurement mode from the following two options.

■ Auto

Select this for measurement in Auto mode.

■ Manual

Select this when measurement is difficult in Auto mode.

Set the measurement range according to the object to be measured.

Also, set whether to display the measurement data as an actual measurement or bias value.

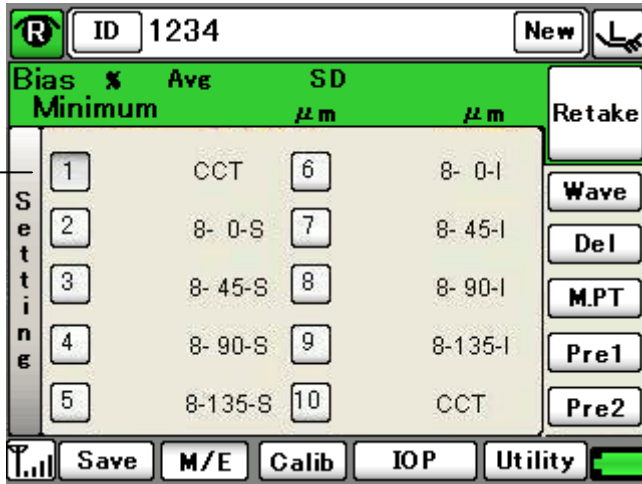

(Fig. 1)

- 1) Touch the “Setting” button (1) to display the setting screen (Fig. 2).

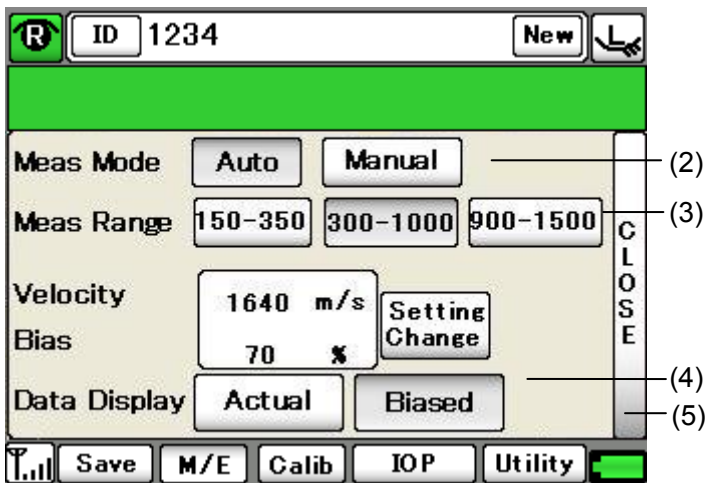

(Fig. 2)

- 2) Touch one of the “Meas Mode” buttons (2) to select the measurement mode.
- 3) Select one of the “Meas Range” buttons (3) to set the measurement range.
- 4) Select either of the “Data Display” buttons (4) to set the data display mode.
- 5) Touch the “Close” button (5) to return to the measurement screen (Fig. 1).

3.5.5 Operation check



(Fig. 1)

Note ■ *The corneal thickness test piece is for operation checks. This test piece cannot measure or calibrate the accuracy of the instrument.*

The corneal thickness test piece allows you to check the operation of the instrument.

- 1) Select "Auto" for the measurement mode.
- 2) Place the test piece in water and set the pachymetry probe perpendicularly to start measurement.

3.5.6 Preparation for measurement

Note ■ *Cooperation by the patient is required to perform measurement smoothly. Explain the purpose of the examination and measurement method to the patient before starting measurement to help them relax.*

- 1) Check the measurement condition settings and operation as needed.
- 2) Apply topical anesthesia to the eye and have the patient sit down on the chair or lie on their back so that they are in a comfortable position while measurement is performed.

3.5.7 Measurement



- *Sterilize the pachymetry probe before use.*
- *Do not use the pachymetry probe with its contact section damaged. Measurement error may occur, and the corneal may be injured.*
- *The disposable tip is a disposable part. Do not reuse it. Otherwise, you may contract diseases.*



- *The converted acoustic velocity directly affects the measurement data. Check that the desired value is set before starting measurement.*
- *The measurement data can be displayed as the actual measurement or a bias value. Check the setting of the data display mode.*
- *When the surface of the corneal is dry, wet it with saline solution.*
- *The automatic measurement function is an auxiliary function to take measurements more easily and is not a function used to actually make clinical judgment. The physician must examine the measurement result before using it.*

a) Auto measurement

- 1) Set the pachymetry probe perpendicular to the point to be measured.
- 2) The instrument automatically starts capturing measurement data when the measurement conditions are satisfied.
- 3) A beep sounds when the measurement data is captured.
- 4) When 20 sets of measurement data are captured, a beep sounds twice to indicate completion of measurement.
- 5) When the pachymetry probe is removed from the corneal, the next memory enters standby mode. Measurement is completed and the next memory allotment enters standby mode when the probe is removed from the corneal even before 20 data sets are captured.
- 6) Take measurements for all 10 memory allotments in the same manner.
- 7) When retaking measurements in a specific memory allotment during or after measurement, touch the desired memory number to enter standby mode and perform measurement again.

b) Manual measurement

- 1) Set the pachymetry probe perpendicular to the point to be measured.
- 2) The instrument beeps when the capturing conditions are satisfied.
- 3) Step on the footswitch to capture measurement data. A beep sounds when the measurement data is captured.
- 4) Repeat measurements in the same manner. When 10 sets of measurement data are taken, a beep sounds to indicate completion of measurement.
- 5) To take measurement data in the next memory allotment before 10 sets of measurement data have been taken, touch the next memory number to enter standby mode and perform measurement.
- 6) When the pachymetry probe is removed from the corneal, the next memory allotment enters standby mode.

c) Waveform display



(Fig. 1)

- 1) Measurements and waveforms are displayed while data is retrieved.

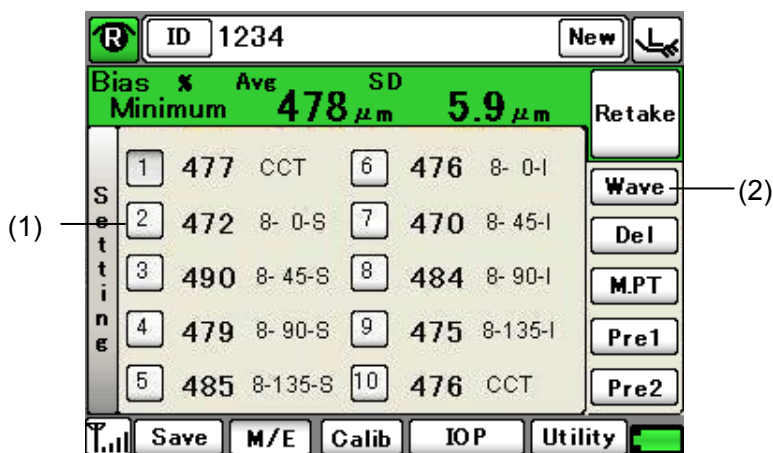

(Fig. 2)

- 2) When data capture is completed for the selected memory allotment, the memory number and measurement data (1) is displayed.
- 3) When data capture is completed or the memory allotment is in standby mode, select the memory number (1) for which measurement is completed and then touch the "Wave Form" button (2) to display the measured waveform of the selected memory number. (Fig. 3)

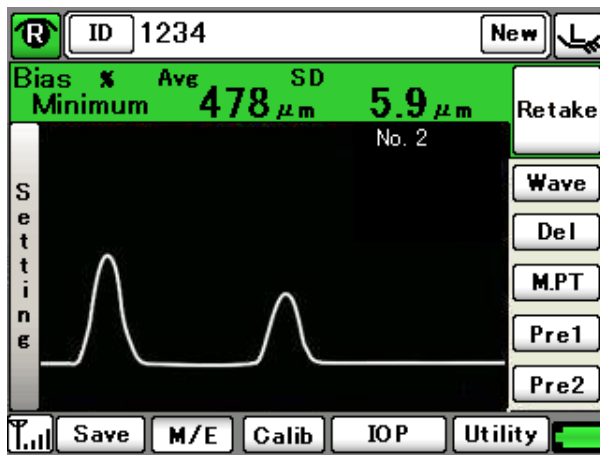

(Fig. 3)

- 4) Waveforms cannot be displayed when the data selection mode is set to "Average."

d) Measurement point display

This function displays the measurement point.

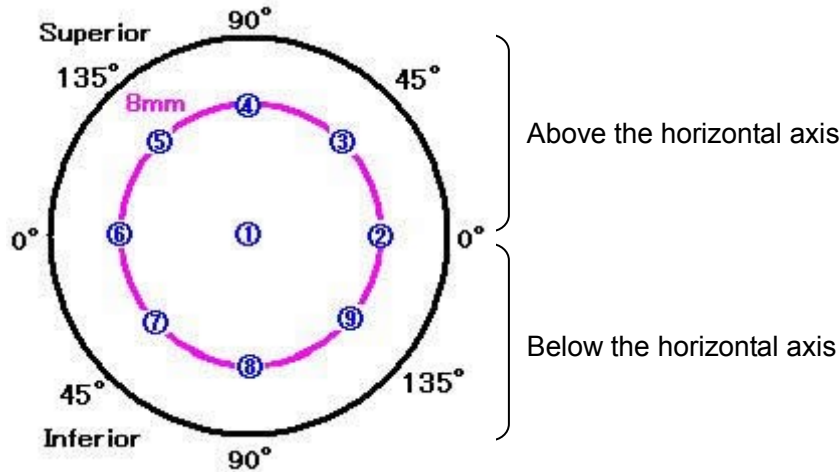

(Fig. 1)

The measurement point indicates “diameter – angle – S/I.”

- Radius Radius from the center (mm)
- Angle The upper and lower angles (°) when regarding the horizontal axis as zero degrees
- S/I Section above the horizontal axis (Superior), section below the horizontal axis (Inferior)

The center point is indicated as “CCT.”

Bias	%	Ave	SD	Minimum
1		CCT	6	8- 0-I
2		8- 0-S	7	8- 45-I
3		8- 45-S	8	8- 90-I
4		8- 90-S	9	8-135-I
5		8-135-S	10	CCT

(Fig. 2)

-
- 1) Touch the “Meas Point” button (1) to display the measurement point. This button is not available after measurement is started.

Touch the “Pre 1” or “Pre 2” button (2) to apply the contents preset on the utility screen to the measurement point. The contents of the selected presetting are displayed in the measurement data field. (Refer to “3.7.2 e) Corneal Thickness Setting.”)

e) Re-measurement of the same patient

Note *The deleted data cannot be restored. Carefully check the data before deleting it.*

Be sure to touch the “New” button to delete all the measurement data for the previous patient before measuring another patient. If the data of the next patient is captured without touching the “New” button, the patient information will not match the captured data.

Retain the patient information and delete only the measurement data for each eye. Delete all data referring to “3.2.7 Clear all measurement data (preparation for measuring a new patient)” when the patient is changed.

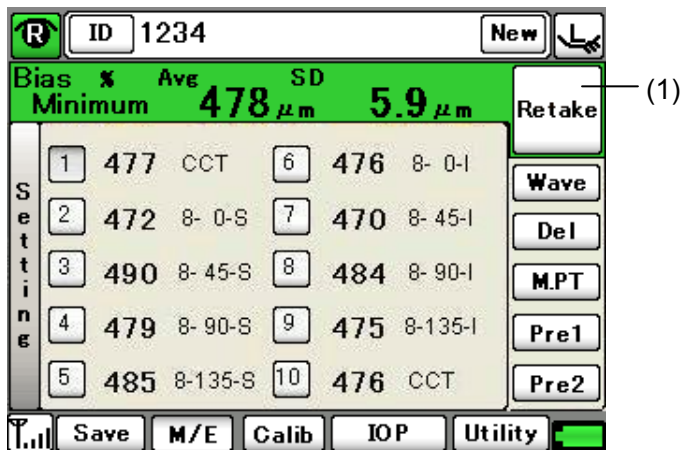

(Fig. 1)

The data for one eye is deleted.

Hold the “Retake” button (1) for approximately 1 second until a beep sounds to delete the data.

The ID, patient’s name, and gender are retained.

3.5.8 Checking the measurement data

a) Intraocular pressure correction

This instrument automatically starts calculation and displays the result when all items required for calculating the intraocular pressure correction are set.

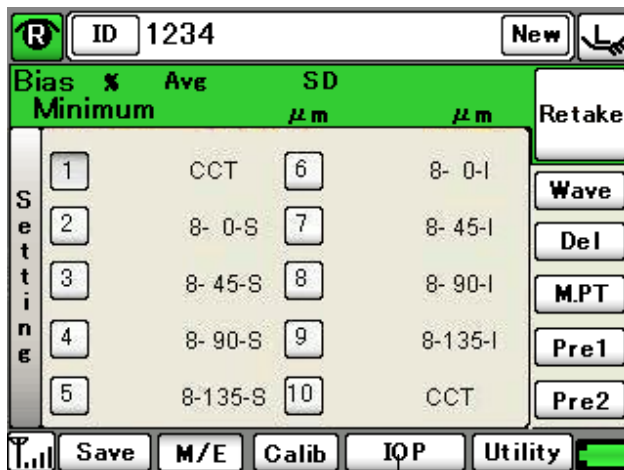

(Fig. 1)

(1)

- 1) Touch the "IOP" button (1) to open the intraocular pressure correction screen. (Fig. 2)

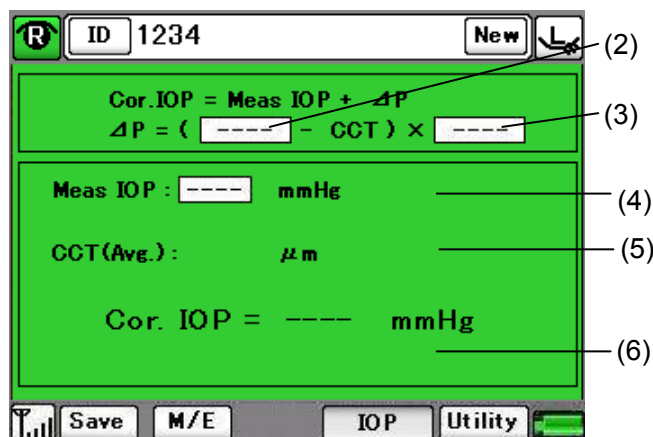

(Fig. 2)

- 2) Each input field for parameter 1 (2), parameter 2 (3), and IOP data (4) becomes active when touched, and the keypad (7) appears. (Fig. 3)

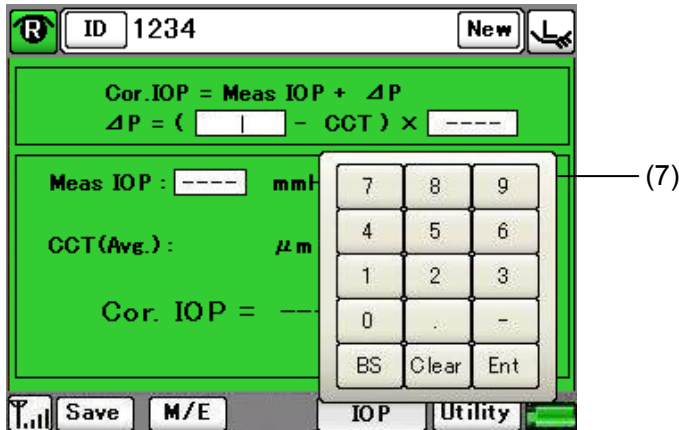

(Fig. 3)

- 3) Enter each parameter using the keypad.
 - [Acceptable range]
 - Parameter 1: 0 - 1500
 - Parameter 2: 0.0000 - 1.0000
 - Intraocular pressure data: 1.0 - 60.0 (mmHg)
1.33 – 79.99 (hPa)
- 4) The measured value is displayed in the CCT field (5) when the intraocular pressure correction screen is opened after measurement. However, if measurement points are set and one or more “CCT” is included in them, the average CCT is displayed. When measurement points are not set, the average of all memory numbers is displayed.
- 5) When all parameters are entered, the instrument automatically starts calculation and displays the corrected intraocular pressure (6).

b) Deleting part of measurement data

Note ■ *The measurement data cannot be restored once deleted. Be very careful when deleting the data.*

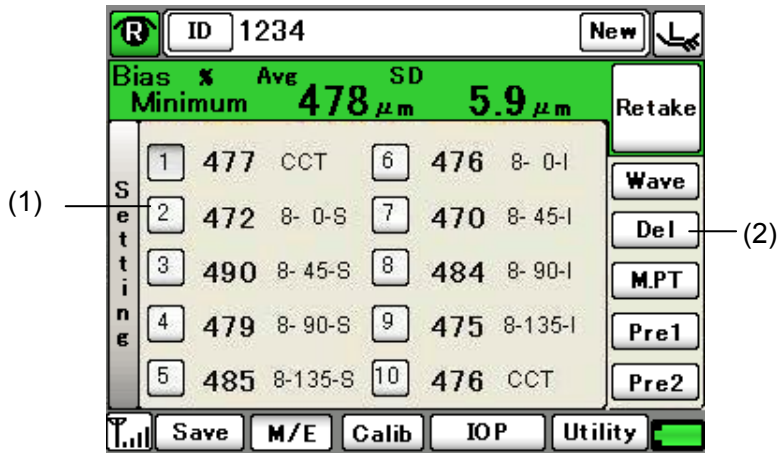

(Fig. 1)

- 1) Touch the desired memory number button (1) to select the measurement data to be deleted.
- 2) When the "Del" button (2) is touched to delete the data, the button changes to "Ret." (Fig. 2)

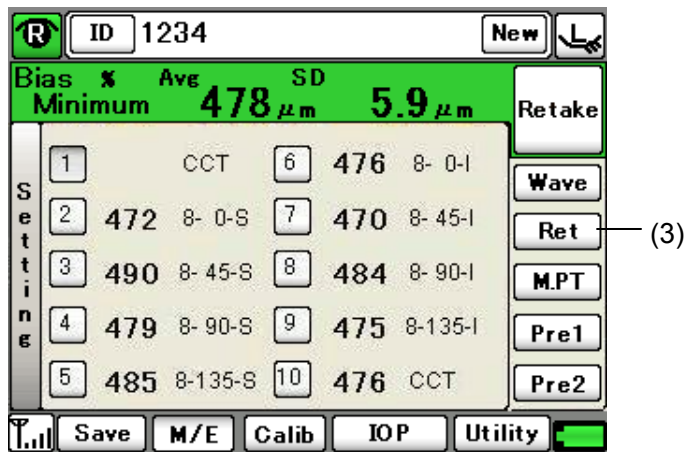

(Fig. 2)

- 3) When data is deleted by mistake or to cancel deletion of data, touch the "Ret" button (3) to restore the data. When new data is captured, the deleted data cannot be restored by pressing the "Ret" button.

3.5.9 Saving the measurement data

Note ■ Always enter the ID number when saving the measurement data in the internal memory.

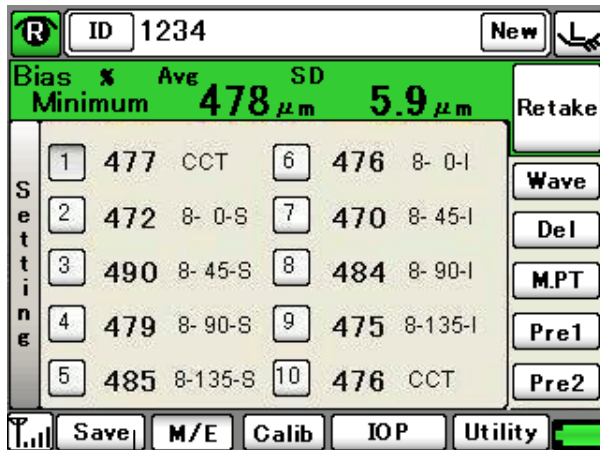

(Fig. 1) (1)

Touch the "Save" button (1).

[Data to be saved]

- Data of 10 measurements
- Waveforms captured by 10 measurements
- Each measurement point (only when measurements are taken with the measurement points displayed)

3.6 A-scan diagnosis

Note ■ *Both the A-scan diagnosis probe and biometry probe can be used for A-scan diagnosis, but the A-scan diagnosis probe is selected for operation when both probes are connected.*

3.6.1 Connecting the probe

Connect the A-scan diagnosis probe or biometry probe to this instrument. Refer to “3.2.1 c) Connecting the biometry probe” or “3.2.1 f) Connecting the corneal thickness probe/A-scan diagnosis probe.”

3.6.2 Switching to the A-scan diagnosis

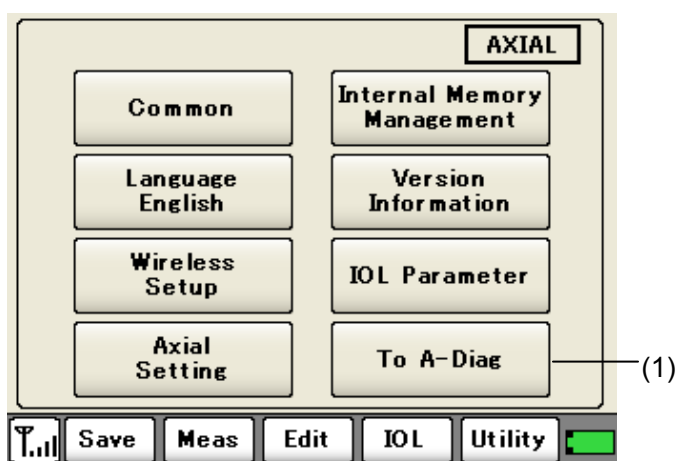

(Fig. 1)

- 1) Touch the “To A-Diag” button (1) on the utility screen of the axial length measurement function.
- 2) The initial screen to allow you to check the Ref. data when switching modes is displayed. (Fig. 1)

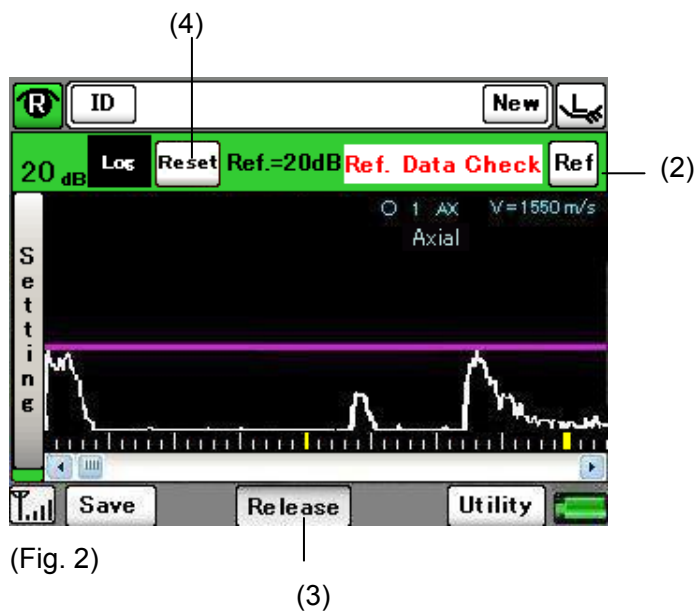

- 3) Hold the “Ref” button (2) and activate the “FREEZE” button (3) to start measurement using the registered Ref. data. Touch the “FREEZE” button (3) to start measurement..
- 4) Touch the “Reset” button (4) for two seconds to delete the Ref. data. The measurement screen appears after the Ref. data is deleted
- 5) The same initial screen appears when all measurement data is cleared (preparation for measuring a new patient). (Refer to “3.2.7 Clear all measurement data (preparation for measuring a new patient).”)

3.6.3 Gain setting

Note Settings made here are only effective for the eye currently selected. Settings cannot be made for both eyes simultaneously. Complete necessary settings for each eye.

Adjust the waveform height according to the gain settings. The gain and the waveform height increases as the gain value increases.

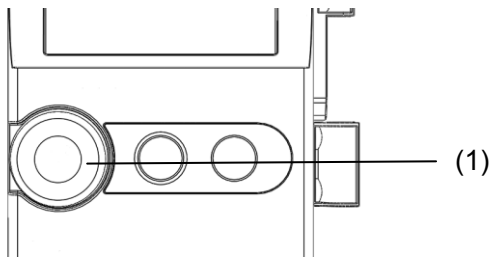

(Fig. 1)

- 1) Turn the gain adjustment knob (1) on the exterior of the instrument to set the gain. The setting is shown in the gain field (2) on the monitor.

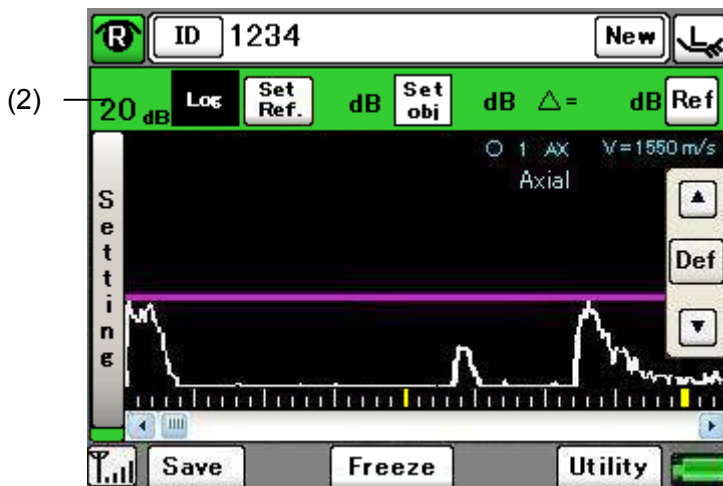

(Fig. 2)

3.6.4 Setting analysis method

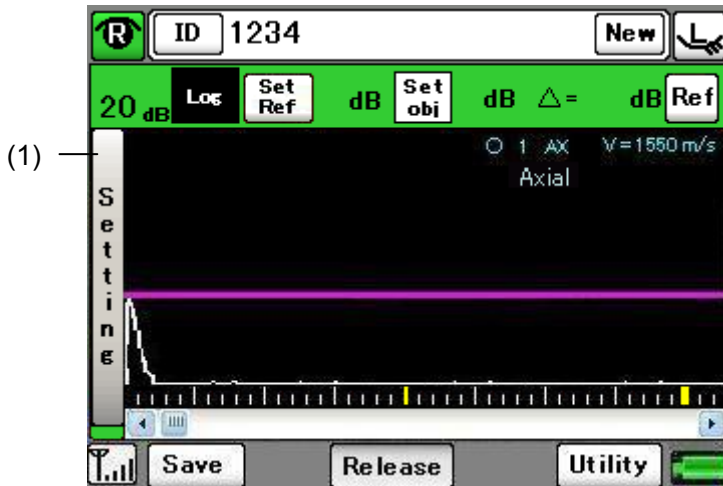

(Fig. 1)

- 1) Touch the "Setting" button (1) to display the measurement condition setting menu.

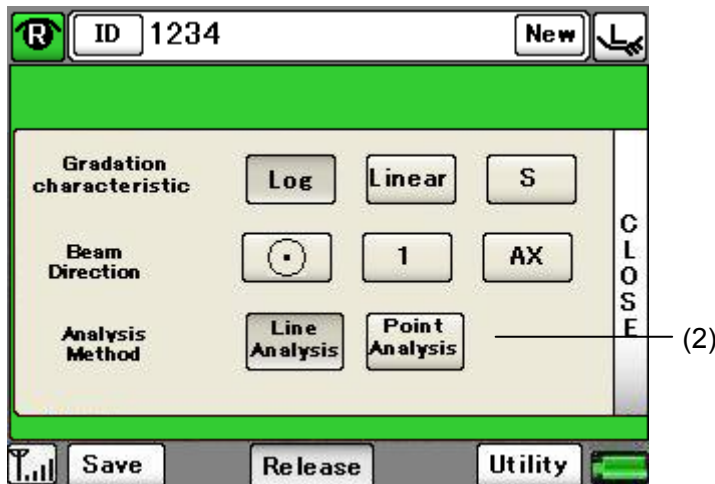

(Fig. 2)

- 2) Select either analysis method (2). When the analysis method is selected, the analysis tool changes according to the selection.

3.6.5 Measurement

Note ■ *Cooperation by the patient is required to perform examination smoothly. Explain the examination method to the patient before starting the examination to help them relax.*

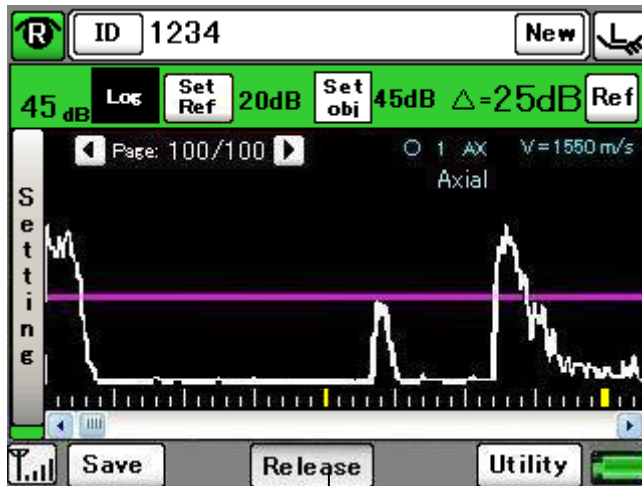

(Fig. 1)

(1)

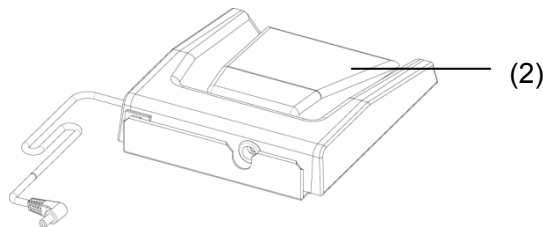

(Fig. 2)

- 1) When the instrument is in FREEZE mode, touch the “Release” button (1) or step on the FREEZE pedal (2) on the footswitch to release FREEZE mode.
- 2) Apply an appropriate amount of corneal protective agent to the contact section of the A-scan diagnosis probe.
- 3) Set the A-scan diagnosis probe to the patient’s eye to be examined.
- 4) Adjust the total gain using the rotary encoder.
- 5) Touch the “FREEZE” button (1) or step on the footswitch (2) to enter FREEZE mode when capturing mode-A waveforms.

3.6.6 Various functions in FREEZE mode

a) Switching data display

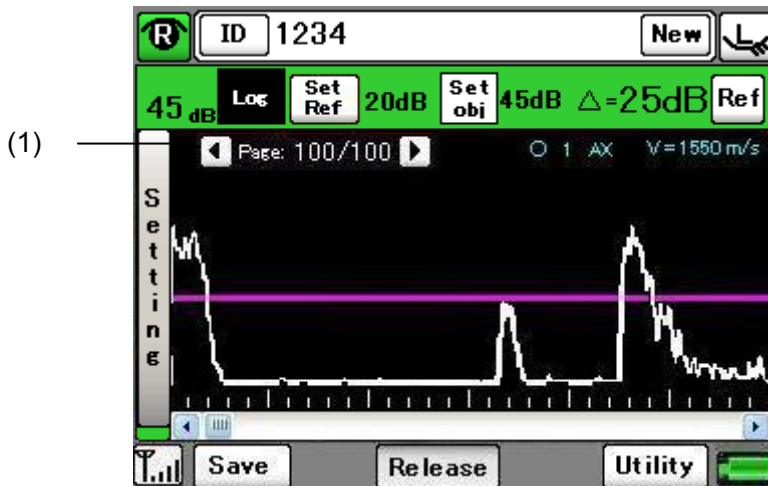

(Fig. 1)

This instrument stores waveforms for up to 100 data sets. Captured waveform data is displayed in order every time the “Page” button (1) is touched.

b) Setting the beam direction

Use this function to change the position to apply the probe or the direction of the ultrasound beam, or to display the position of a point of note (with pathological changes, etc.).

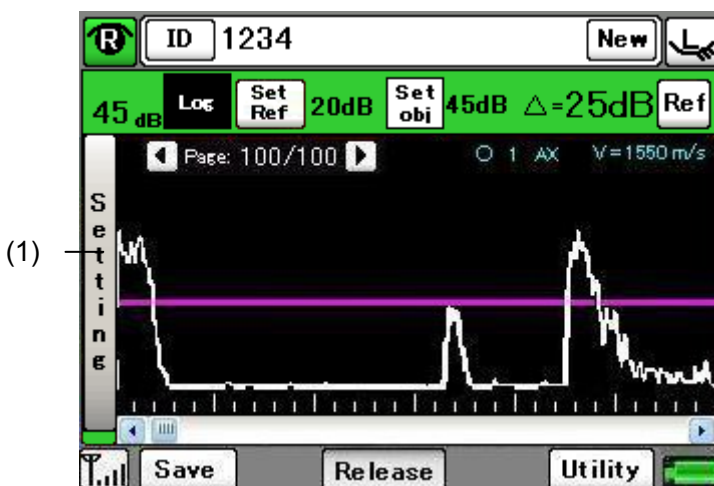

(Fig. 1)

- 1) Touch the “Setting” button (1) to display the measurement condition setting menu.

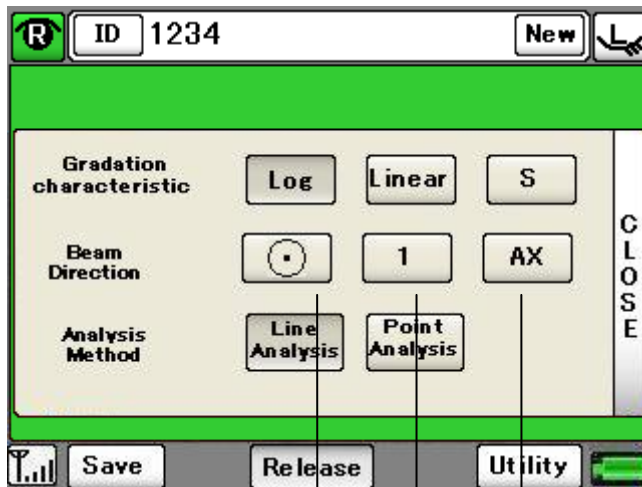

(Fig. 2)

(2)

(3)

(4)

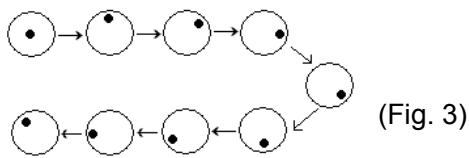

(Fig. 3)

- 2) One of the nine symbols is shown each time the probe position button (2) is touched. (Fig. 3)
- 3) Numbers from 1 to 12 appear in order every time the beam direction 1 button (3) is touched. This helps indicate the angle of the meridian. (Fig. 4)
- 4) The indicator cycles through AX → P → PE → EP → E → EA → O → CB in this order every time the beam direction 2 button (4) is touched. This helps to specify a notable point in an eyeball. (Fig. 5)

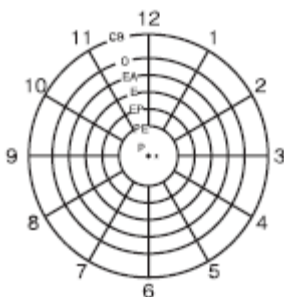

(Fig. 4)

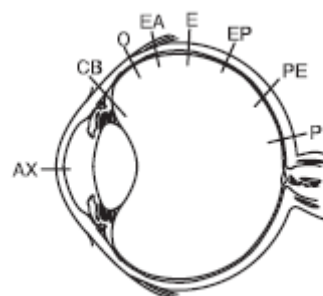

(Fig. 5)

c) Saving data

This function saves captured mode-A waveforms.

Note ■ Always enter the ID number when saving the measurement data in the internal memory.

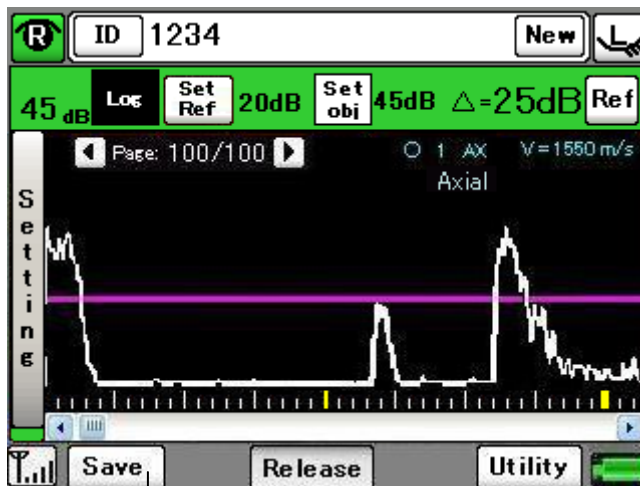

(Fig. 1)
(1)

- 1) Display the waveform data to be saved on the FREEZE screen.
- 2) Touch the "Save" button (1) to save the image displayed on the screen.

[Data to be saved]

- Data of 1 measurement
 - Waveform captured by 1 measurement (460 bytes/waveform)
 - Analysis result (Line analysis or point analysis)

3.6.7 Various functions in real time mode

a) Switching gradation characteristics

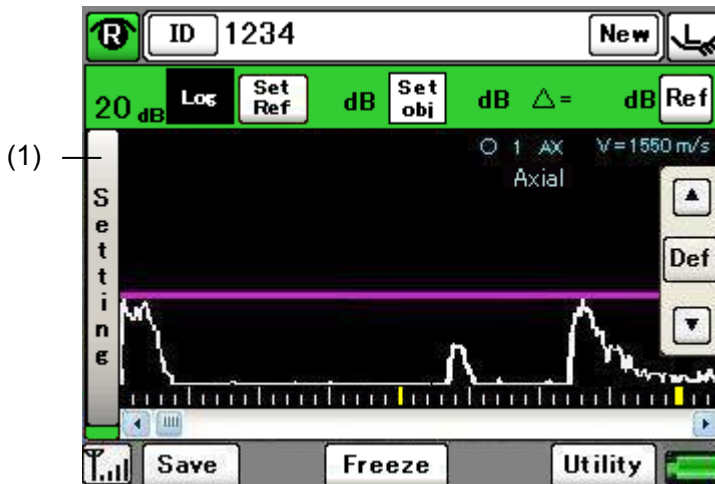

(Fig. 1)

- 1) Touch the "Setting" button (1) to display the measurement condition setting menu.



(Fig. 2)

- 2) Select a gradation characteristic (2).
The gradation characteristic can be changed only when the Ref. data is not set.

b) Setting the beam direction

Refer to "3.6.6 b) Setting the beam direction."

3.6.8 Analysis function

a) Line analysis

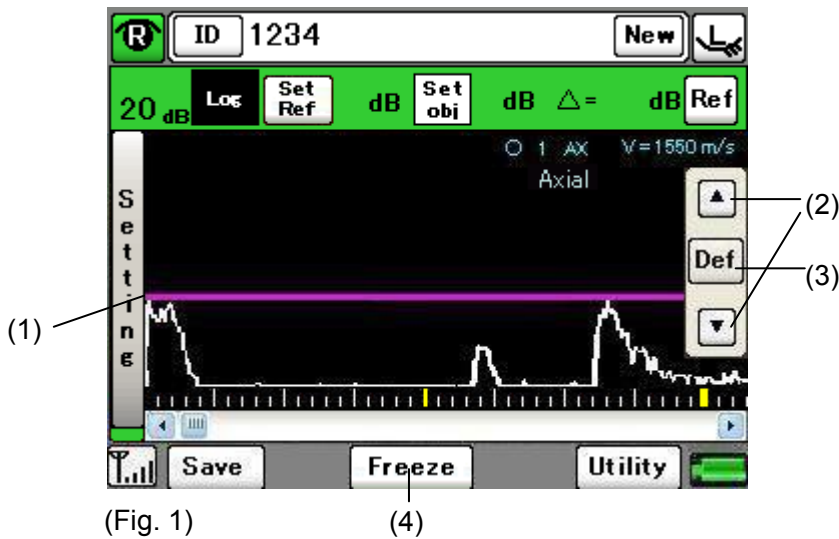

(Fig. 1)

- 1) Set the line (1) position in real time mode using the line position button (2).
- 2) Touch the “Def.” button (3) to return the line to the original position.
- 3) Adjust the gain to align the peak of the reference section (Ref. peak) with the line height.

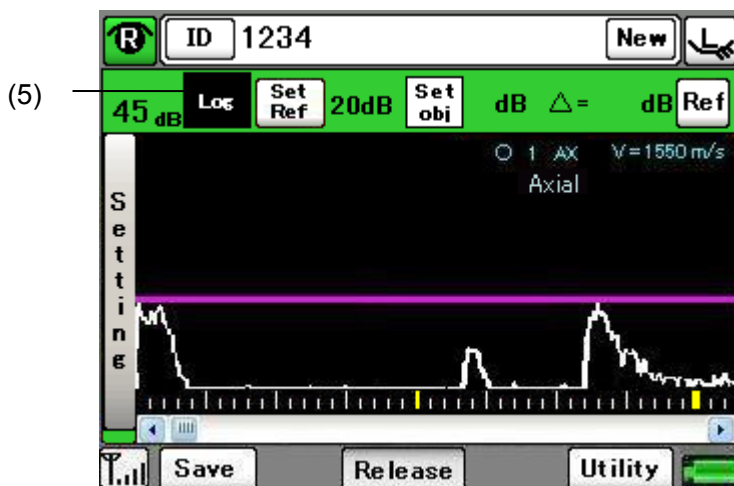

(Fig. 2)

- 4) Touch the “FREEZE” button (4) to perform measurement and then touch the “Set Ref” button (5). The value displayed in the gain field is set to the Ref. gain.

- 5) Release FREEZE mode again and align the peak of the object section (Obj. peak) with the line height.

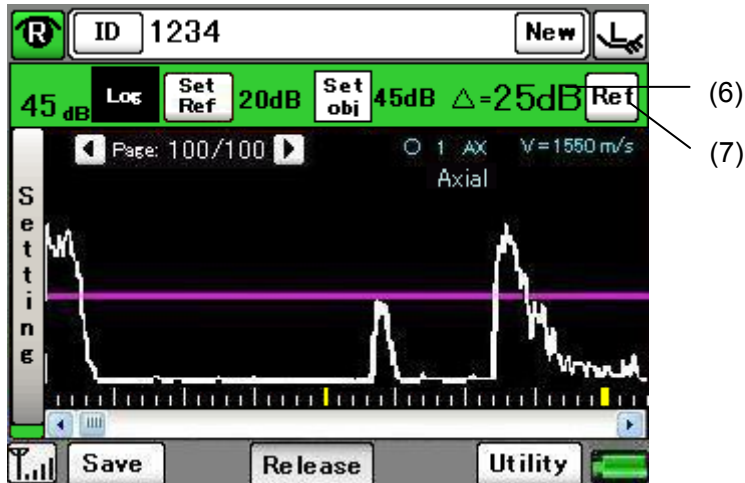

(Fig. 3)

- 6) After measurement is completed by touching the “FREEZE” button (4), the gain of the waveform currently displayed automatically appears beside “Set Obj.” When changing the page by touching the page button, the gain shown beside “Set Obj” also changes to the gain of the waveform displayed on the current page.
- 7) The difference between the Ref. gain and Obj. gain is displayed (6).
- 8) When FREEZE mode is released after the result is displayed, the Obj. gain is cleared.
- 9) Touch the “Ref” button (7) to open the Ref. Data display screen to set the Ref. gain again.
Refer to “3.6.2 Switching to the A-scan diagnosis” for how to delete the Ref. Data.

b) Point analysis

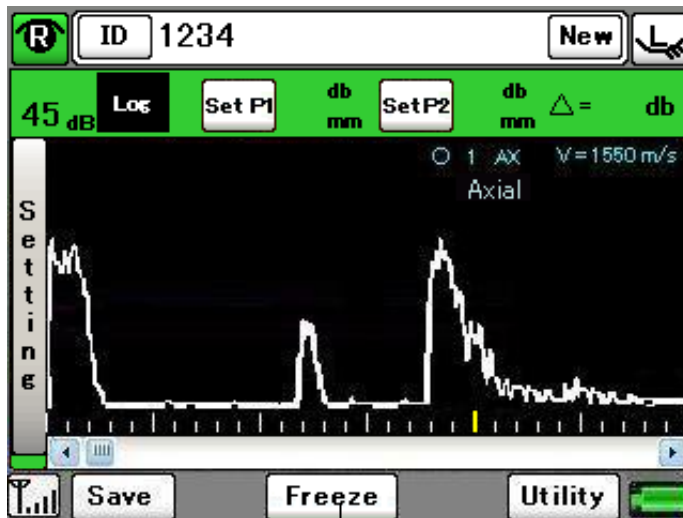

(Fig. 1)

(1)

- 1) When measurement is completed by touching the “FREEZE” button (1), the cursor (2) appears in the waveform monitor screen. (Fig. 2)

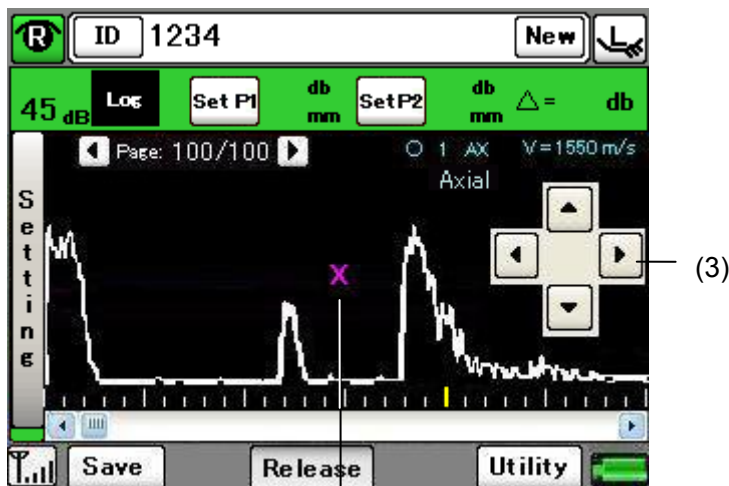

(Fig. 2)

(2)

(3)

- 2) Move the cursor using the cursor movement button (3) to the position to be set in P1.
- 3) When the “Set P1” button is touched, the P1 mark (4) appears at the current cursor position and the gain at the cursor position is set as P1.(5)

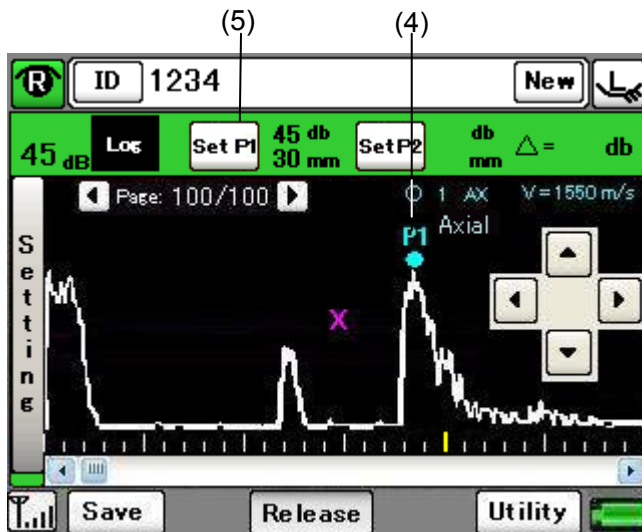

(Fig. 2)

- 4) Move the cursor again to the position to be set in P2.
- 5) When the “Set P2” button is touched, the P2 mark (6) appears at the current cursor position and the gain at the cursor position is set as P2.(7)
- 6) The difference between P1 and P2 appears when P1 and P2 are set.(8)

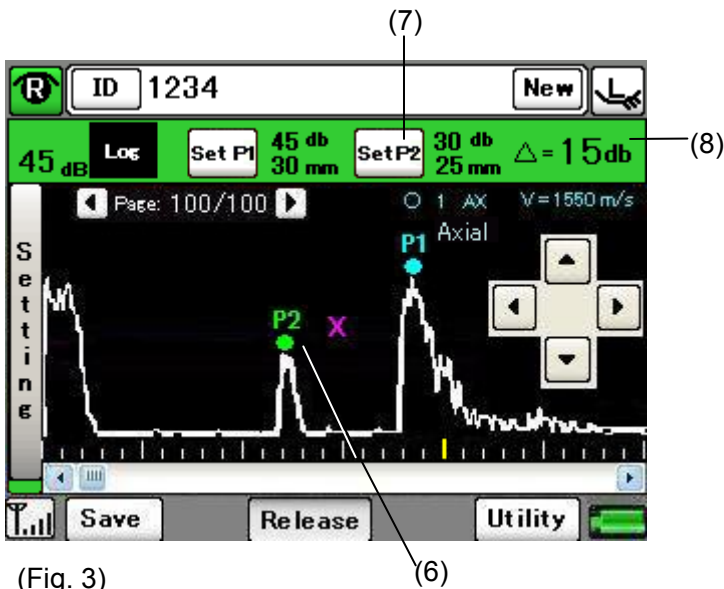

(Fig. 3)

- 7) To correct the position of P1 or P2, move the cursor and touch the “Set P1” or “Set P2” button again. The setting is overwritten and the difference between the new P1 and P2 appears.
- 8) When FREEZE mode is released while analysis is performed or after analysis is completed, the analysis result will be deleted.

3.7 Utilities

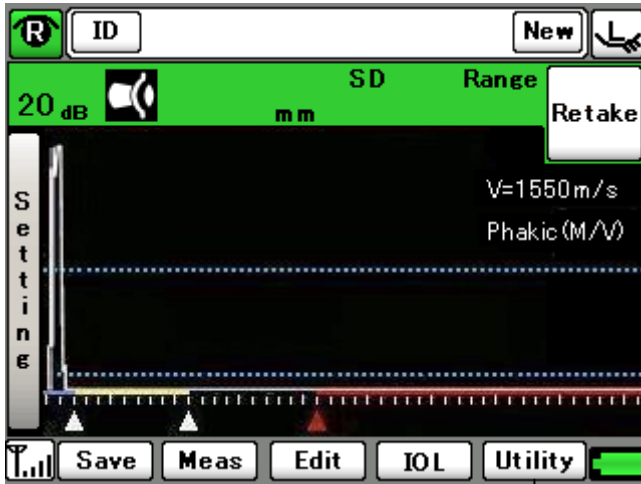

(Fig. 1)

(1)

- 1) Touch the “Utility” button (1) on each screen to open the utility menu screen (Fig. 2).

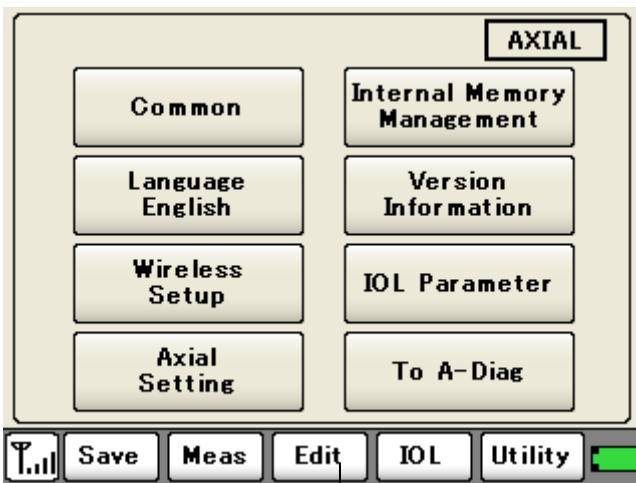

(Fig. 2)

(3)

- 2) Touch any of the setting item buttons (2) on the screen to open the corresponding setting screen. Refer to 3.7.1 and the following sections for details.
- 3) Touch the target screen button (3) to apply the setting and close the utility screen.

3.7.1 Buttons and icons on the screen

a) Utility menu screen of axial length measurement function

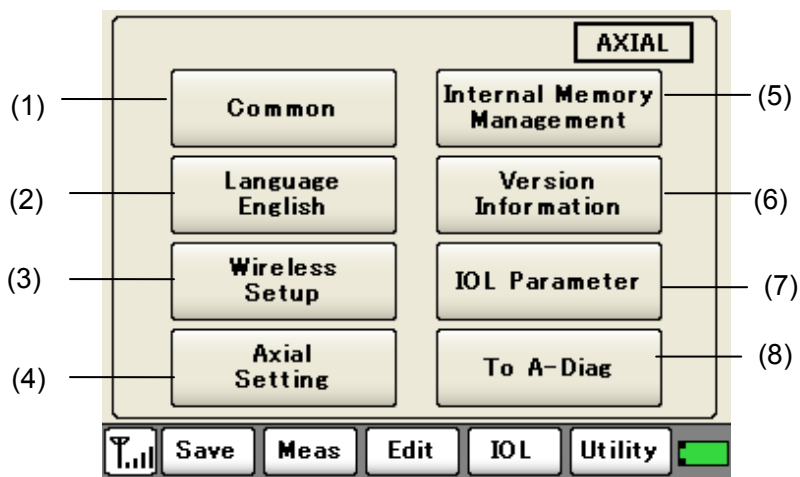

(1) Common Setting

Set the sound volume, screen brightness, auto power off, and date/time.
Refer to “3.7.2 a) Common Setting” for setting method.

(2) Language Setting

Set the language.
Refer to “3.7.2 b) Language Setting” for setting method.

(3) Radio Comm. Setting

Set the wireless communication.
Refer to “3.7.2 c) Wireless Communication Setting” for setting method.

(4) Eye Axis Setting

Make the settings related to measurement of the axial length.
Refer to “3.7.2 d) Eye Axis Setting” for setting method.

(5) Internal Memory Management

Set the internal memory in this instrument.
Refer to “3.7.2 f) Internal Memory Management” for setting method.

(6) Version Information

Displays the version information.
Refer to “3.7.2 g) Version Information” for setting method.

(7) IOL Parameter Setup

Registers the parameters that are used in IOL calculation.

Refer to “3.7.2 h) Registering IOL parameters” for the setting method.

(8) To A-Diag

Hold this button for two seconds to go to the A-scan diagnosis.

b) Utility menu screen of corneal thickness measurement function

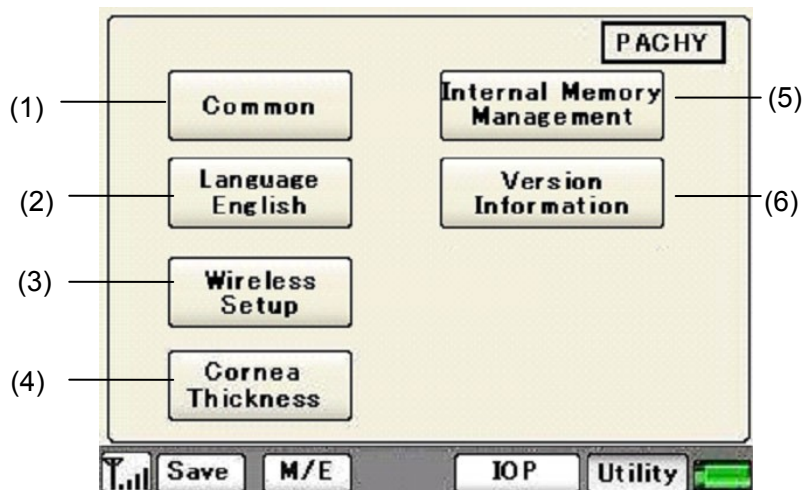

(1) Common Setting

Set the sound volume, screen brightness, auto power off, and date/time.
Refer to “3.7.2 a) Common Setting” for setting method.

(2) Language Setting

Set the language.
Refer to “3.7.2 b) Language Setting” for setting method.

(3) Radio Comm. Setting

Set the wireless communication.
Refer to “3.7.2 c) Wireless Communication Setting” for setting method.

(4) Cornea Thickness

Set the method for selecting the corneal thickness data.
Refer to “3.7.2 e) Corneal Thickness Setting” for setting method.

(5) Internal Memory Management

Set the internal memory in this instrument.
Refer to “3.7.2 f) Internal Memory Management” for setting method.

(6) Version Information

Displays the version information.
Refer to “3.7.2 g) Version Information” for setting method.

c) Utility screen of A-scan diagnosis

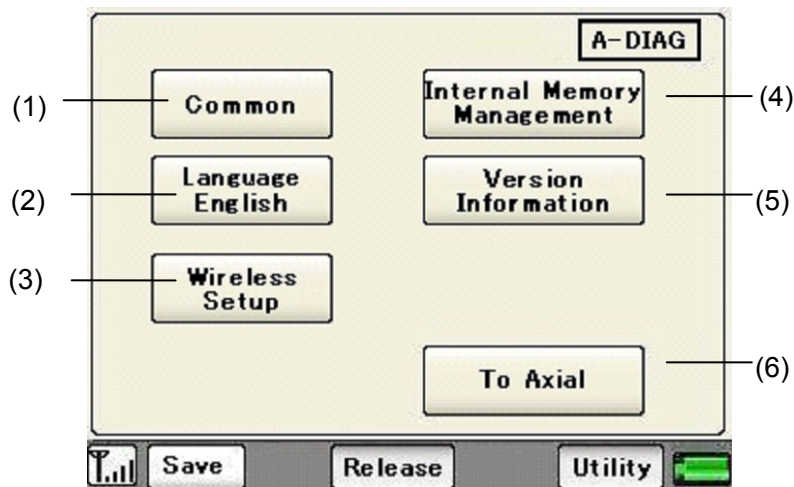

(1) Common Setting

Set the sound volume, screen brightness, auto power off, and date/time.
Refer to “3.7.2 a) Common Setting” for setting method.

(2) Language Setting

Set the language.
Refer to “3.7.2 b) Language Setting” for setting method.

(3) Radio Comm. Setting

Set the wireless communication.
Refer to “3.7.2 c) Wireless Communication Setting” for setting method.

(4) Internal Memory Management

Set the internal memory in this instrument.
Refer to “3.7.2 f) Internal Memory Management” for setting method.

(5) Version Information

Displays the version information.
Refer to “3.7.2 g) Version Information” for setting method.

(6) To Axial

Hold this button for two seconds to go to the axial length measurement function.

3.7.2 Operations for each setting

“Common Settings” are parameters common to all modes.

a) Common Setting

[Page 1/3: Volume and Screen Brightness]

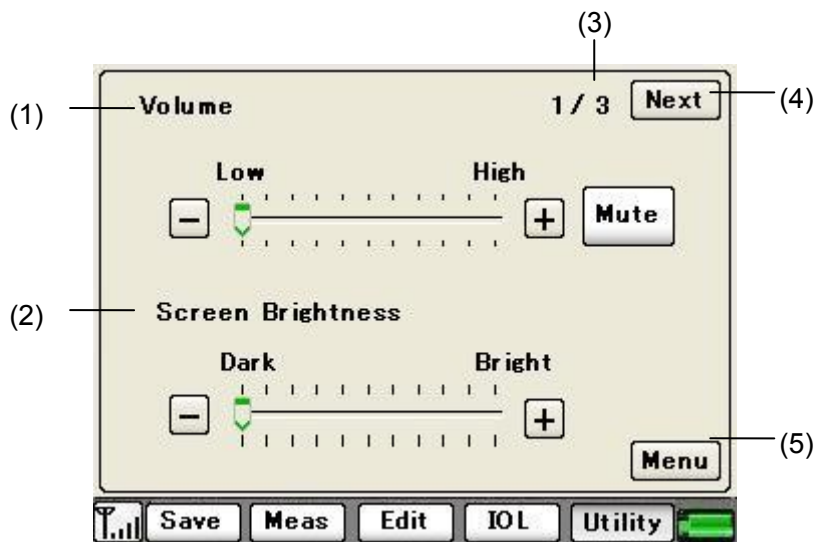

(1) Volume

Set the sound volume. Touch the “Mute” button to set the volume to “0.”

-: Low

+: High

(2) Screen Brightness

Set the brightness of the monitor screen.

-: Dark

+: Bright

(3) Page No.

The page number currently displayed (page number of “Common Setting”) is shown.

(4) “Next” button

Calls the next page in “Common Setting.”

(5) “Menu” button

Opens the utility menu screen.

[Page 2/3: Auto Power Off]

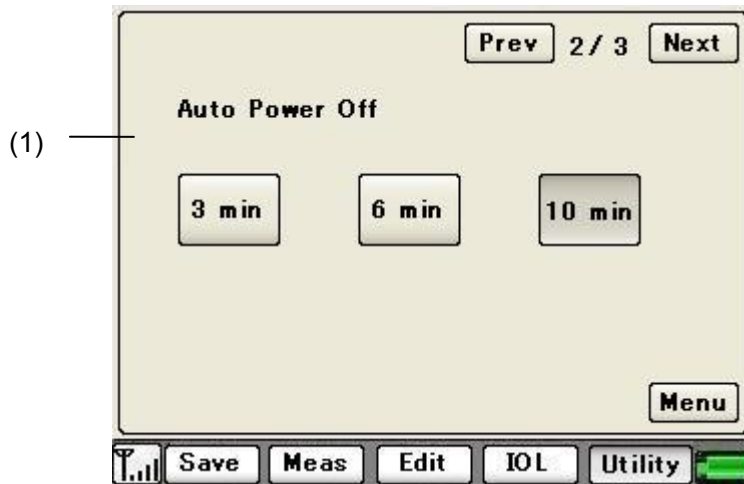

(1) Auto Power Off

Set the time until Auto Power Off mode (to turn power off) is activated.

3 min / 6 min / 10 min

When measurement data is retained when the Auto Power Off function is activated, the measurement data is automatically saved.

Refer to “3.7.2 f) Internal Memory Management” for how to check the saved data.

[Page 3/3: Date & Time Setting]

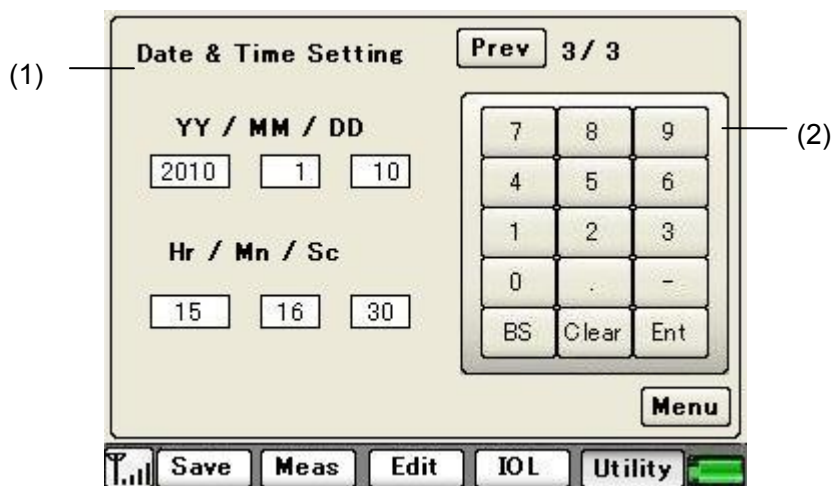

(1) Date & Time Setting

Set the date and time. Set the parameters for date and time using the keypad (2).

Y/M/D

Hour: Minute: Second

b) Language Setting

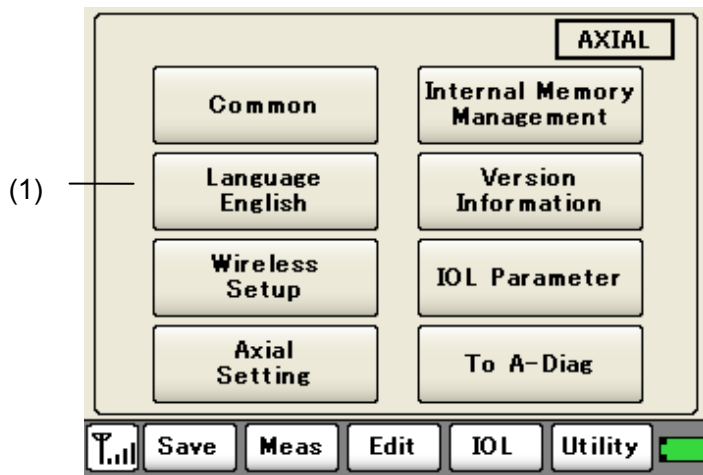

(1) Language Setting

Touching the "Language Setting" button changes the language between "Japanese" and "English."

c) Wireless Communication Setting

[Page 1/2]

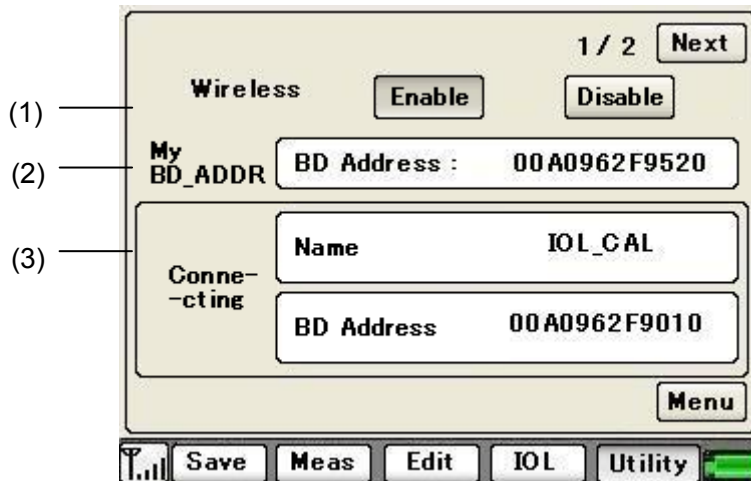

Note ■ While the utility screen is opened on a device during wireless communication, operation of the other device is disabled. Disable wireless communication to open the utility screen on both devices at the same time.

Settings for wireless communication with UD-8000, IOL calculation unit, and PC KIT are described in this section.

Settings for wireless communication need to be made on each device to be connected. Refer to the instruction manual of each device for these settings.

(1) Wireless Communication Button

Enables or disables wireless communication.

Permit: Wireless communication is enabled.

Prohibit: Wireless waves for wireless communication are stopped and wireless communication is disabled.

(2) BD Address Display of Bureau

The BD address of the device is displayed.

(3) Target Place

The target place name and BD address are displayed. These fields are blank when nothing is connected.

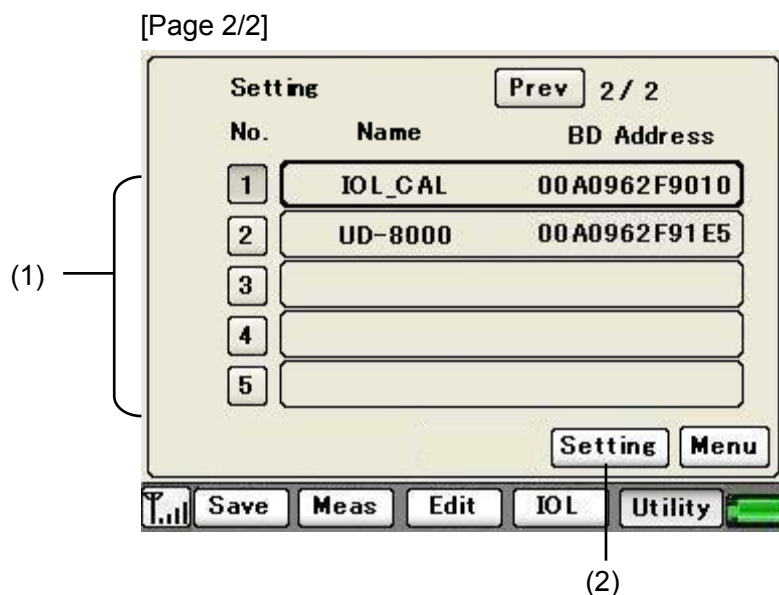

(1) Connection place list

Registered devices to be connected and their BD addresses are listed.

(2) "Setting" button

Opens the connection setting screen.

[Connection setting screen]

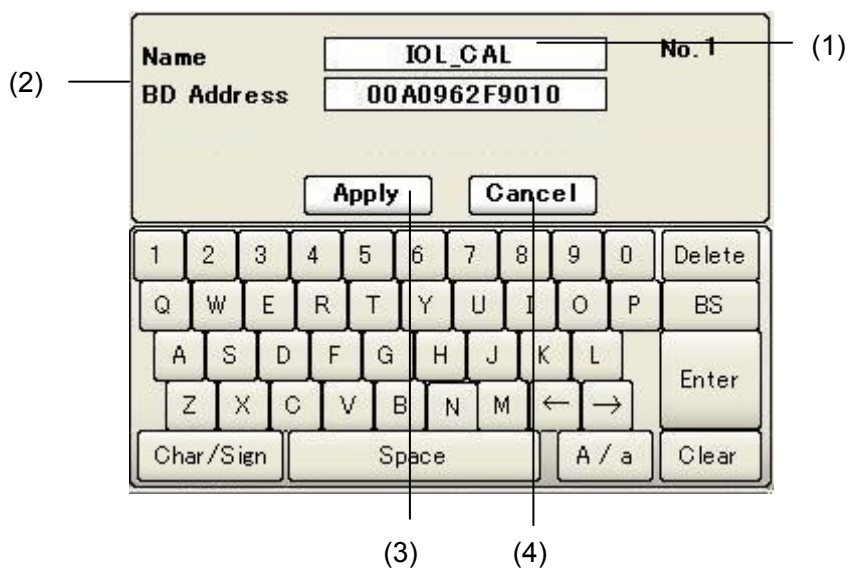

(1) Connection place name

Enter the name for the connection place.

The desired display name can be set for each connection place. This name is displayed in the connection list on the wireless communication setting screen or connection selection screen.

(2) BD Address

The BD address of the connected device is displayed.

<BD address setting examples>

The following describes the settings on each device when the BD address of each device to be connected is as listed in Table 1.

Table 1: BD address examples of each device

BD address example of this instrument	00A0962F952 0	BD address example of the device to be connected Example: IOL calculation unit	00A0962F9010
---------------------------------------	------------------	---	--------------

Table 2: Setting contents on “connection setting screen” of each device

Settings of this instrument		Settings of the IOL calculation unit (connection place)	
Connection place name	IOL_CAL	Connection place name	AL4000 MEAS2
Automatically obtain BD address	00A0962F9010	BD address	00A0962F9520

- 1) When starting connection with the settings as listed in Table 2 for the partner device, the BD address of that device is automatically set in this instrument.
 - Connection place name: Set the desired name.
 - BD address: The BD address of the connected device is automatically set.
- 2) Select this instrument as a “connection place” on the wireless communication setting screen of the partner device.
- 3) Select “Permit” for “Wireless Communication” on the wireless communication setting screen on both devices.

(3) “Apply” button

Applies the entered settings and returns to the top page of the wireless communication setting screen.

(4) “Cancel” button

Cancels the entered settings and returns to the top page of the wireless communication setting screen.

d) Eye Axis Setting

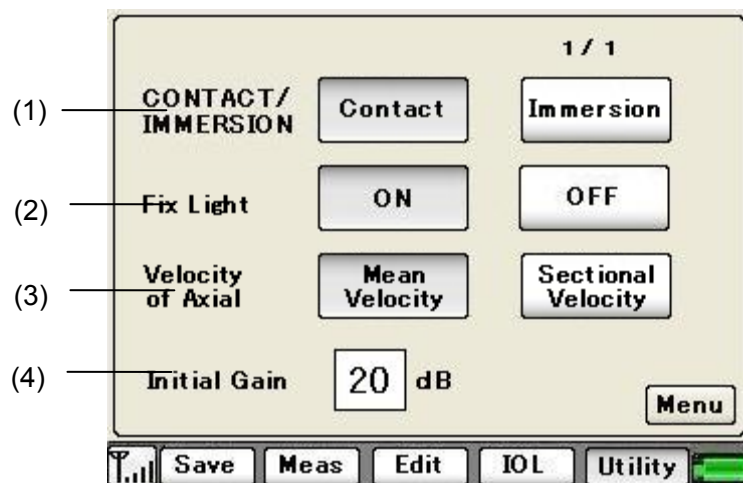

(1) Select contact mode / immersion mode

Select the mode for measuring the axial length.

CONTACT / IMMERSION

(2) Probe Light

Select whether the fix light in the biometry probe is turned on or off.

(3) Calculation Method

Select the method to calculate the axial length.

Average Speed / Division Speed

(4) Initial Gain

Set the gain when axial length mode is started and when a new patient is examined.

The key pad appears when the entry field is touched.

Enter the desired setting.

[Acceptable range]

Initial gain: 0 – 40 dB

e) Corneal Thickness Setting

[Page 1/2: Data Selection Method / IOP]

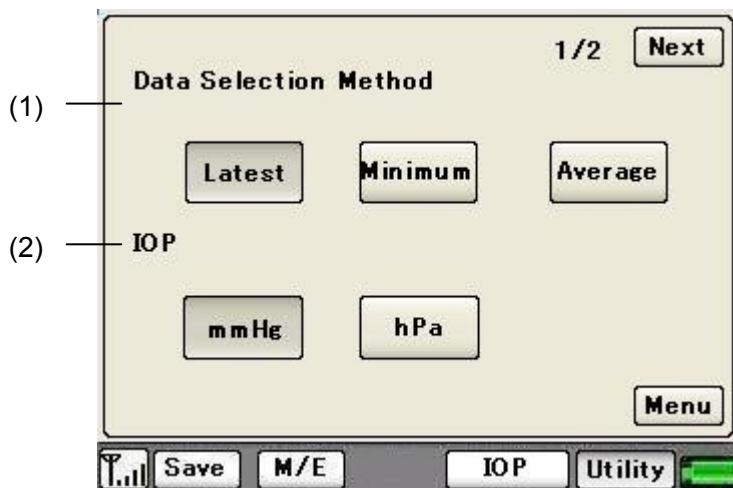

(1) Data Selection Method

Select the measurement data type to be displayed.

Latest / Minimum / Average

(2) IOP

Select the units for intraocular pressure correction.

mmHg / hPa

[Page 2/2: Measurement Selection]

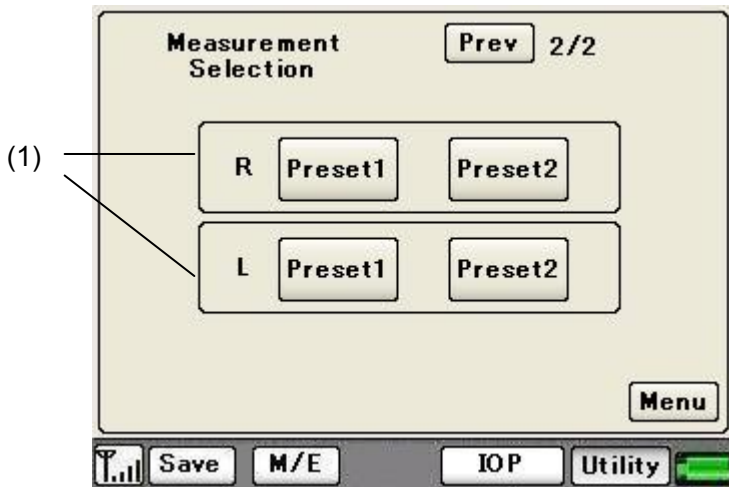

(1) Measurement point

Selects measurement points to be edited and opens the measurement point edit screen.

[Measurement point edit screen]

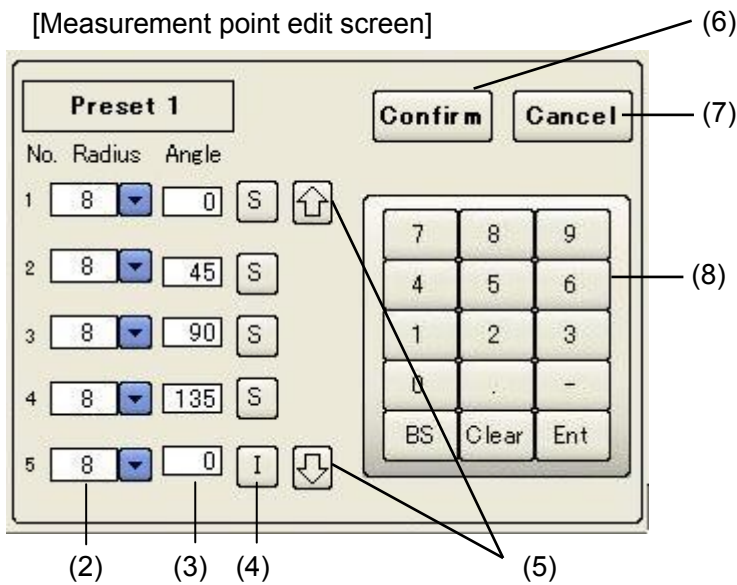

(2) Radius

Specify the distance from the center of the measurement point. Select CCT or enter the desired value using the keypad (8).

[Acceptable range]
Radius: 0.00 - 15.00 mm

(3) Angle

Enter the angle from the horizontal axis at the measurement point.

[Acceptable range]

Angle: 0 - 179

(4) S/I selection button

Touching this button changes the setting between “S” and “I.”

(5) UP/DOWN arrow buttons

Switches memory number groups (Nos. 1 – 5 and 6 – 10) to be listed.

(6) “Confirm” button

Applies the changes and returns to the previous screen.

(7) “Cancel” button

Ignores changes and returns to the previous screen.

f) Internal Memory Management

Note ■ *The measurement data cannot be restored once deleted. Be very careful when deleting the data.*

■ *When initialization is performed, all data in the internal memory is cleared and cannot be restored. Be very careful when performing initialization.*

The patient data saved in the internal memory is displayed and edited on this screen.

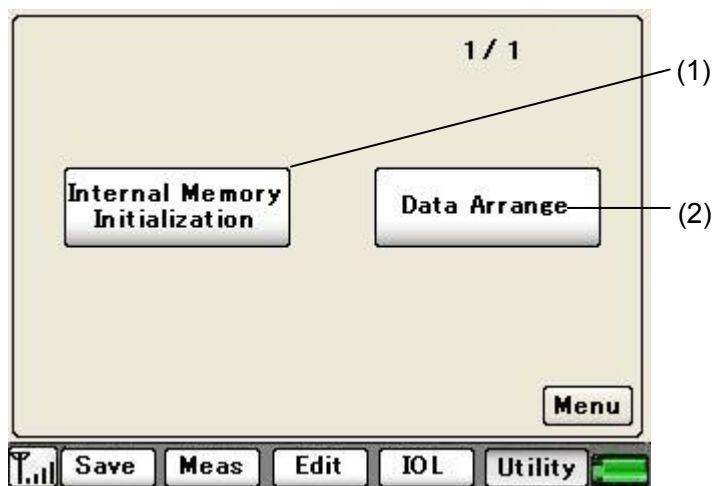

(1) Internal Memory Initialization

Hold this button for two seconds to initialize the internal memory.

(2) Data Arrange

Displays a list of data in this instrument.

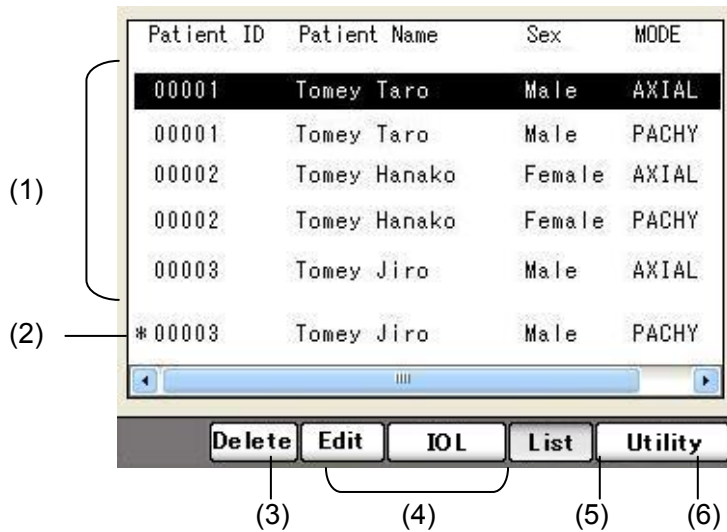

(1) Saved data list

The data saved in the internal memory of the measurement unit is listed. Data for up to 5 measurements can be saved.

Patient ID / Patient Name / Sex / MODE / Measurement date and time / Physician

(2) Data saved by Auto Power Off

The data automatically saved when the Auto Power Off function is activated is displayed. "*" is assigned to the data saved by the Auto Power Off function. Only 1 measurement can be saved automatically.

(3) "Delete" button

Deletes the selected data from the internal memory in the measurement unit. The data for both eyes is deleted.

(4) Mode-specific operation buttons

Different buttons appear depending on the mode of the selected data. Refer to the explanation of the mode-specific buttons described below.

(5) "List" button

Displays the data list screen.

(6) "To Utility" button

Returns to the internal memory setting screen of the utility.

[When selecting axial length measurement data]

Patient ID	Patient Name	Sex	MODE
00001	Tomey Taro	Male	AXIAL
00001	Tomey Taro	Male	PACHY
00002	Tomey Hanako	Female	AXIAL
00002	Tomey Hanako	Female	PACHY
00003	Tomey Jiro	Male	AXIAL
* 00003	Tomey Jiro	Male	PACHY

Below the table is a horizontal scroll bar and a row of five buttons: **Delete**, **Edit**, **IOL**, **List**, and **Utility**.

(1)

(2)

(1) "Edit" button

Displays the selected measurement data on the edit screen.

(2) "IOL" button

Displays the selected measurement data on the IOL power calculation screen.

[When selecting corneal thickness measurement data]

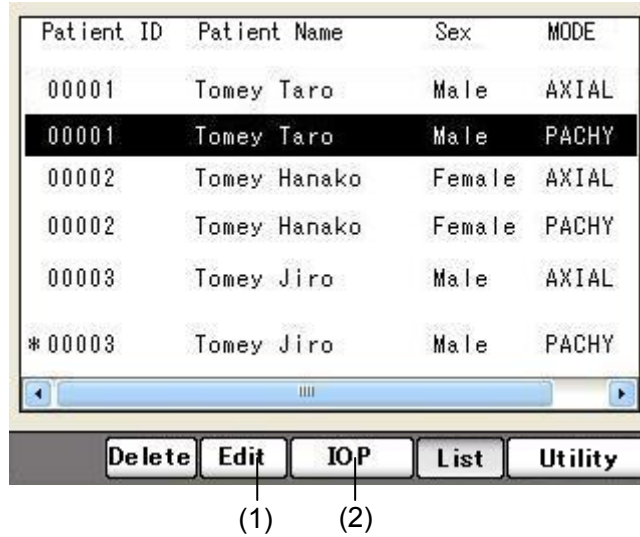

(1) "Edit" button

Displays the selected measurement data to the measurement/edit screen.

(2) "IOP" button

Displays the selected measurement data on the intraocular pressure correction screen.

[When selecting A-scan diagnosis data]

Patient ID	Patient Name	Sex	MODE
00001	Tomey Taro	Male	A-DIAG
00001	Tomey Taro	Male	PACHY
00002	Tomey Hanako	Female	AXIAL
00002	Tomey Hanako	Female	PACHY
00003	Tomey Jiro	Male	AXIAL
* 00003	Tomey Jiro	Male	PACHY

Below the table is a horizontal scrollbar and a row of four buttons: **Delete**, **Meas.**, **List**, and **Utility**.

(1)

(1) "Meas." Button

Displays the selected measurement data.

g) Version Information

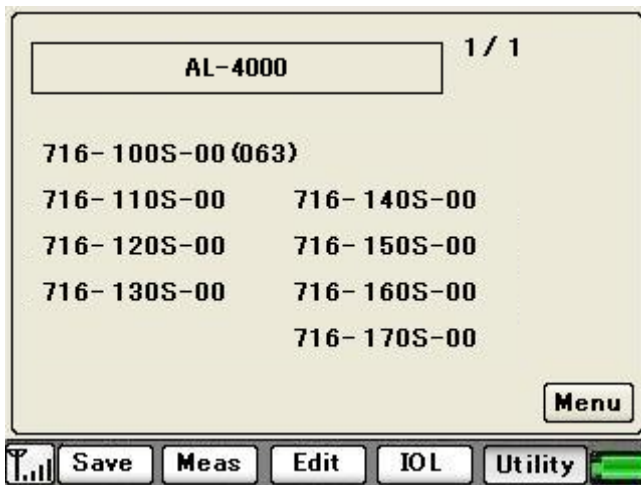

Displays the version information of this instrument.

h) Registering IOL parameters

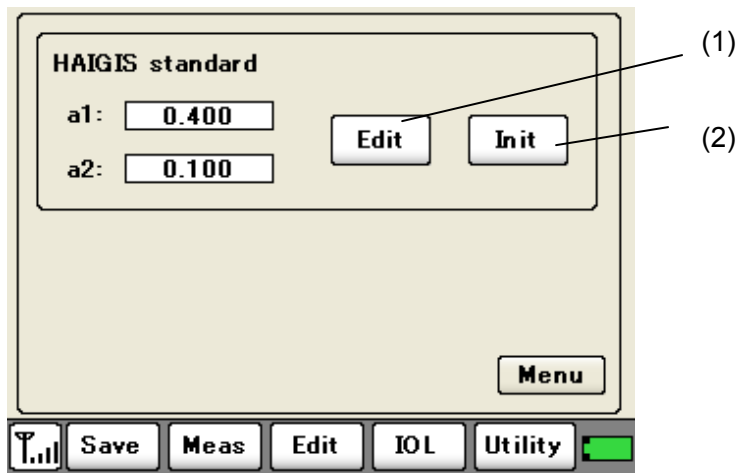

Parameter setting for HAIGIS standard formula

Set parameters for the HAIGIS standard formula. Holding the “Edit” button (1) for approximately 1 second displays the keypad to allow you to enter a parameter. Holding the “Init” button (2) for approximately 1 second automatically enters the default parameter.

[Acceptable range]

a1: -0.999 - 0.999

a2: -0.999 - 0.999

4. TECHNICAL INFORMATION

4.1 IOL power calculation formula

4.1.1 SRK-II formula

1. Implanted IOL power (D) for emmetropization)

$$P_{emme} = A1 - 0.9K - 2.5L$$

2. Implanted IOL power (D) for ametropia

$$P_{amet} = P_{emme} - REF \cdot CR$$

3. Predicted refractive power after surgery (D)

$$REF_{iol} = (P_{emme} - P) / CR$$

Where

$L < 20.0$	$\rightarrow A1 = A + 3$
$20.0 \leq L < 21.0$	$\rightarrow A1 = A + 2$
$21.0 \leq L < 22.0$	$\rightarrow A1 = A + 1$
$22.0 \leq L < 24.5$	$\rightarrow A1 = A$
$24.5 \leq L$	$\rightarrow A1 = A - 0.5$

$$P_{emme} \leq 14 \rightarrow CR = 1.00$$

$$P_{emme} > 14 \rightarrow CR = 1.25$$

A : A-Constant

KK: Average corneal refractive power (D)

$$= (K1 + K2) / 2$$

L : Axial length (mm)

P : Implanted IOL power (D)

REF : Desired refractive power after surgery

4. Personal A - Constant

$$A = P + AREF \cdot RF + 2.5L + 0.9K - COR$$

Where

AREF: Eye refractive power after surgery (D)

RF : Refractive factor

$$P > 16 \rightarrow \text{RF} = 1.25$$

$$P \leq 16 \rightarrow \text{RF} = 1$$

COR : Correction

$$L < 20.0 \quad \rightarrow \text{COR} = 3$$

$$20.0 \leq L < 21.0 \quad \rightarrow \text{COR} = 2$$

$$21.0 \leq L < 22.0 \quad \rightarrow \text{COR} = 1$$

$$22.0 \leq L < 24.5 \quad \rightarrow \text{COR} = 0$$

$$24.5 \leq L \quad \rightarrow \text{COR} = -0.5$$

4.1.2 SRK/T formula

1. Implanted IOL power (D) for emmetropization

$$P_{emmet} = \frac{1000 \, na \cdot X}{(L1 - C1)Y}$$

2. Implanted IOL power (D) for ametropia

$$P_{amet} = \frac{1000 \, na \{X - 0.001 \, REF(V \cdot X + L1 \cdot r)\}}{(L1 - C1)\{Y - 0.001 \, REF(V \cdot Y + C1 \cdot r)\}}$$

3. Estimated refractive power after surgery (D)

$$REF_{iol} = \frac{1000 \, na \cdot X - P \cdot Y(L1 - C1)}{na(V \cdot X + L1 \cdot r) - 0.001 P(L1 - C1)(V \cdot Y + C1 \cdot r)}$$

Where:

$$X = na \cdot r - L1(nc - 1)$$

$$Y = na \cdot r - C1(nc - 1)$$

L1 : Visual axial length (mm)

$$= L + (0.65696 - 0.02029L)$$

L : Axial length (mm)

REF : Desired refractive power after surgery (D)

r : Radius of corneal curvature (mm)

$$= 337.5/K$$

W : Calculated corneal diameter (mm)

$$= -5.41 + 0.58412LC + 0.098K$$

LC : Corrected axial length (mm)

$$L \leq 24.2 \rightarrow LC=L$$

$$L > 24.2 \rightarrow LC = -3.446 + 1.716L - 0.0237L^2$$

C1 : Estimated anterior chamber depth after surgery (mm)

$$= H + \text{Ofst.}$$

Ofst: Calculated distance from the iris surface to the optical surface of the implanted IOL (including corneal thickness) (mm)

$$= \text{ACD const} - 3.336$$

$$= (0.62467A - 68.747) - 3.336$$

H : Height of corneal dome (mm)

$$= r - \sqrt{r^2 - W^2 / 4}$$

A : A-Constant

K : Average corneal refractive power (D)

$$= (K1 + K2)/2$$

P : Implanted IOL power (D)

V : Vertex distance (mm)

$$= 12$$

na : Aqueous humor and vitreous refractive index

$$= 1.336$$

nc : Corneal reflective index

$$= 1.333$$

4. Personal A - Constant

$$A = \left(-b + \sqrt{b^2 - 4ac} \right) / 2a$$

Where:

$$a : 0.62467^2 \alpha$$

$$b : 0.62467 \{ 2\alpha(H - 72.083) + \beta \}$$

$$c : \alpha(H - 72.083)^2 + \beta(H - 72.083) + \gamma$$

$$\alpha : P(1 - nc) + 0.001P \cdot \text{AREF} \{ V(nc - 1) - r \}$$

$$\beta : P \{ na \cdot r + L1(nc - 1) + 0.001 \text{AREF} \{ L1 \cdot r + V \cdot L1(1 - nc) - na \cdot V \cdot r \} \}$$

$$\gamma : na \{ 1000X - P \cdot L1 \cdot r + \text{AREF} \{ 0.001P \cdot V \cdot L1 \cdot r - (V \cdot X + L1 \cdot r) \} \}$$

AREF : Refractive power of eye after surgery (D)

4.1.3 HOLLADAY formula

1. Implanted IOL power (D)

$$P = \frac{1000 na \{X - 0.001 REF (V \cdot X + L2 \cdot r)\}}{(L2 - C2 - SF) [Y - 0.001 REF \{V \cdot Y + r(C2 + SF)\}]}$$

2. Predicted refractive power after surgery (D)

$$REF_{iol} = \frac{1000 na \cdot X - P \cdot Q \cdot Y}{na(V \cdot X + L2 \cdot r) - 0.001 P \cdot Q \{V \cdot Y + r(C2 + SF)\}}$$

Where

X : $na \cdot r - L2(nc - 1)$

Y : $na \cdot r - (nc - 1)(C2 + SF)$

Q : $L2 - C2 - SF$

na : Aqueous humor and vitreous refractive index
= 1.336

nc : Corneal reflective index
= 4/3

L : Axial length (mm)

r: Radius of corneal curvature (mm)
= 337.5 / K

K : Average corneal refractive power (D)
= (K1 + K2)/2

SF : Distance from the iris surface to the optical center of the implanted IOL (mm)

REF : Desired refractive power after surgery (D)

V : Vertex distance (mm)
= 12

P : Implanted IOL power (D)

L2 : Corrected axial length (mm)
= L + 0.2

C2 : Anatomic anterior chamber depth; distance from the corneal vertex to the iris surface (mm)

$$= 0.56 + R_{ag} - \sqrt{R_{ag}^2 - AG^2 / 4}$$

$$r < 7 \quad \rightarrow R_{ag} = 7$$

$$r \geq 7 \quad \rightarrow R_{ag} = r$$

$$AG = 12.5L / 23.45$$

$$AG > 13.5 \quad \rightarrow AG = 13.5$$

3. Personal SF

$$SF = \{-BQ - \sqrt{BQ^2 - 4AQ \cdot CQ}\} / (2AQ) - C2$$

Where

$$AQ = (nc-1) - 0.001AREF\{V(nc-1) - r\}$$

$$BQ = 0.001AREF\{L2 \cdot V(nc-1) - r(L2 - V \cdot na)\} - \{L2(nc-1) + na \cdot r\}$$

$$CQ1 = 0.001AREF[V\{na \cdot r - L2(nc-1)\} + L2 \cdot r]$$

$$CQ2 = 1000na\{na \cdot r - L2(nc-1) - CQ1\} / P$$

$$CQ3 = L2 \cdot na \cdot r - 0.001AREF \cdot L2 \cdot V \cdot r \cdot na$$

$$CQ = CQ3 - CQ2$$

AREF : Refractive power of eye after surgery (D)

4. Corresponding SF

$$SF = 0.5663A - 65.60$$

Where

A : A-Constant

4.1.4 Hoffer Q formula

1. Implanted IOL power (D)

$$P = \frac{1336}{L - C - 0.05} - \frac{1.336}{\frac{1.336}{K + R} - \frac{C + 0.05}{1000}}$$

Where

$$R = \frac{Rx}{1 - 0.012Rx}$$

2. Desired refractive power after surgery (D) when wearing glasses

$$Rx = \frac{R}{1 + 0.012R}$$

Where

$$R = \frac{1.336}{\frac{1.336}{\frac{1336}{L - C - 0.05} - P} + \frac{C + 0.05}{1000}} - K$$

C : Predicted anterior chamber depth after surgery (ACD)

$$= X + Y$$

Where

$$X = C1 + 0.3 \times (L - 23.5) + (\tan K)^2$$

$$Y = 0.1M \times (23.5 - L)^2 \times \tan\{0.1(G - L)^2\} - 0.99166$$

$$L \leq 23.0 \rightarrow M = +1, G = 28$$

$$L > 23.0 \rightarrow M = -1, G = 23.5$$

$$L > 31.0 \rightarrow L = 31$$

$$L < 18.5 \rightarrow L = 18.5$$

P : Implanted IOL power (D)

L : Axial length (mm)

C1 : Personal anterior chamber depth (mm)

K : Average corneal refractive power (D)

$$= (K1 + K2)/2$$

Rx : Desired refractive power after surgery (D)

3. Personal ACD

$$ACD = \frac{L + N - \sqrt{(L - N)^2 + \frac{4 \cdot 1336(N - L)}{P}}}{2} - 0.05$$

Where

$$N = \frac{1336}{K + R} \quad R = \frac{AREF}{1 - 0.012AREF}$$

AREF : Refractive power of eye after surgery (D)

4.1.5 HAIGIS standard formula

1. Implanted IOL power (D)

$$P = \frac{1000na}{L - d} - \frac{na}{\frac{z}{1000} - \frac{d}{1000}}$$

Where

$$Z = DC + \frac{REF}{1 - \frac{REF \cdot V}{1000}}$$

$$d = a_0 + a_1 \cdot ACD + a_2 \cdot L \quad (ACD \neq 0)$$

$$d = (a_0 - 0.241 \cdot a_1) + (a_2 + 0.139 \cdot a_1)L \quad (ACD = 0)$$

$$a_0 = 0.62467A - 72.434 DC = \frac{1000(nc - 1)}{RC}$$

2. Estimated refractive power after surgery (D)

$$REF_{iol} = \frac{1000(1000Y - DC \cdot X)}{V(1000Y - DC \cdot X) + 1000X}$$

Where

$$X = d^2 \cdot P + 1000L \cdot na - d \cdot L \cdot P$$

$$Y = na(1000 \cdot na - L \cdot P + d \cdot P)$$

na : Aqueous humor and vitreous refractive index
= 1.336

nc : Corneal reflective index

$$= 1.3315$$

A : A-Constant

RC: Average radius of corneal curvature (mm)

$$= (r1 + r2)/2$$

DC: Average corneal refractive power (D)

L : Axial length

ACD : Anterior chamber depth (mm)

REF : Desired refractive power after surgery (D)

V : Vertex distance (mm)

$$= 12$$

P : Implanted IOL power (D)

a1 : 0.4 a2 : 0.1

* a1 and a2 are default values.

3. Personal A-Constant

$$A = \frac{d - a1 \cdot ACD - a2 \cdot L + 72.434}{0.62467} \quad (ACD \neq 0)$$

$$A = \frac{d - L(a2 + 0.139 \cdot a1) + 0.241 \cdot a1 + 72.434}{0.62467}$$

(ACD = 0)

Where

$$d = \frac{P(L \cdot z + 1000na) - \sqrt{P^2(L \cdot z + 1000na)^2 - 4P \cdot z(1000L \cdot na \cdot z + 1000L \cdot na \cdot P - 1000^2 \cdot na^2)}}{2P \cdot z}$$

$$Z = DC + \frac{AREF}{1 - \frac{AREF \cdot V}{1000}}$$

$$DC = \frac{1000(nc - 1)}{r}$$

AREF : Refractive power of eye after surgery (D)

4.2 How to calculate axial length using the axial length measurement function

4.2.1 Phakic eye

The axial length measurement is obtained using the following formulae.

<When using the average acoustic velocity>

$$L = \frac{V \cdot t}{2}$$

L: Axial length measurement
V: Average acoustic velocity for axial length
t: Measurement time

<When using the divisional acoustic velocity>

$$L = \frac{V_{acd} \cdot t_{acd}}{2} + \frac{V_{Ins} \cdot t_{Ins}}{2} + \frac{V_{vit} \cdot t_{vit}}{2}$$

L : Axial length measurement
 V_{acd} : Anterior chamber depth acoustic velocity
 V_{Ins} : Crystal lens acoustic velocity
 V_{vit} : Vitreous acoustic velocity
 t_{acd} : Time for measuring anterior chamber depth
 t_{Ins} : Time for measuring crystal lens
 t_{vit} : Time for measuring a vitreous

4.2.2 Dense cataract eye

Take the axial length measurement in the same manner as when using the average acoustic velocity for a phakic eye.

4.2.3 Aphakic eye

Take the axial length measurement in the same manner as when using the average acoustic velocity for a phakic eye.

4.2.4 IOL eye

[Default setting for acoustic velocity at delivery
(changeable)]

- IOL acoustic velocity (reference)

Acrylic: 2,200 m/s

Silicone: 1,049 m/s

PMMA: 2,718 m/s

* The acoustic velocity varies depending on materials, makers, and temperature.

- Vitreous acoustic velocity: 1,532 m/s

- Anterior chamber depth acoustic velocity:
1,532 m/s

The axial length measurement is obtained using the following formulae.

$$Lp = \frac{V_{acd} \cdot t_{acd}}{2} + Th + \frac{V_{vit} \cdot t_{vit}}{2}$$

$$t_{vit} = t_{axl} - t_{acd} - \frac{2Th}{V_{IOL}}$$

Lp : Axial length measurement

Th : Center thickness of IOL (entered by user)

V_{IOL} : IOL acoustic velocity

V_{acd} : Anterior chamber depth acoustic velocity

V_{vit} : Vitreous acoustic velocity

t_{axl} : Measurement time

t_{acd} : Time for measuring anterior chamber depth

t_{vit} : Time for measuring a vitreous

4.3 Amplifier characteristics of the A-scan diagnosis

The I/O characteristics of the log amplifier, linear amplifier, and S-curve amplifier selected for the A-scan diagnosis are as shown below.

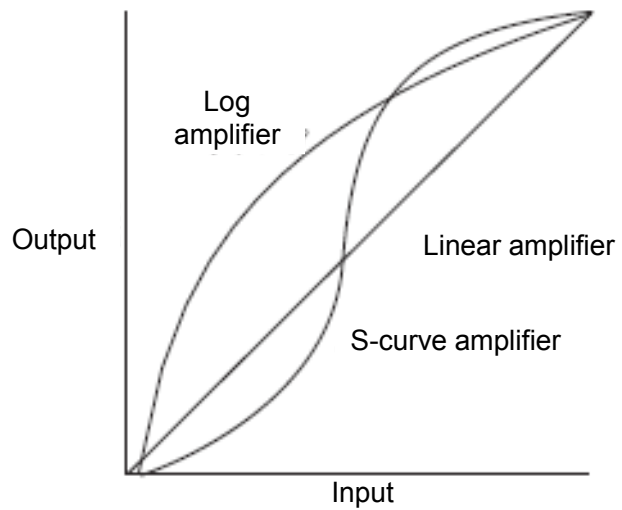

4.4 Checking the software version

Refer to “3.7.2 g) Version Information.”

4.5 Ultrasound wave output

4.5.1 MI (mechanical index)

MI is a parameter that indicates the mechanical effects of ultrasound waves on biological tissue ultrasound.

Mechanical effects are, for example, movement (or flow) around air bubbles compressed when an acoustic pressure wave of the ultrasound wave passes through biological tissue, or energy released when cavitation temporarily bursts the air bubbles.

4.5.2 TIS (thermal index of soft tissue)

TIS is a parameter that indicates the thermal effects of ultrasound waves on biological tissue ultrasound.

Thermal effects mean an increase in the tissue temperature due to emission of ultrasound waves.

5. INSPECTION AND MAINTENANCE

5.1 Warranty

One-Year Limited Warranty

The seller guarantees this product to be free from defects in material and workmanship under the normal use of this product for one (1) year or other term complying with local regulations from the date of invoice issued by Seller to the original purchaser.

Lamps, paper and other consumable items shall not be covered by this warranty.

This warranty also shall NOT apply if the product has not been installed, operated or maintained in accordance with the INSTRUCTION MANUAL of Tomey Corporation (here in after called "Tomey"). Neither seller nor Tomey shall be liable for any damages caused by purchaser's failure to follow instruction for proper installation, use and maintenance of product.

This warranty is only applicable to the new product and DOES NOT cover any damage resulting from or caused by accident or negligence, abuse, misuse, mishandling, improper modification of this product, by persons other than personnel duly authorized by Tomey, not to a product whose serial number or batch number is removed, altered or effaced.

THIS WARRANTY IS EXPRESSLY IN LIEU OF ANY AND ALL OTHER WARRANTIES, EXPRESSED OR IMPLIED (INCLUDING SPECIFICALLY, WITHOUT LIMITING THE GENERALITY OF THE FOREGOING, ALL WARRANTIES OF MERCHANTABILITY AND FITNESS FOR A PARTICULAR PURPOSE), AND ALL OTHER OBLIGATION AND LIABILITY ON THE PART OF SELLER AND TOMEY. NEITHER SELLER NOR TOMEY SHALL BE LIABLE FOR INCIDENTAL, CONSEQUENTIAL OR SPECIAL DAMAGES UNDER ANY CIRCUMSTANCES OR FOR MORE THAN REPAIR, REPLACEMENT OR REFUND OF THE PURCHASE PRICE OF DEFECTIVE GOODS.

5.2 Durable years

This instrument is designed to be remain durable for 8 years when operated under the appropriate environment and adequately inspected and serviced.

5.3 Inspection

- Note** ■ *When there is a problem, waveforms may not be obtained correctly. Contact Tomey or our local distributor immediately for repair or replacement.*
- *Wipe the exterior of the instrument with a soft cloth dampened with diluted neutral detergent before transferring the instrument to Tomey Corporation for maintenance and inspection. Sterilize the measurement probes as described in 5.4.1 c) before returning them.*
- *Be sure to hold the connector when removing the measurement probe from the main unit. Holding and pulling the cord may damage the inner core wires.*

Check that the contact section of the measurement probe is not damaged. Check that the connector is firmly inserted and the cable is not damaged.

5.4 Routine maintenance



- *Hold the plug when disconnecting the power cord from the outlet to avoid applying excessive force on the cord. Pulling the cord may damage the inner core wires, resulting in electric shock or fire.*
- Note** ■ *Do not use organic solvents such as thinner, benzene, or acetone to clean the instrument and accessories. These solvents may damage the surface of the instrument.*

5.4.1 Maintenance of measurement probes

Note ■ *Be sure to hold the connector when removing the probe from the main unit. Holding and pulling the cord may damage the inner core wires.*

■ *Attach the protective cap and place the probe in the probe holder when the biometry probe, pachy probe, and A-scan diagnosis probe are not used.*

a) Appearance check

- Check that the contact section of the probe is not damaged.
- Check that the connector is firmly inserted and the cable is not damaged.

b) Cleaning

Note ■ *Use absorbent cotton to clean the contact section of the measurement probe. Otherwise, the contact section may be damaged.*

■ *Holding and pulling the cord may damage the inner core wires.*

■ *Do not clean the connecting section of the connector.*

- When cleaning the main body of measurement probe, wipe it with absorbent cotton dampened with antiseptic soap and water or alcohol, and then with cotton dampened with water.
- When cleaning the tip of the measurement probe, wipe it with absorbent cotton dampened with alcohol, and then with cotton dampened with water.
- Wipe cords with a well wrung cloth dampened with water.
- Completely remove water after cleaning.

c) Sterilization

Note ■ *Effective chemicals vary depending on the types of germs and viruses. Select appropriate chemicals and immersion time based on the guidelines, articles, literature, etc. provided by local administrative organizations and/or societies.*

■ *Follow the described EOG sterilizing conditions. Otherwise, safe sterilization cannot be assured.*

■ *Do not use EOG sterilizer for the biometry probe and A-scan diagnosis probe.*

■ *A high-pressure steam sterilizer is acceptable only for the immersion attachment.*

- The biometry probe, pachymetry probe, and A-scan diagnosis probe can be sterilized by wiping or immersing the section within 10 mm from the contact section using the following chemicals. Thoroughly rinse the probe with purified water and thoroughly dry it after sterilization.

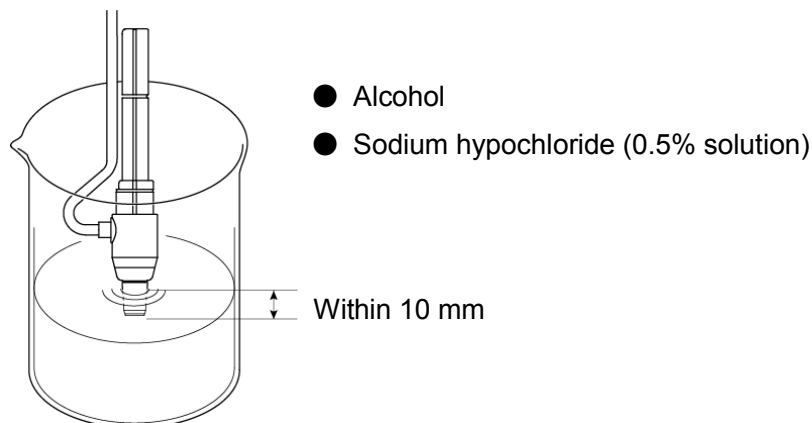

- Immerse the whole immersion attachment and disposable tip in alcohol or sodium hypochloride solution (0.5%), rinse them with purified water to completely remove chemicals, and thoroughly dry them.

-
- When sterilizing the pachymetry probe with EOG, remove the protective cap from the tip of the probe and put the whole probe in a sterilizing pack.

<Sterilization conditions>

EOG: Mixture of ethylene oxide gas (20%) and carbonic acid gas (80%)

Sterilizing temperature: $50 \pm 5^{\circ}\text{C}$

Sterilizing pressure: $(9.8 \pm 0.98) \times 10^4 \text{ Pa}$

Sterilizing time: 5 +/-1 hours

Aeration time:

Corneal thickness probe: 10 hours or more (continuous)

Immersion attachment: 10 hours or more (continuous)

Disposable tip: 20 cycles of 30 minutes (supply air for ventilation after each cycle)

- * Use the probe after leaving for at least 7 hours, and the disposable tip for at least 6 days, after completing sterilizing with EOG.

5.4.2 Cleaning and Disinfection of measurement probes (for Europe)

[Specific Section for European continent]

Note ■ *Follow the legal requirements and regulation in the country.*

■ *Refer to the instruction manual concerning test-fluid for detail.*

a) Cleaning

Note ■ *Holding and pulling the cord may damage the inner core wires.*

■ *Do not clean the connecting section of the connector.*

- When cleaning the main body of the measurement probe and, wipe it with a suitable fluid eg. “Cleanisept® Wipes” and then wipe with cotton dampened with water
- Wipe the cord with a well wrung cloth dampened with water and remove water after cleaning.

b) Disinfection

Note ■ *Effective chemicals vary depending on the types of germs and viruses. Select appropriate chemicals and immersion time based on the guidelines, articles, literature, etc. provided by local administrative organizations and/or societies.*

■ *A high-pressure steam sterilizer is acceptable only for the immersion attachment.*

-
- The Ultrasound probe (biometry probe, pachymetry probe, and A-scan diagnostic probe) can be disinfected by immersing the contact section of the probe tip in suitable cleaning fluids.

- Biometer / A-diagnostic probe/Pachy probe

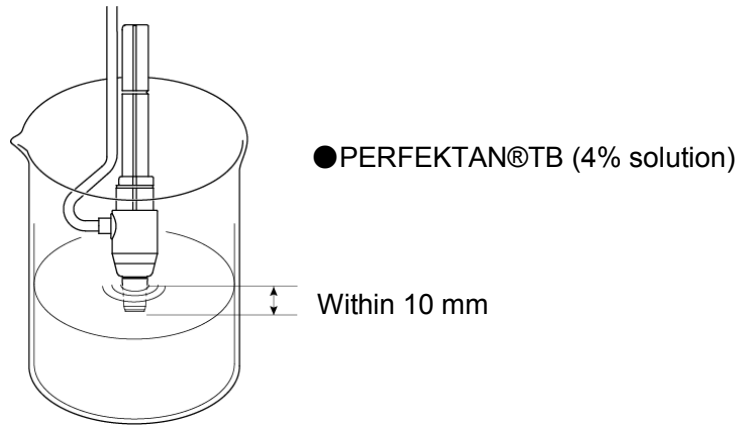

One clinically tested cleaning product would be:

- PERFEKTAN®TB

(4% concentration and an exposure times of 30 min)

Antimicrobial Properties Perfektan® TB is:

- bactericidal (incl. MRSA=multi resistant Staphylococcus aureus)
- tuberculocidal
- fungicidal (C. albicans), levurocidal
- virus inactivating incl. HBV/HIV/BVDV/HCV/Papova
- Polyoma/Adeno virus - sporicidal

Thoroughly rinse the probe with purified water and thoroughly dry it after cleaning.

5.4.3 Maintenance of main unit

- Note** ■ *Do not use organic solvents such as thinner to clean the main unit of the instrument. These solvents may damage the surface of the instrument.*
- *When disconnecting cords, do not apply excessive force on the cord; for example, do not hold and pull the cord to disconnect it.*
- *Do not touch the connection terminal surface of the main unit or measurement probe.*

- Wipe off dirt on the main unit by lightly rubbing with a well wrung cloth dampened with water and then with a dry cloth. When it is very dirty, clean it by lightly rubbing with a well wrung cloth dampened with diluted neutral detergent. Then, wipe it with a cloth dampened with water and then with a dry cloth.
- Wipe off dirt on the monitor screen with a dry cloth. When it is very dirty, clean it by lightly rubbing with a well wrung cloth dampened with diluted neutral detergent. Then, wipe it with a cloth dampened with water and then with a dry cloth.

- Note** ■ *Do not leave any water, chemicals, etc. remaining on the touch panel as the surface of the touch panel is vulnerable to moisture. The surface of the touch panel may be damaged and unable to maintain the appropriate performance.*

- Wipe off dirt on the surface of the touch panel with a dry soft cloth. When it is very dirty, lightly wipe it with a soft cloth dampened with alcohol. Further, wipe it with a dry soft cloth to completely remove moisture.

5.5 Replacing consumables

- Contact Tomey Corporation or our local distributor for replacement of the battery.

5.6 Storing



- *Install the instrument in a location free of water or chemicals. Any water or chemicals entering the instrument may cause an electric shock or failure.*



- *Do not store the instrument in a location where chemicals are stored or gases may occur. Spilt chemicals or vapor may enter the instrument and result in fire.*
- *Disconnect the power cord from the outlet to ensure safety when the instrument is not operation for 1 month or longer.*
- *Store the instrument in a location not subject to direct sunlight, high temperature and humidity, or air containing dust, salt and/or sulfur. Otherwise, failure or malfunction may occur.*
- *Store the instrument in a leveled stable place free of vibration or mechanical impact. Otherwise, measurement cannot be conducted correctly. The instrument may also topple over or fall down, resulting in fire or a fatal accident.*

- Clean and dry the measurement probe, attach the protective cap, and place it in the probe case for storage.
- When the instrument has not been used for a while, check that the instrument is operating correctly before starting operation again.

-
- The service life of battery may be affected when the instrument is stored in a hot place. Store the instrument under the following conditions.

Storage conditions

- Ambient temperature range: -20 – +40°C
- Relative humidity range: 45 – 85%

5.7 Disposal

- Note**
- *Keep the box and packing materials for use when moving or transporting the instrument.*
 - *Keep the packing materials and box together.*
 - *When disposing of the packing materials, sort them by type and abide by local government rules and regulations.*
 - *A lithium battery is used in the instrument. Handling of the lithium battery varies depending on governing bodies. Follow relevant laws and local rules and regulations, or contact our local distributor or Tomey Corporation.*

6. TROUBLESHOOTING

Check the following first when you encounter any problems. If the problem is not solved even after checking the applicable item listed below, contact our local distributor to request inspection and/or repair.



- **Do not remove the cover of the instrument. You may be directly exposed to high voltage sections.**



- **Do not take any actions other than those specified below.**

<Common items>

The power LED does not turn on when the power switch is turned on.

? Cause 1) Problem with the power plug

Solution ➡ Check that the power plug is firmly connected to the outlet. Check that the AC adapter is firmly connected to the main unit. Check that there is no flaws in the AC cord, such as cracks or tears.

? Cause 2) Problem with the power outlet

Solution ➡ Check that power is supplied to the outlet to which the power cord is connected.

Nothing appears on the monitor screen.

? Cause 1) The auto power off function, which automatically turns off the screen when the instrument is not operated for the specified time, has been activated.

Solution ➡ Touch the monitor screen.

? Cause 2 Built-in connection is established with UD-8000.

Solution ➡ Nothing appears on the monitor while connected to UD-8000. Disconnect AL-4000 from UD-8000.

A different button to the one touched on the touch panel becomes active.

? Cause 1 The touch panel is not calibrated correctly.

Solution ➡ Turn power on while pressing the MODE button on the front of the main unit to display the touch panel calibration screen. [+] appears on the screen. Touch the center. The point touched disappears and then the next [+] appears. Touch the center again. Repeat this step until [+] does not appear to complete calibration. Press the MODE button to return to the measurement screen. If this calibration of the touch panel problem occurs repeatedly during operation, contact our local distributor.

An error message “Connect the USB cable again” appears and measurement cannot be performed.

? Cause 1 The USB cable is disconnected.

Solution ➡ Connect the USB cable again. Communication is resumed and measurement can be started.

“Data remains on both devices and connection could not be established. Set either device to new patient mode and connect the devices again.” This error message appears and communication cannot be started.

? Cause 1 The patient information and measurement data is retained on both devices.

Solution ➡ Touch the “New” button on both or either device to delete the patient information and measurement data.

Wireless communication does not start even when power is turned on.

? Cause 1 The device to be connected is not turned on.

Solution ➡ Turn on the device to be connected.

? Cause 2 Settings for wireless communication are not set for this instrument.

Solution ➡ Set the wireless communication settings on the instrument, referring to “3.7.2 c) Wireless Communication Setting.”

? Cause 3 Settings for wireless communication are not set for the device to be connected.

Solution ➡ Set the wireless communication settings for the device to be connected.

The patient information cannot be entered or changed.

? Cause 1 The instrument is connected to another device.

Solution ➡ The patient information cannot be entered from the AL-4000 measurement unit while connected to another device. Cut the connection with the other device.

Cause 2 The measurement result has already been saved.

Solution ➡ The patient information cannot be changed after the data is saved.

<Axial length measurement function>

The axial length cannot be measured.

Cause 1 The biometry probe is not connected correctly.

Solution ➡ Connect the probe correctly until it is locked as described in “3.2.1 b) Connecting the biometry probe.”

Cause 2 The measurement conditions in immersion mode are not satisfied. (In the case of immersion mode)

Solution ➡ In immersion mode, data is captured when a corneal waveform is within 2.0 – 5.0 mm from the initial waveform. Place the corneal protective agent or immersion attachment between the corneal and the tip of the biometry probe to satisfy these conditions.

Cause 3 The biometry probe is directly applied to the corneal without using a corneal protective agent or immersion attachment. (In the case of immersion mode)

Solution ➡ Use the immersion attachment or corneal protective agent for measurement in immersion mode as described in “3.3.5 a) Handling the biometry probe in contact/immersion mode.” Perform measurement in contact mode when directly applying the biometry probe to the corneal.

Measurement cannot be performed in Auto mode.

? Cause 1 The mode is set to Manual.

Solution ➡ Set to auto measurement (Auto or Auto quick). (Refer to 3.3.2 Setting the axial length calculation method and converted acoustic velocity for the eye to be measured.”)

? Cause 2 Noise generated in the surrounding area.

Solution ➡ If there is any source of noise (devices such as a motor, laser surgical equipment, etc.) near the instrument, move it away from the instrument.

? Cause 3 Patient’s sight is unstable.

Solution ➡ Use the fixlight in the biometry probe or on the chin rest to guide the sight of the patient.

? Cause 4 The contact section of the biometry probe is damaged.

Solution ➡ If damaged, immediately stop measurement and contact our local distributor.

Measurement cannot be performed in Manual mode.

? Cause 1) The footswitch is not connected correctly.

Solution ➡ Connect the footswitch correctly until it is locked as described in “3.2.1 c) Connecting the footswitch.”

? Cause 2) The mode is set to auto measurement (Auto or Auto quick).

Solution ➡ Set to Manual mode. (Refer to “3.3.2 Setting the axial length calculation method and converted acoustic velocity for the eye to be measured.”)

Measurements are unstable or inappropriate.

? Cause 1) The biometry probe is not connected correctly.

Solution ➡ Connect the probe correctly until it is locked as described in “3.2.1 b) Connecting the biometry probe.”

? Cause 2) There is too much pressure on the corneal.

Solution ➡ When using the chin rest, ensure adequate length from the biometry probe to the cord hook so that the probe cord does not pull the slider of the chin rest. (Refer to “3.3.6 b) Handling the slider in chin-rest measurement mode.”)

? Cause 3) The retina gate cursor is not set in an appropriate position.

Solution ➡ Set the retina gate cursor on the immediate left of the actual retina waveform. Make sure that there are no

unnecessary waveforms between the retina gate cursor and retina waveform.

? Cause4 The biometry probe is not applied appropriately.

Solution ➡ Apply the probe to the center of the corneal perpendicularly so that the retina waveform spikes.

? Cause5 Too much corneal protective agent is applied. (In the case of contact mode)

Solution ➡ When too much corneal protective agent is applied, a gap is formed between the biometry probe and corneal, and the measurement result may tend to be longer. Apply appropriate amount of corneal protective agent.

? Cause6 The immersion attachment is used. Or, a large amount of corneal protective agent is applied. (In the case of contact mode)

Solution ➡ The measurement result tends to be longer only by the thickness of corneal protective agent. Complete settings in immersion mode and contact mode correctly, and take measurements as described in “3.3.5 a) Handling the biometry probe in contact/immersion mode.”

? Cause7 The biometry probe is directly applied to the corneal without using the corneal protective agent. (In the case of immersion mode)

Solution ➡ Use the immersion attachment or corneal protective agent for

measurement in immersion mode as described in “3.3.5 a) Handling the biometry probe in contact/immersion mode.” Perform measurement in contact mode when directly applying the biometry probe to the corneal.

? Cause 8) The converted acoustic velocity is not set appropriately.

Solution ➡ Check the setting of the converted acoustic velocity. A different converted acoustic velocity can be set for right and left eyes. Check the setting for both eyes. (Refer to “3.3.2 Setting the axial length calculation method and converted acoustic velocity for the eye to be measured.”)

? Cause 9) The contact section of the biometry probe is damaged.

Solution ➡ If damaged, immediately stop measurement and contact our local distributor.

Monitoring sound does not stop. Data is captured even while the probe does not contact the eyeball.

? Cause 1) The tip of the biometry probe is wet.

Solution ➡ Remove drops of water.

Monitoring sound does not go off.

? Cause 1) The volume is set to level 0 or “Mute.”

Solution ➡ Set the volume to a level other than “0” or “Mute” as described in “3.7.2 a)

Common Setting.”

Noise interferes with waveforms.

? Cause 1 The biometry probe is not connected correctly.

Solution ➡ Connect the probe correctly until it is locked as described in “3.2.1 b) Connecting the biometry probe.”

? Cause 2 Noise is generated in the surrounding area.

Solution ➡ If there is any source of noise (devices such as a motor, laser surgical equipment, etc.) near the instrument, move it away from the instrument.

The probe error confirmation screen appears when the power is turned on.

? Cause 1 The biometry probe is not connected correctly.

Solution ➡ Connect the probe correctly until it is locked as described in “3.2.1 b) Connecting the biometry probe.”

The fixlight in the biometry probe is turned off.

? Cause 1 Lighting of the fixlight is set to “OFF.”

Solution ➡ Set to ON as described in “3.7.2 d) Eye Axis Setting.”

<Pachymetry function>

The probe error confirmation screen appears when the power is turned on or the pachymetry probe is calibrated.

? Cause 1 The pachymetry probe is not connected correctly.

Solution ➡ Connect the probe correctly until it is locked as described in “3.2.1 d) Connecting the corneal thickness/A-scan diagnosis probe.”
Touch the “Calib” button on the measurement screen or restart the instrument to calibrate the pachymetry probe after connecting the probe.

Measurement cannot be performed.

? Cause 1 The pachymetry probe is not connected correctly.

Solution ➡ Connect the probe correctly until it is locked as described in “3.2.1 d) Connecting the corneal thickness/A-scan diagnosis probe.”

The error message “Out of range!” appears and measurement cannot be performed.

? Cause 1 The measurement range setting is not correct.

Solution ➡ Touch the “Meas Range” button to set the measurement range appropriately.

Stable measurements cannot be obtained. Appropriate measurements cannot be obtained.

? Cause 1 The pachymetry probe is not connected correctly.

Solution ➡ Connect the probe correctly until it is locked as described in “3.2.1 d) Connecting the corneal thickness/A-scan diagnosis probe.”

? Cause 2 The pachymetry probe is not applied appropriately.

Solution ➡ Apply the pachymetry probe perpendicular to the corneal at the position to be measured.

? Cause 3 The converted acoustic velocity is not set appropriately.

Solution ➡ Check that the converted acoustic velocity is set correctly. (Refer to “3.5.3 Setting how to display the conversion sound velocity and bias value.”)

? Cause 4 The contact section of the pachymetry probe is damaged.

Solution ➡ If damaged, immediately stop measurement and contact our local distributor.

? Cause 5 The pachymetry probe is not calibrated correctly.

Solution ➡ Thoroughly wipe the tip of the pachymetry probe and press the sensitivity calibration button to re-calibrate the probe.

Measurement cannot be performed in Auto mode.

? Cause 1) The pachymetry probe is not calibrated correctly.

Solution ➡ Thoroughly wipe the tip of the pachymetry probe and press the sensitivity calibration button to re-calibrate the probe.

? Cause 2) Noise is generated in the surrounding area.

Solution ➡ If there is any source of noise (devices such as a motor, laser surgical equipment, etc.) near the instrument, move it away from the instrument.

? Cause 3) The contact section of the pachymetry probe is damaged.

Solution ➡ If damaged, immediately stop measurement and contact our local distributor.

? Cause 4) The measurement mode is set to Manual.

Solution ➡ Switch the mode to auto measurement mode.

The measurable point does not move immediately when the pachymetry probe is removed from the corneal.

? Cause 1) The tip of the pachymetry probe is wet.

Solution ➡ Thoroughly remove any drops of water.

Monitoring sound does not stop. Data is captured even while the probe does not contact with the eyeball.

? Cause 1 The tip of the pachymetry probe is wet.

Solution ➡ Thoroughly remove any drops of water.

<A-scan diagnosis>

The mode-A waveform is not displayed.

? Cause 1 The A-scan diagnosis probe is not connected correctly.

Solution ➡ Check that the A-scan diagnosis probe is connected until its connector is locked.

? Cause 2 There is no corneal protective agent applied or the amount is too small.

Solution ➡ Apply the appropriate amount of corneal protective agent to the tip of the A-scan diagnosis probe. If the problem is not solved even after the protective agent is applied, apply more.

The mode-A waveform is disarranged.

? Cause 1 Noise is generated in the surrounding area

Solution ➡ If there is any source of noise (devices such as a motor, laser surgical equipment, etc.) near the instrument, move it away from the instrument.

The function to display the saved data is not available.

? Cause 1 Data is not saved in the internal memory.

Solution After the waveform data is saved in the internal memory by the function to save data in the internal memory.

The probe error confirmation screen appears when switching to the A-scan diagnosis.

? Cause 1 The A-scan diagnosis probe is not connected correctly.

Solution Check that the A-scan diagnosis probe is firmly connected.

<Related to data saving>

Data cannot be saved in the internal memory.

? Cause 1 The ID is not entered.

Solution The instrument uses the ID as a file name. Enter the ID and then save the data.

? Cause 2 There is not enough space available in the internal memory. (The confirmation screen appears when attempting to save the data.)

Solution Delete unnecessary data in the internal memory and save the data again.

7. SPARE PARTS AND OPTIONAL PARTS

The following spare parts and accessories are available from our local distributor of this instrument.

Contact our local distributor to order them.

7.1 Spare parts

- Immersion attachment

Specify the part type as “AL-4000 immersion attachment.”

7.2 Optional parts

- Pachymetry probe (with case and test piece)

Specify the part type as “AL-4000 pachy probe.”

- A-scan diagnosis probe

Specify the part type as “AL-4000 A-scan diagnosis probe.”

- Chin rest AL-1100

Specify the part type as “AL-4000 chin rest.”



This page is intentionally blank

8. SPECIFICATIONS

8.1 Specifications

8.1.1 Biometry/IOL power calculations

- Measurement range
 - Axial length : 13.00 to 45.00mm
 - ACD : 1.50 to 7.00mm
 - Lens thickness : 2.00 to 6.00mm

- Accuracy
 - Measurement Accuracy : ± 0.1 mm
 - Measurement Resolution : 0.01mm

- Factory setting of the converted velocity
 - Average velocity of the axial length
 - Phakic Eye : 1,550m/s
 - Dense Cataract : 1,548m/s
 - Aphakic : 1,532m/s
 - Lens velocity
 - Phakic Eye : 1,641m/s
 - Dense Cataract : 1,629m/s
 - ACD velocity
 - Phakic Eye : 1,532m/s
 - Dense Cataract : 1,532m/s
 - IOL Eye : 1,532m/s
 - Velocity of vitreous
 - Phakic eye : 1,532m/s
 - (In case of sectional velocity)
 - IOL Eye : 1,532m/s
 - IOL velocity
 - Acrylic : 2,200m/s
 - Silicone : 1,049m/s
 - PMMA : 2,718m/s
 - User : 2,200m/s

■ IOL thickness	
Acrylic	: 0.80mm
Silicone	: 1.00mm
PMMA	: 0.80mm
User	: 0.80mm

- IOL power calculation

- SRK II
- SRK/T
- HOLLADAY
- Hoffer Q
- HAIGIS Standard

- Biometry probe

- Type : Solid state
- Fixlight : Built in the probe, Red LED
- Transducer frequency : 10MHz
- Tip diameter : 6.0mmφ(concave)
- Dimension/Weight : 14.0mmφ×98mm/40g

8.1.2 Function of pachymetry

- Measurement range : 150 to 1,500μm

- Accuracy

- Measurement accuracy : ±5μm
- Measurement resolution : 1μm

- Percent bias/plus minus bias setting range

- Percent bias : 60 to 130%
- Plus minus bias : -600 to +450μm

- Factory setting and setting range of the converted velocity

: 1,640m/s / 1,400 to 2,000m/s

- Pachymetry probe

- Type : Solid state

■ Transducer frequency	: 20MHz
■ Tip diameter	: 1.5mmφ with an angle of 45°(flat)
■ Dimension/Weight	: 8.8mmφ×90mm/30g

8.1.3 A-scan Diagnosis

● Display Range	
■ Line analysis	: 64mm
■ Point analysis	: 45mm
● A-Scan diagnostic probe	
■ type	: Solid state
■ Transducer frequency	: 10MHz
■ Tip diameter	: 5mmφ(flat)
■ Dimension/Weight	: 8mmφ×97mm/30g

8.1.4 Main unit

● TFT LCD	: 3.5 inch color
● Dimension/Weight	: 109(W)×52(D)×166(H) 470g

With AC adapter

● Voltage	: 100-120/220-240 VAC
● Frequency	: 50/60Hz
● Power consumption	: 18/24 VA

Using built-in battery

● Voltage	: DC 3.7V
-----------	-----------

8.1.5 AC adapter

● Manufacturer	: SINPRO ELECTRONICS CO., LTD
● MODEL No.	: MPU16B-104-P25E001

8.1.6 Battery

● Battery	: Lithium ion battery
● Voltage	: DC 3.7V
● Manufacturer	: SANYO ELECTRIC CO., LTD.
● MODEL	: 1UF603443S

8.2 Energy and other consumption

8.2.1 Influences of ultrasound energy on the human body



This unit is exclusively designed for ophthalmic use, so do not use the instrument for any purposes other than ophthalmic use.

This unit is exclusively designed for ophthalmic biometry and pachymetry purposes.

The unit is set with a very weak ultrasound energy appropriate for ophthalmic use; however, minimize the duration of measurement and give minute caution not to cause the Patient to be exposed and with ultrasound energy while measurement.

8.2.2 Ultrasound energy

Acoustic Output Reporting Table(FDA)

Application(s):Biometry

Acoustic Output		MI	Ispta.3 (mW/cm2)	Isppa.3 (W/cm2)
Pre-Amendment Maximum Acoustic Output		0.23	17	28
Global Maximum Value		0.173	1.599	8.738
Associated Acoustic Parameter	pr.3(Mpa)		0.548	
	W0(mW)			0.0133
	fc(MHz)		10.09	10.09
	Zsp(cm)		1.83	1.83
	Beam dimensions	x-6(cm)		0.161
		y-6(cm)		0.159
	PD(usec)		0.153	
	PRF(Hz)		1200	
	EB D	Az.(cm)		0.54
		Ele.(cm)		0.54

Application(s):Pachymetry

Acoustic Output		MI	Ispta.3 (mW/cm ²)	Isppa.3 (W/cm ²)
Pre-Amendment Maximum Acoustic Output		0.23	17	28
Global Maximum Value		0.205	11.019	13.276
Associated Acoustic Parameter	pr.3(Mpa)		0.862	
	W0(mW)			0.0332
	fc(MHz)		17.765	17.765
	Zsp(cm)		0.05	0.05
	Beam dimensions	x-6(cm)		0.072
		y-6(cm)		0.072
	PD(usec)		0.104	0.104
	PRF(Hz)		8000	8000
	EB	Az.(cm)		0.19
D	Ele.(cm)		0.18	

Application(s):A-Scan

Acoustic Output		MI	Ispta.3 (mW/cm ²)	Isppa.3 (W/cm ²)
Pre-Amendment Maximum Acoustic Output		0.23	17	28
Global Maximum Value		0.0750	0.0127	1.747
Associated Acoustic Parameter	pr.3(Mpa)		0.242	
	W0(mW)			0.000517
	fc(MHz)		10.44	10.44
	Zsp(cm)		2.149	2.149
	Beam dimensions	x-6(cm)		0.30
		y-6(cm)		0.24
	PD(usec)		0.2425	0.2425
	PRF(Hz)		30	30
	EB	Az.(cm)		0.4
D	Ele.(cm)		0.4	

MI:	the Mechanical index
Ispta.3:	the derated spatial-peak temporal-average intensity
Isppa.3:	the derated spatial-peak pulse-average intensity
Pr.3	the derated peak rarefactional pressure
W0:	the ultrasonic power
fc:	the center frequency
Zsp:	the axial distance at which the reported parameter is measured
x-6,y-6:	are respectively the in-plane(azimuthal) and out of plane(elevational) -6dB dimensions in the x-y plane where Zsp is found
PD:	the pulse duration
PRF:	the pulse repetition frequency
EBD:	the entrance beam dimensions for the azimuthal and elevational planes

Acoustic Output Report (IEC60601-2-37)

Index label		MI			TIS Non-Scan($A_{aprt} \leq 1 \text{ cm}^2$)		
		Bio	Pachy	A-Diag	Bio	Pachy	A-Diag
Maximum index value		0.173	0.205	0.0750	0.00228	0.00299	0.000121
Associated acoustic parameters	pr, α [Mpa]	0.548	0.862	0.242			
	P[mW]				0.0474	0.0353	0.00243
	Min.of [$P\alpha(zs), I\alpha, \alpha(zs)$]						
	Zs						
	Zbp						
	Zb						
	Z at max.lpi, α [cm]	1.83	0.05	2.149			
	deq(zb)						
	fawf[MHz]	10.09	17.765	10.44	10.09	17.765	10.44
	Dim of Aaprt [cm]	X				0.54	0.19
Y					0.54	0.18	0.4
Other information	Td[us]	0.153	0.104	0.2425			
	Prr[Hz]	1200	8000	30			
	Pr at max.lpi[MPa]	1.037	0.889	0.525			
	deq at max.lpi						
	lpa, α at max.MI [W/cm ²]	8.738	13.276	1.747			
Operating Control conditions	Control						

α :	ACOUSTIC ATTENUATION COEFFICIENT
Aaprt:	-12dB OUTPUT BEAM AREA
Deq:	EQUIVALENT APERTURE DIAMETER
deq:	EQUIVALENT BEAM DIAMETER
fawf:	ACOUSTIC WORKING FREQUENCY
Ipa:	PULSE-AVERAGE INTENSITY
Ipa, α :	ATTENUATED PULSE-AVERAGE INTENSITY
Ipi:	PULSE-INTENSITY INTEGRAL
Ipi, α :	ATTENUATED PULSE-INTENSITY INTEGRAL
MI:	MECHANICAL INDEX
P:	OUTPUT POWER
P α :	ATTENUATED OUTPUT POWER
Pr:	PEAK-RAREFACTIONAL ACOUSTIC PRESSURE
Prr:	PULSE REPETITION RATE
TIS:	SOFT-TISSUE THERMAL INDEX
td:	PULSE DURATION
X,Y:	-12dB OUTPUT BEAM DIMENSIONS
z:	DISTANCE FROM THE SOURCE TO A SPECIFIED POINT
zb:	DEPTH FOR TIB
zbp:	BREAK-POINT DEPTH
zs:	DEPTH FOR TIS

8.3 Noise

The instrument makes monitoring sounds on these occasions.

- When turning the power on
- When self-diagnosing
- When using various keys
- When taking measurement(taking measurement data)
- When errors occur

8.4 Environment conditions

Use this unit under the environment conditions as followings

- Placeindoor without sunshine
- Temperature +10°C to +40°C
- Humidity 30 to 75%
- Pressure 700 to 1060hPa
- Power variation within ±10%

Store and transport this unit in the original packing box under the environment conditions as followings.

- Temperature -20°C to +50°C
- Humidity 45 to 85%
- Pressure 700 to 1060hPa

8.5 Classification of ME Equipment

Protection against electrical shock:

- Class II ME equipment (When using the AC adaptor)
- Internally powered ME equipment (When using the built-in battery)

Applied parts

- B applied parts (the tip of the biometry probe, the tip of the pachymetry probe and the tip of the A-scan diagnosis probe)

IP Code:

- IP20 (Main unit)
- IP21 (Foot switch)
- IP47 (the tip of biometry probe, the tip of the pachymetry probe and the tip of the A-scan diagnosis probe)
- IP41 (parts of the biometry probe, the pachymetry probe and the A-scan diagnosis probe except each tip and each connector.)

Mode of Operation:

- Continuous operation

8.6 Declaration of Conformity to EMC

<p>Caution: Medical electrical equipment. EMC (Electro Magnetic Compatibility) must be considered before any medical electrical equipment is installed or put into service. Follow the information in the accompanying documentation when installing and operating the AL-4000.</p>		
<p>Caution: Portable or mobile RF communication equipment can effect Medical Electrical equipment.</p>		
<p>Guidance and manufacturer's declaration - electromagnetic emissions</p>		<p>Table 201</p>
<p>The AL-4000 is intended for use in the electromagnetic environment specified below. The customer or the user of the AL-4000 should assure that it is used in such an environment.</p>		
Emissions test	Compliance	Electromagnetic environment - guidance
RF emissions CISPR 11	Group 1	The AL-4000 uses RF energy only for its internal function. Therefore, its RF emissions are very low and are not likely to cause any interference in nearby electronic equipment.
RF emission CISPR 11	Class B	The AL-4000 is suitable for use in all establishments, including domestic establishments and those directly connected to the public low voltage power supply network that supplies buildings used for domestic purposes.
Harmonic emissions IEC 61000-3-2	Class A	
Voltage fluctuation/ flicker emissions IEC 61000-3-3	Complies	

**Guidance and manufacturer's declaration -
electromagnetic immunity**

Table 202

The AL-4000 is intended for use in the electromagnetic environment specified below. The customer or the user of the AL-4000 should assure that it is used in such an environment.

Immunity test	IEC 60601 test level	Compliance level	Electromagnetic environment - guidance
Electrostatic Discharge(ESD) IEC 61000-4-2	± 6kV contact ± 8kV air	± 6kV contact ± 8kV air	Floors should be wood, concrete or ceramic tile. If floors are covered with synthetic material, the relative humidity should be at least 30%.
Electrical fast transient/ Burst IEC 61000-4-4	± 2kV for power supply lines ± 1kV for input/output lines	± 2kV for power supply lines ± 1kV for input/output lines	Mains power quality should be that of a typical commercial or hospital environment.
Surge IEC 61000-4-5	± 1kV line(s) to line(s) ± 2kV line(s) to earth	± 1kV line(s) to line(s) ± 2kV line(s) to earth	Mains power quality should be that of a typical commercial or hospital environment.
Voltage dips , short interruptions and voltage variations on power supply input lines IEC 61000-4-11	< 5 % UT (> 95 % dip in UT) for 0,5 cycle 40 % UT (60 % dip in UT) for 5 cycles 70 % UT (30 % dip in UT) for 25 cycles < 5 % UT (> 95 % dip in UT) for 5 sec	< 5 % UT (> 95 % dip in UT) for 0,5 cycle 40 % UT (60 % dip in UT) for 5 cycles 70 % UT (30 % dip in UT) for 25 cycles < 5 % UT (> 95 % dip in UT) for 5 sec	Mains power quality should be that of a typical commercial or hospital environment. If the user of the AL-4000 requires continued operation during power mains interruptions, it is recommended that the AL-4000 is powered from an uninterruptible power supply or a battery.
Power frequency (50/60 Hz) magnetic field IEC 61000-4-8	3 A/m	3 A/m	Power frequency magnetic fields should be at levels characteristic of a typical location in a typical commercial or hospital environment.

NOTE : UT is the a.c. mains voltage prior to application of the test level.

Guidance and manufacturer's declaration electromagnetic immunity

Table 204

The AL-4000 is intended for use in the electromagnetic environment specified below. The customer or the user of the AL-4000 should assure that it is used in such an environment.

Immunity test	IEC 60601 test level	Compliance level	Electromagnetic environment - guidance
Conducted RF IEC 61000-4-6	3 V rms 150kHz to 80MHz	3 V rms	Portable and mobile RF communication equipment should be used no closer to any part of the AL-4000, including cables, than the recommended separation distance calculated from the equation applicable to the frequency of the transmitter. Recommended separation distance $d = 1.2\sqrt{P}$ $d = 1.2\sqrt{P} \quad 80 \text{ MHz to } 800 \text{ MHz}$ $d = 2.3\sqrt{P} \quad 800 \text{ MHz to } 2.5 \text{ GHz}$ Where P is the maximum output power rating of the transmitter in watts (W) according to the transmitter manufacturer and d is the recommended separation distance in meters (m). Field strengths from fixed RF transmitters, as determined by an electromagnetic site survey, a should be less than the compliance level in each frequency range. B Interference may occur in the vicinity of equipment marked with the following symbol: 
Radiated RF IEC 61000-4-3	3 V/m 80MHz to 2,5GHz	3 V/m	

Note1 : At 80MHz and 800MHz, the higher frequency range applies.

Note2 : These guidelines may not apply in all situations. Electromagnetic propagation is affected by absorption and reflection from structures, objects and people.

a Field strengths from fixed transmitters, such as base stations for radio (cellular/cordless) telephones and land mobile radios, amateur radio, AM and FM radio broadcast and TV broadcast cannot be predicted theoretically with accuracy.

To assess the electromagnetic environment due to fixed RF transmitters, an electromagnetic site survey should be considered. If the measured field strength in the location in which the AL-4000 is used exceeds the applicable RF compliance level above, the AL-4000 should be observed to verify normal operation. If abnormal performance is observed, additional measures may be necessary, such as reorienting or relocating the AL-4000. b Over the frequency range 150 kHz to 80 MHz, field strengths should be less than 3 V/m.

**Recommended separation distances between
portable and mobile RF communications equipment and the
AL-4000**

Table 206

The AL-4000 is intended for use in an electromagnetic environment in which radiated RF disturbances are controlled. The customer or the user of the AL-4000 can help prevent electromagnetic interference by maintaining a minimum distance between portable and mobile RF communications equipment (transmitters) and the AL-4000 as recommended below, according to the maximum output power of the communications equipment.

Rated maximum output power of transmitter W	Separation distance according to frequency of transmitter m		
	150 kHz to 80 MHz $d = 1.2\sqrt{P}$	80 MHz to 800 MHz $d = 1.2\sqrt{P}$	800 MHz to 2.5 GHz $d = 2.3\sqrt{P}$
0.01	0.12	0.12	0.23
0.1	0.38	0.38	0.73
1	1.2	1.2	2.3
10	3.8	3.8	7.3
100	12	12	23

For transmitters rated at a maximum output power not listed above, the recommended separation distance d in meters (m) can be estimated using the equation applicable to the frequency of the transmitter, where P is the maximum output power rating of the transmitter in watts (W) according to the transmitter manufacturer.

NOTE 1: At 80MHz and 800MHz, the separation distance for the higher frequency range applies.

NOTE 2: These guidelines may not apply in all situations. Electromagnetic propagation is affected by absorption and reflection from structures, objects and people.



This page is intentionally blank

9. INDEX

“To Axial” button	3-94
“Apply” button	3-100
“Cancel” button	3-100
“Cancel” button	3-104
“Confirm” button	3-104
“Menu” button	3-95
“Next” button	3-95
“Setting” button	3-98
“Delete” button	3-106
“Delete” button	3-106
“List” button	3-106
“Delete” button	3-107
“Delete” button	3-108
“To A-Diag” button	3-92
“To Utility” button	3-106

A

AC adapter	8-4
Accuracy	8-1, 8-2
ACD	1-6, 8-1
ACD velocity	8-1
A-constant	3-57
Acrylic	1-6, 4-10, 8-1, 8-2
A-Diag	1-6
Amplifier characteristics of the A-scan diagnosis	4-11
Analysis function	3-86
Angle	3-104
Aphakic	1-6, 8-1
Aphakic eye	3-24, 3-28, 3-37, 4-9
Appearance check	5-3
A-scan diagnosis	3-77
A-scan Diagnosis	8-3
A-Scan diagnostic probe	8-3
Attaching the biometry probe to the applanation tonometer	3-33

Attaching the probe sleeve	3-7
Auto	3-26
Auto measurement	3-67
Auto Power Off	3-96
Auto power off function	1-7, 2-20
Auto quick	3-26
Automatic connection upon startup	3-13
Automatic measurement (Auto / Auto quick)	3-41
Average	3-61
Average velocity of the axial length	8-1
AVG	1-6
Axial	1-6
Axial length	3-53, 8-1
Axial Length Measurement (Biometry) ...	2-9
Axial length measurement function	3-24

B

Basic structure and common items	2-7
Battery	8-4
BD address	1-6
BD Address	3-99
BD Address of Bureau	3-98
BD address setting examples	3-100
Bias value	1-7
Biometry probe	8-2
Biometry/IOL power calculations	8-1
Buttons and icons on the screen	3-91

C

Calculation	3-53
Calculation Method	3-101
Calibration	1-6
Caliper	1-7
Caliper function	3-51
CCT	1-6

Checking the measurement data	3-73	Data Arrange	3-105
Checking the software version	4-11	Data Selection Method	3-102
Checking waveforms after measurement ..	3-45	Date & Time Setting	3-96
Cleaning	5-3, 5-6	Deleting part of measurement data ..	3-48, 3-75
Clear all measurement data (preparation for measuring a new patient)	3-22	Dense Cataract	8-1
Common Setting	3-91, 3-93, 3-94, 3-95	Dense cataract eye	3-24, 3-28, 3-37, 4-9
Communicating via USB	2-8	Desired refractive power	3-56
Communicating via wireless access	2-8	Diagnosis in mode A	2-17
Communication check/wireless communication selection button	2-8	Displaying the optional waveform data ..	3-45
Connecting the AC adapter	3-4	E	
Connecting the A-scan diagnosis probe	3-77	Edit screen (data list)	2-11
Connecting the biometry probe	3-6, 3-24	Edit screen (waveform)	2-13
Connecting the corneal thickness/A-scan diagnosis probe	3-9	Entering calculation parameters	3-53
Connecting the footswitch	3-8	Entering the patient data	3-19
Connecting the pachymetry probe	3-61	Eye Axis Setting	3-91, 3-101
Connecting UD-8000, IOL calculation unit, and personal computer	3-10	Eye with initial stage cataracts	3-37
Connection for wireless communication	3-13	F	
Connection place list	3-98	Factory setting and setting range of the converted velocity	8-2
Connection place name	3-99	Function of pachymetry	8-2
Connection setting screen	3-99	G	
Connections	3-4	Gain	1-7
Contact	1-6	Gain setting	3-43, 3-79
Contact mode	3-30, 3-37	Gate	1-7
Contact/immersion mode settings	3-29	Gate change function	3-49
Corneal Thickness	3-93	H	
Corneal Thickness Setting	3-102	Handling the biometry probe in contact/immersion modes	3-30
Corneal refractive power and radius of corneal curvature (K1/K2)	3-55	Handling the slider in chin-rest measurement mode	3-32
Corneal thickness measurement	2-15	How to calculate axial length using the axial length measurement function	4-9
Cut (communication available)	2-8		
D			
D	1-6		

I	
Immersion.....	1-6
Immersion mode.....	3-30, 3-39
Initial Gain.....	3-101
Inspection	5-2
INSPECTION AND MAINTENANCE.....	5-1
Internal Memory Initialization.....	3-105
Internal Memory Management	3-91, 3-93, 3-94, 3-105
Intraocular pressure correction.....	3-73
Intraocular pressure data	3-74
IOL.....	1-6
IOL calculation screen	2-14
IOL Ey.....	8-1
IOL eye	3-24, 3-28, 3-37, 4-10
IOL Eye.....	8-1
IOL power calculation	3-53, 8-2
IOL power calculation formula	4-1
IOL thickness.....	8-2
IOL velocity.....	8-1
IOP	3-102
K	
K1	1-6
K2	1-6
L	
Language Setting	3-91, 3-93, 3-94, 3-97
Latest.....	3-61
Lens thickness.....	8-1
Lens velocity.....	8-1
M	
Main unit.....	8-3
Maintenance of main unit	5-8
Maintenance of measurement probes .	5-3, 5-6
Manual.....	3-26
Manual measurement	3-41, 3-67
Measurement	3-40, 3-66, 3-81
Measurement accuracy.....	8-2
Measurement Accuracy	8-1
Measurement point	1-7, 3-103
Measurement point display	3-70
Measurement range.....	8-1
Measurement resolution	8-2
Measurement Resolution	8-1
Measurement screen	2-9, 2-15
Measurement screen (FREEZE)	2-19
Measurement screen (real time).....	2-17
Measurement Selection	3-103
Measuring range	8-2
MI (mechanical index).....	4-12
Minimum	3-61
N	
NAMES AND FUNCTIONS.....	2-1
O	
Obj.....	1-6
Operation check.....	3-29, 3-65
OPERATION PROCEDURES.....	3-1
Operations for each setting.....	3-95
P	
Pachy	1-6
Pachymetry function	3-61
Pachymetry probe.....	8-2
Page No.	3-95
Parameter 1	3-74
Parameter 2	3-74
Percent bias	8-2
Percent bias/plus minus bias setting range...	8-2
Percentage bias	3-61
Phakic	1-6

Phakic eye	3-24, 3-28, 4-9, 8-1	Setting analysis method	3-80
Phakic Eye.....	8-1	Setting axial length calculation method and converted acoustic velocity for eye to be measured	3-24
Plus minus bias	8-2	Setting calculation conditions	3-53
Plus/minus bias	3-61	Setting how to display the converted acoustic velocity and bias value.....	3-61
PMMA.....	1-6, 4-10, 8-1, 8-2	Setting measurement conditions	3-19
Point analysis	3-88	Setting the beam direction	3-82
Post	1-6	Setting the data type to be displayed....	3-61
Precautions for measurement	3-30	Setting the gate cursor.....	3-44
Preparation before use.....	3-4	Setting the measurement mode/range and data display	3-63
Preparation for measurement.....	3-29, 3-65	Silicone	1-6, 4-10, 8-1, 8-2
Probe Light	3-101	SPARE PARTS AND OPTIONAL PARTS	7-1
R		SPECIFICATIONS	8-1, 9-1
Radio Comm. Setting	3-91, 3-93, 3-94	SRK/T formula	4-1
Radius	3-103	Sterilization.....	5-4, 5-6
Ref.	1-6	Sterilization conditions	5-5
Re-measurement of the same patient	3-42, 3-72	Storing	5-9
Replacing consumables	5-9	Switching modes.....	3-18
Replacing the probe holder	3-5	Switching to the A-scan diagnosis	3-77
Routine maintenance	5-2	T	
S		Target Place	3-98
S/I selection button.....	3-104	TIS (thermal index of soft tissue)	4-12
Saved data list ...	3-106, 3-107, 3-108, 3-109	Touch panel.....	1-7
Saving data.....	3-84	TROUBLESHOOTING.....	6-1
Saving measurement data	3-59	Turning the power on and adjustment after turning the power on	3-16
Saving the measurement data	3-76	U	
Screen	2-7	Ultrasound wave output	4-12
Screen Brightness	3-95	UP/DOWN arrow buttons.....	3-104
Select contact mode / immersion mode ...	3-101	US	1-6
Selecting specific axial length data to be used for calculating IOL power	3-47	User.....	8-1, 8-2
Selecting the eye to be measured.....	3-23	Utilities	3-90
Selecting the retina waveform	3-34		
Selecting the waveform on the back of the lens	3-35		

Utility menu screen of axial length measurement function	3-91	Volume	3-95
Utility menu screen of corneal thickness measurement function	3-93	W	
Utility screen of A-scan diagnosis.....	3-94	Waveform display.....	3-68
V		What is a good waveform?	3-37
Various functions in FREEZE mode	3-82	Wireless Communication	3-98
Various functions in real time mode	3-85	Wireless communication setting	3-12
Velocity of vitreous	8-1	Wireless Communication Setting	3-97
Version Information		Wireless connection with UD-8000 and IOL calculation unit.....	3-12
.....	3-91, 3-92, 3-93, 3-94, 3-110		



This page is intentionally blank

Manufacturer

Tomey Corporation
2-11-33 Noritakeshinmachi
Nishi-ku, Nagoya 451-0051 JAPAN
Tel: +81 52-581-5327
Fax: +81 52-561-4735

EC-Representative

Tomey GmbH
Am Weichselgarten 19a
91058 Erlangen GERMANY
Tel: +49 9131-77710
Fax: +49 9131-777120

AUTHORIZED TOMHEY SERVICE CENTERS

Headquarters, Pacific Rim

Tomey Corporation
2-11-33 Noritakeshinmachi
Nishi-ku, Nagoya 451-0051 JAPAN
Tel: +81 52-581-5327
Fax: +81 52-561-4735

Europe

Tomey GmbH
Am Weichselgarten 19a
91058 Erlangen GERMANY
Tel: +49 9131-77710
Fax: +49 9131-777120

