



ABERROMETER
MANUAL



OSIRIS

VIEWLIGHT
POWERED BY INNOVATION

Before use this instrument, be sure to read this manual

EN



INSTRUCTIONS FOR USE

CONTENTS

1. GENERAL WARNINGS.....	6
1.1. SYMBOLS.....	6
1.2. INTENDED USE AND OPERATING PROCEDURES.....	7
1.2.1. CLASSIFICATION.....	7
1.2.2. ENVIRONMENTAL CONDITIONS.....	8
1.2.3. REFERENCE STANDARDS.....	8
1.2.4. WARRANTY.....	9
1.3. SAFETY WARNINGS.....	10
1.4. DISPOSAL AT THE END OF LIFE.....	12
2. SUPPLY PACKAGE.....	13
2.1. LEGEND.....	14
2.2. IDENTIFICATION NAMEPLATE.....	15
2.3. SWITCHING ADAPTER NAMEPLATE.....	15
3. ROUTINE MAINTENANCE.....	15
4. USAGE.....	16
5. TECHNICAL SPECIFICATIONS.....	17
6. GUIDANCE AND MANUFACTURER'S DECLARATION.....	18
6.1. ELECTROMAGNETIC EMISSIONS.....	18
6.2. ELECTROMAGNETIC IMMUNITY.....	18

INSTALLATION

B1. INSTALLATION AND COMMISSIONING.....	21
------------------------------------------------	-----------

1. GENERAL WARNINGS

- These instructions describe how to use the Viewlight Osiris Aberrometer System correctly.



WAR NING:

Please carefully read this manual before using the device.

Thank you for choosing the Viewlight **OSIRIS Aberrometer** system.

Osiris is a high-performance system and like all Viewlight products has been manufactured with the greatest attention to functionality and safety. To use the device effectively and safely, please read this user manual carefully before installing and using the device, and follow the instructions and warnings reported in the manual and on the device. Operators who have used the device previously, should check again the instructions reported in this manual. The manual must be readily available for consultation.

The original text of this manual is in Italian.

1.1. SYMBOLS

Explanation of Symbols:



WARNING!

Symbol to point out attention on further information written in the Instruction for Use of the device.



Type B applied parts, in compliance with EN 60601-1 standards.



"Please refer to the instruction manual." It signifies that, for safety reasons, you need to consult the instruction manual before using the device



CE marking", indicates that the product is compliant with the EC Directive 93/42/EEC and subsequent amendments.



Disposal symbol in compliance with Directives 2012/19/UE WEEE and 2011/65/UE RoHS II.



Manufacturer

ISO 19980

ISO 19980 "Ophthalmic Instruments - Corneal Topographers".

Standard applicable to instruments that are intended to measure the surface shape of the cornea of the human eye.

INSTRUCTIONS FOR USE

1.2. INTENDED USE AND USAGE

The OSIRIS Aberrometer is an electromedical system for measuring corneal and ocular aberrations, for use in ophthalmological diagnosis by specialised medical staff and oculists.

This system is the result of a long research carried out by recognized professionals to bring new technology, quality and design together to the highest level.

The instrument

A revolution in the field of aberrometry, it enables assessment of the quality of the wavefront and measurement of ocular aberrations, thanks to its use of a PWS (Pyramidal WaveFront Sensor) and advanced software.

The software provided allows the following:

- Analysis of the patient's ocular wavefront in diverse conditions of refractive simulation, as well as the deviation
- from the ideal wavefront and refractive difference
- Zernike analysis of the wavefront measured
- A summary of the visual quality for assessment of the effect of the measured wavefront aberrations.
- Comparison and difference between aberration maps in follow-up assessments.

1.2.1. CLASSIFICATION

- **MEDICAL DEVICE classification**

Device classification in accordance with the rules set out in Annex IX of Directive 93/42/EEC and subsequent amendments: Class Im.

- **ELECTROMEDICAL DEVICES Classification**

Type of protection against direct and indirect contact: Class I

Applied Parts: Type B.

Degree of protection against humidity: Common device (no protection against water seepage) IP20.

Sterilization method: Disinfectable devices.

Degree of protection when used with anaesthetics or flammable detergents: No protection.

Conditions of use: Continuous operation:

Degree of electrical connection between the device and the patient: Devices with parts applied to the patient.

1.2.2. ENVIRONMENTAL CONDITIONS

The original packaging ensures the condition of the system's components for up to 15 weeks, in the transport and storage conditions indicated below. Once the components have been unpacked, or if the original packaging has been damaged or if said 15 weeks have already passed, the condition and safety of the components is no longer guaranteed.

Operating conditions of use:

- Temperature between +10 °C and +40 °C;
- Atmospheric pressure 800 hPa to 1060 hPa;
- Relative humidity between 30% and 90%.

Storage conditions:

- Temperature between -10 °C and +55 °C;
- Atmospheric pressure between 700 hPa and 1060 hPa;
- Relative humidity between 10% and 95%.

Vibration, sinewave 10 Hz to 500 Hz, 0.5g

Shock 30g, for 6ms

bump 10g, time: 6ms

1.2.3. REFERENCE STANDARDS

The following reference standards have been applied for product design, production and control:

Community Directives

- DIRECTIVE 93/42/EEC "MEDICAL DEVICES" OF 14/06/1993 AND SUBSEQUENT AMENDMENTS
- DIRECTIVE 2002/96/EC "Waste Electrical and Electronic Equipment".

Quality Management System Standards

- UNI EN ISO 9001:2008 "Quality management systems - Requirements"
- UNI EN ISO 13485:2012 "Medical devices - Quality Management Systems - Regulatory Requirements".

Technical Standards

- EN 60601-1 - "PART 1: MEDICAL ELECTRICAL EQUIPMENT: GENERAL REQUIREMENTS FOR SAFETY", third edition;
- EN 60601-1-2 - "Collateral standard: Electromagnetic Compatibility of Medical Electrical Equipment, 2007 edition;
- UNI EN ISO 15004: "Ophthalmic Instruments - Fundamental Requirements and Testing Methods, 2000 edition;
- UNI EN ISO 15004-1: "Ophthalmic Instruments - Fundamental Requirements and Testing Methods, Part 1: General requirements applicable to all Ophthalmic Instruments", 2009 edition;
- UNI EN ISO 15004-2: "Ophthalmic Instruments - Fundamental Requirements and Testing Methods, Part 2: Protection against light-related hazards", 2007 edition;
- UNI EN ISO 14971: 2012 "Application of risk management to medical devices"
- UNI ISO 19980:2012 "Ophthalmic Instruments - Corneal Topographers".

INSTRUCTIONS FOR USE

1.2.4. WARRANTY

Viewlight is liable for the device being in compliance with the Community Directive 93/42/EEC as amended by Directive 2007/47/EC, as well as for the device performance, safety and reliability, and consequently for the CE marking.

Viewlight will not be liable under the following circumstances:

- installation and commissioning are carried out without following the instructions and precaution warnings reported in the manual;
- the device is not used following the instructions and precaution warnings reported in the manual;
- accessories or spare parts are used other than those supplied or recommended by Viewlight.;
- repairs and safety controls are not carried out by skilled, qualified personnel, trained and authorised by Viewlight.;
- the electric system of the location where the device is installed does not comply with CEI standards and the law requirements in force.

Viewlight declines all liability for direct or indirect consequences or for damages to property or harm to persons caused by the improper use of the device or by incorrect clinical evaluations based on its use.

Viewlight warrants this product for a period of 24 months as of the date of manufacturing. This warranty covers the replacement, at Viewlight premises or at an authorised service centre, of components and materials, as well as the necessary working hours.

Shipping and transportation charges shall be born by the customer.

This warranty does not cover consumable parts or parts likely to wear in normal operation or parts damaged due to improper use or to maintenance carried out by personnel not authorised by Viewlight.

OUT OF WARRANTY CONDITIONS

- Repairs of faults caused by natural disasters, mechanical shock (fall, impact, etc.), defects of the electrical system, negligence, improper use, maintenance or repairs carried out with non-genuine products and/or by personnel not authorised by Viewlight
- Any use which is improper or falling out of the intended use as foreseen by the manufacturer.

Viewlight shall not be liable for any service deficiencies or inefficiencies due to causes or circumstances beyond its reasonable control. Under no circumstances, shall the customer be entitled to down time damages.

For maintenance or technical information on the device, please contact one of Viewlight Technical Service Centres or Viewlight directly at:

Viewlight

8380 NW 64 ST
Miami Fl 33166 - United States Of America
phone: +305-406-3915 · fax: +305-938-5012
customerservice@viewlightusa.com
www.viewlightusa.com

1.3. SAFETY WARNINGS



WARNING!

Do not touch the computer mains power cable with wet hands; make sure the mains power cable is not walked on or trapped under weights; do not tie the mains power cable.

- The power source must have a differential circuit breaker ($I\Delta n = 30 \text{ mA}$) and a thermal magnetic circuit breaker ($V_n = 230 \text{ V}$) to protect the device. The power socket must be close and easily accessible.
- A damaged power cable can cause fire or electric shock. It must be checked frequently. If the supplied computer power cable needs to be replaced, please contact the supplier.
- Do not attempt to carry out any technical intervention on the device or on the system unless specified in this manual.
- Do not use the device in the proximity of water and avoid liquid spillage on any surface of the device. Avoid humid or dusty places or places which are subject to rapid fluctuations in temperature and humidity.
- Unplug the device from the power socket before cleaning and/or disinfecting.
- The device does not generate or receive electromagnetic interferences when operated near other devices; no preventive or corrective action is necessary.
- No precautions are necessary in case of any changes affecting the device performance.
- In addition to the image capturing system, the device includes non electromedical appliances (Personal Computer, monitor, etc.). The standard configuration of the system supplied by Viewlight complies with EN 60601:1 standards (3rd edition), especially as per the requirements in chapter 16 of said standards. In addition to its standard configuration, the system can operate with other appliances (electromedical and not), therefore Viewlight could not verify compliance with the standards of all possible configurations.
- The configuration verified by Viewlight is the one with the Personal Computer outside of the patient's area.
- Any peripheral device (printer, scanner, CD player, etc) connected to the analogical or digital interface of the system must comply with the following



THE PERSONAL COMPUTER AND ALL PERIPHERAL DEVICES SHOULD BE PLACED OUTSIDE THE PATIENT AREA

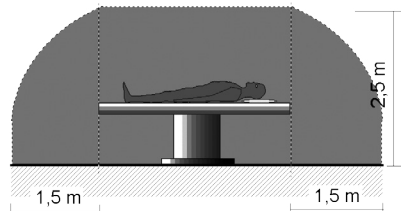
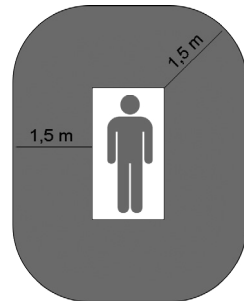

The patient area is the volume defined as shown in the figure, within which the patient may come into contact (intentionally or unintentionally, directly or through contact with the operators) with medical electrical and other devices making up the system

INSTRUCTIONS FOR USE

standards:

- » EN: 60950-1 for ITE equipment (safety standards for information technology equipment); or.
- » EN 60601:1 for medical electrical equipment;
- » The peripheral devices must be connected outside the patient's area;
- After connecting all the peripheral devices, the user is responsible for regularly verifying compliance of the electromedical system with EN 60601:1 standards (the specific requirements are reported in chapter 16 of the standards)
- If leakage current values exceed regulatory limits, further safety measures must be adopted, as indicated in the EN 60601:1 standards (3rd edition). In this case, the overall system must be powered through an adequate separator or isolation transformer.
 - » The transformer is absolutely necessary in case the operators cannot easily keep the computer and other non-electromedical appliances outside of the patients' area.



WARNING!

Only Viewlight branded equipment may be used or kept the patient area, along with the mains power unit (AC input 100-240V AC 0.75A max - DC output 24V - 2A).

The following parts of the system must instead be placed outside the patient area:

- Computer (desktop or laptop), with any peripheral device (monitor, keyboard, mouse, etc.);
- Printers;
- Other non-electromedical auxiliary devices (supply units/battery chargers, UPS, modem, etc.).

If the system needs to be connected to a computer network (LAM), all the necessary measures must be adopted to prevent transfer of dangerous voltage from remote stations, through the connected cables.

The use of data transfer devices ensuring "GALVANIC ISOLATION" may be necessary.

Viewlight shall not be held liable in relation to the patient and operator's safety in the case of electrical connections between the computer and other external units (peripherals) or LAN networks which are not made by Viewlight itself

1.4. DISPOSAL AT THE END OF LIFE

According to Directives 2012/19/UE WEEE and 2011/65/UE RoHS llon the restriction of hazardous substances in electrical and electronic equipment and on their disposal.

Public authorities adopt adequate measures to make sure that users, distributors and manufacturers contribute to the collection of electrical and electronic equipment, setting legal requirements for reusing, recovering or recycling said equipment.

The device purchased has been manufactured using special materials and substances. The device may contain hazardous substances potentially harmful to the environment or to human health if improperly disposed of into the environment.



WARNING!

The user must take into account the potentially harmful effects to the environment or human health due the improper disposal of the equipment or of parts of it.

To prevent the release of hazardous substances into the environment and to promote conservation of natural resources, the manufacturer, in case the user wishes to dispose of the device used at the end of its useful life, facilitates the possibility of its reuse and the recovery and recycling of the materials contained therein.



The graphic symbol shown in the figure is applied on the equipment's label.

It reminds that all electrical and electronic equipment must be collected and disposed of separately at their end-of-life

In the case of disposal of the device, specific provisions of European and national law apply, and provide that:

- the device shall not be disposed of as urban waste, it shall be collected separately, by contacting a company specializing in the disposal of electrical/electronic equipment or the public authorities responsible for waste management;
- in the event that a new piece of equipment is purchased from the same manufacturer to replace an old one placed on the market before 13 August 2005, equivalent and with the same functions of the new equipment, the distributor or manufacturer is legally required to collect the old piece of equipment;
- if the user wants to get rid of a used piece of equipment, placed on the market after 13 August 2005, the distributor or manufacturer is legally required to collect it
- by joining the specific technological waste disposal consortium, the manufacturer shall take care of the handling, recovery and/or disposal of the old equipment collected, at its own charge;

The manufacturer will provide the users with any information regarding the hazardous substances contained in the device and on the recovery and recycling of said substances, as well as on the possible reuse of the used device.

Violations shall be punished by the current legislation with serious administrative sanctions.

For more specific information concerning regulations on the disposal of equipment for countries other than Italy, please, contact your retailer

INSTRUCTIONS FOR USE

2. SUPPLY PACKAGE

The system is composed of the following main units:
Main unit, designed and manufactured by Viewlight, com-posed of:

1. Aberrometer
2. Table top mains power supply (AC input 100-240V AC 0.75A max - DC output 24V 1.90A)
3. Software provided

Accessories provided

The system is supplied with the following accessories:

- two guide guards;
- instrument cover;
- one set of Allen wrenches;
- one set of chinrest papers;
- one set of calibration and verification cross-hairs

Optional

- Isolation 230V / 230V transformer for use in the operating theatre (leakage current limiter)
- Motorised adjustable elevating table with telescopic lifter, brand SCHUMO AG, Model TES2 23 / TA0113 X20 400238Z;

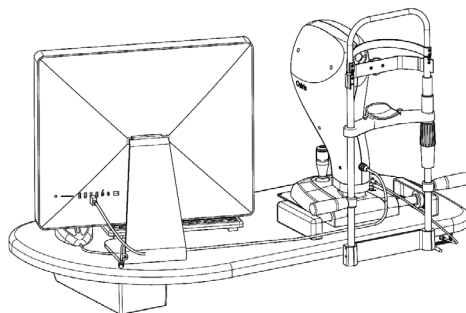

INSTRUCTIONS FOR USE

2.1. LEGEND

1. "OSIRIS" instrument
2. Calibration test cross-hairs
3. Chinrest
4. Table
5. Switching
6. Drawer
7. Forehead rest
8. Chinrest support
9. Chinrest adjuster knob
10. Handrest
11. Guide guard
12. Geared guides
13. Sliding device base plate
14. Switching adapter switch
15. Power lamp
16. Instrument power supply cable
17. Mains supply cable
18. USB3 cable
19. Switching adapter data nameplate
20. -
21. Joystick
22. Acquisition button
23. Geared wheels
24. Locking knob
25. LED lighting
26. POWER IN
27. POWER OUT
28. Shooting lens.

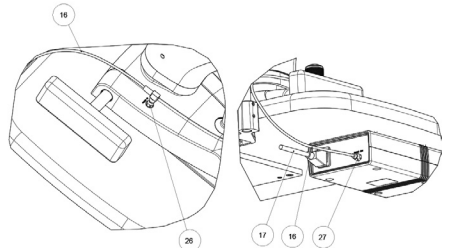
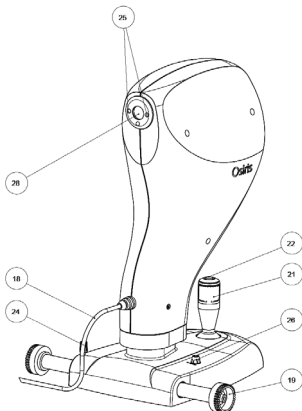
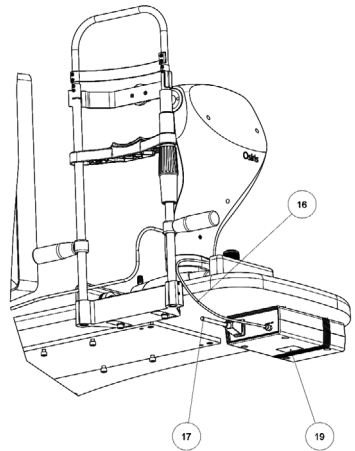
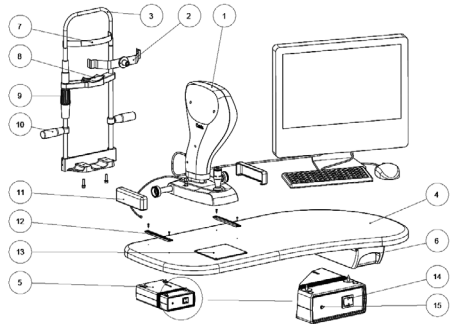

INSTRUCTIONS FOR USE

2.2. IDENTIFICATION NAMEPLATE

Data reported on the nameplates:

- Manufacturer's name.
- Device name.
- Serial number.
- Month and year of manufacture.



2.3. SWITCHING ADAPTER NAMEPLATE

Data on the label:

- Manufacturer's name.
- Model of the power supply unit.
- Serial number.

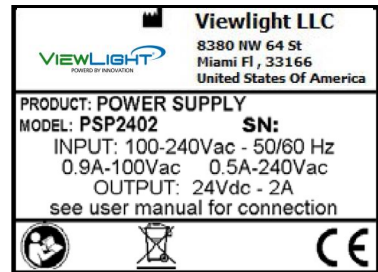

3. ROUTINE MAINTENANCE

The system does not require any particular routine maintenance operations by the user.

To clean the external surfaces simply use a cloth slightly dampened with water.



WARNING!
Do not use any thinners or solvents.

Protection against dust

When not in use, protect the system against dust by placing it back in its case. Dust accumulating on the device must be regularly removed with a soft cloth or blower.

Extraordinary maintenance operations (repairs, components replacement, check of internal components, etc.) fall within the exclusive competence of Viewlight Technical Service.

The manufacturer agrees to provide, upon motivated request: diagrams, lists of components, specific technical instructions which might be useful to authorized and pre-trained personnel for maintenance and calibration.

4. USAGE

- a) Have the patient comfortably sit down with his/her chin on the chinrest and the forehead against the forehead rest.
- b) Lift and lower the chinrest using the handle to align the patient's eyes with the central eyepiece of the instrument.
- c) Enter the program; to use the aberrometer follow the main instructions below:
 - c1) Click on "Create new patient" and enter the patient's FIRST NAME, LAST NAME and DATE OF BIRTH (mandatory). If the patient already exists in the database, simply enter his last name and select him from the list.
 - c2) Click on acquire and select the Topo-Aberrometer tool.
- d) Move on to the instrument. To run an aberrometry measurement, centre the reflection of the fixation point with the joystick (21), and focus the edge of the iris. Press the button on the Joystick (22) to acquire the image.
- e) It is possible to acquire multiple images consecutively.
- f) Select the gallery tab to preview the images.
- g) Exit the acquisition window to save the images to the gallery. At this point, the exam is complete



WARNING!

To avoid the risk of electric shock this device must only be connected to a power supply system with protective earthing.

FOR ISOLATION FROM THE MAINS (condition of complete safety) THE COMPUTER POWER CABLE MUST BE DISCONNECTED.

To turn off the system, follow the usual procedure to exit the software, then switch off the computer power switch.

Do not switch off the computer or disconnect the cable between the Computer and the Aberrometer, when the program is in use.

INSTRUCTIONS FOR USE

5. TECHNICAL FEATURES

Operation distance	79 mm
Device Power supply	Through 24V DC external power supply unit
Mains power	Switching adapter 100-230V
Weight	6.2 Kg
Size (HxWxD) mm	418x313x267 mm
Computer connection	USB3 cable
LED lighting source	IR LED 850 nm
Measurement range (sph, VD = 0 mm)	from -25d to + 15d
Measurement range (cyl, VD = 0 mm)	up to 10 d
Resolution on pupil	41 μ m (45.000 points at maximum pupil)
Pupil measurement range	\varnothing 1 mm \div \varnothing 9 mm
Acquisition time + processing time	33 ms for aberrometry (30 measurements/s)
Alignment	Manual

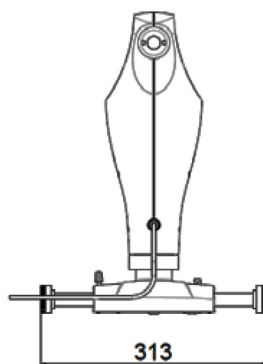
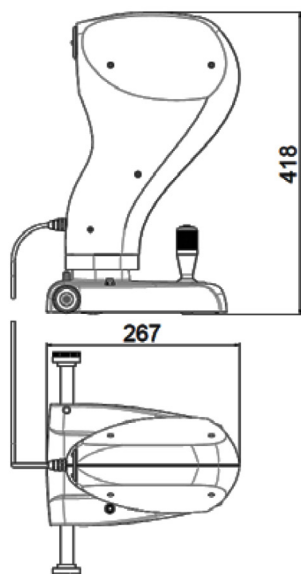

6. GUIDANCE AND MANUFACTURER'S DECLARATION

6.1. ELECTROMAGNETIC EMISSIONS

TABLE 1- Guidance and manufacturer's declaration – electromagnetic emission		
The OSIRIS-T device is intended for use in the electromagnetic environment specified below. The customer or the end user of the OSIRIS-T device should assure that it is used in such an environment.		
Emission test	compliance	Electromagnetic environment - guidance
RF emission - CISPR 11	Group 1	The OSIRIS device uses RF energy only for its internal function. Therefore its emissions are very low and are not likely to cause any interference in nearby electronic equipment.
RF emission - CISPR 11	Class B	The OSIRIS device is suitable for use in all establishments including domestic establishments and those directly connected to the public low voltage power supply network that supplies buildings used for
Harmonic emissions IEC 61000-3-2	Class A	The OSIRIS device is suitable for use in all establishments including domestic establishments and those directly connected to the public low voltage power supply network that supplies buildings used for
voltage fluctuation/flicker emission IEC 61000-3-3	compliant	The OSIRIS device is suitable for use in all establishments including domestic establishments and those directly connected to the public low voltage power supply network that supplies buildings used for

INSTRUCTIONS FOR USE

6.2 ELECTROMAGNETIC IMMUNITY

TABLE 2 - Guidance and manufacturer's declaration – electromagnetic immunity.

The OSIRIS device is intended for use in the electromagnetic environment specified below. The customer or the end user of the OSIRIS-T device should assure that it is used in such an environment.

Immunity test	IEC 60601 Test level	Compliance level	Electromagnetic environment - guidance
Electrostatic discharge (ESD – Electro Static Discharge) IEC 61000-4-2	±6kV contact ±8kV air	±6kV contact ±8kV air	Floors should be wood, concrete or ceramic tile. If floors are covered with synthetic material, the relative humidity should be at least 30%
Electrical Fast Transient/Burst IEC 61000-4-4	±2 kV for power supply lines ±1 kV for I/O lines	±2 kV for power supply lines Not applicable	Mains power quality should be that of a typical commercial or hospital environment
Overvoltage IEC 61000-4-5	±1 kV differential mode ±2 kV	±1 kV differential mode ±2 kV	Mains power quality should be that of a typical commercial or hospital environment
Voltage Dips, short interruptions and voltage variations on power supply input lines IEC 61000-4-11	<5% Ut for 0.5 cycle 40% Ut for 5 cycles 70% Ut for 25 cycles <5% Ut for 5 sec	<5% Ut for 0.5 cycle 40% Ut for 5 cycles 70% Ut for 25 cycles <5% Ut for 5 sec	Mains power quality should be that of a typical commercial or hospital environment. If the user of the OSIRIS device requires continued operation during power mains interruptions, it is recommended that the OSIRIS device be powered from an Uninterruptible Power Supply or Battery.
Power frequency (50/60Hz) magnetic field IEC 61000-4-8	3 A/m	3 A/m	Power frequency magnetic fields should be at levels characteristic of a power supply network of a typical commercial or hospital environment

Note: Ut is the AC mains voltage prior to application of the test level

INSTRUCTIONS FOR USE

TABLE 3 - Guidance and manufacturer's declaration – electromagnetic immunity.

The OSIRIS -T device is intended for use in the electromagnetic environment specified below. The customer or the end user of the OSIRIS -T device should assure that it is used in such an environment.

Immunity test	IEC 60601 Test level	Compliance level	Electromagnetic environment - guidance
<p>Conducted RF IEC 61000-4-6</p>	<p>3Vrms Da 150 kHz to 80 MHz</p>	<p>3 Vrms 3 Vrms</p>	<p>Portable and mobile RF communication equipment should be used no closer to any part of the OSIRIS, including cables, than the recommended separation distance calculated from the equation applicable to the frequency of the transmitter.</p> <p>recommended separation distance.</p> <p>$d=1.167*\sqrt{P}$</p> <p>$d=1.167*\sqrt{P}$ 80 MHz to 800 MHz</p> <p>$d=2.333*\sqrt{P}$ 800 MHz to 2.5 GHz</p> <p>where P is the maximum output power rating of the transmitter in watts(W) according to the transmitter manufacturer and d is the recommended separation distance in metres (m)</p> <p>Field strengths from fixed RF transmitters, as determined by an electromagnetic site survey, should be less than the compliance level in each frequency range.</p> <p>Interference may occur in the vicinity of equipment marked with the following symbol:</p> <div style="text-align: center;">  </div>

Note 1: at 80 MHz and 800 MHz, the higher frequency range applies.

Note 2: These guidelines may not apply in all situations. Electromagnetic propagation is affected by absorption and reflection from structures, objects and people.

INSTALLATION

B1. INSTALLATION AND COMMISSIONING

All equipment composing the system is always delivered packaged in optimal conditions to withstand standard transport and storage conditions. In the event that, when removing the device from its packaging, damages due to transport are detected, please contact the installer company or the manufacturer directly.

- Make sure the electric system power supply voltage matches the voltage indicated on the external power supply unit (AC/DC Adapter) and computer data label. If the voltage does not match contact the technical service centre or the manufacturer.
- In Italy, the electrical system must meet IEC 64-4 standard or section 710 of the most recent IEC 64-8 standard (electrical systems in medical environment). Should you have any doubts, please contact the electrical installation and maintenance company in charge of your electrical system.
- Do not use multiple sockets, adapters or extension cables to connect the device plug to the mains socket.
- To disconnect from the power supply, also in case of emergency, grab the plug of the power cable; do not pull the power cable to unplug the device.

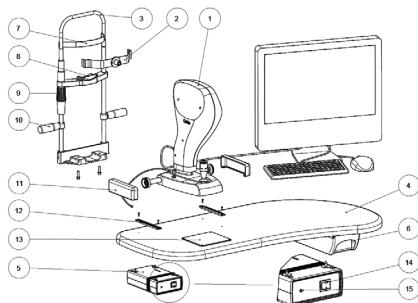

To assemble the device follow the instructions below:

1. Secure the table top to a base; the instrument holder table is below the device ready for assembly - proceed as follows:
 - a) Position the table on the base plate and insert the screws provided;
 - b) Fix the top to the bottom by tightening the four hexagon socket head screws
2. Unscrew the two hexagon socket head screws under the chinrest. Insert the screws in the chinrest module and align its holes with the holes of the table top. Tighten the screws with the wrench provided with the device.
3. Place the base with orthogonal movements on the guides on top of the instrument holder table; make sure the wheels are aligned. Lock the device with the knob (24) on the right side of the base, above the wheels axis.
4. Fix the guards (11) along the guides by inserting the tabs into their slots.
5. Connect the computer to the mains. Switch on the computer.
6. If the software is not already installed, follow the instructions in the user manual supplied with the software to install it.

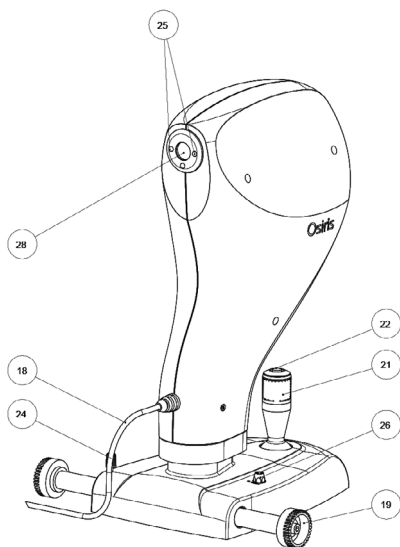

INSTALLATION

7. Connect the device socket (27) to the power supply unit socket (26) with the cable (16)
8. Connect the power supply unit to the mains socket with the cable (17)
9. Turn on the power supply unit (14).
10. Connect the USB cable (18) to the computer.
11. The system is ready for use.
12. Follow the aberrometer driver installation procedure as given in the phoenix software manual.

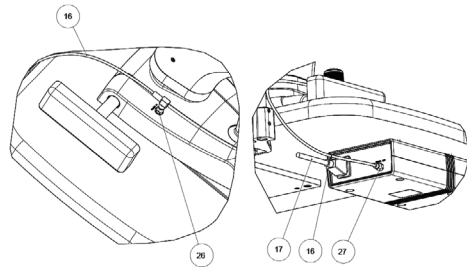



Viewlight LLC

8380 NW 64 St
Miami Fl 33166 - United States Of America
phone: +305-406-3915 · fax: +305-398-5012

customerservice@viewlightusa
www.viewlightusa.com



90000020
rev. 001
05/2017