

VIEWLIGHT
POWERED BY INNOVATION

CLINICAL SLIT LAMP

MANUAL



CSL-7U

Before use this instrument, be sure to read this manual

EN

Thank you for purchasing our slit lamp microscope! The following is the description and specification of our product.

General description

- ☞ This user manual elaborates on the relevant technical specification and operation notes of our slit lamp.
- ☞ Working principle: A beam of light attached to the slit lamp projects to the patients' eye, which forms an optical section of the living tissue of the eye, in this way the doctor can finish the observation and examination.
- ☞ Slit Lamp Microscopes are used to observe the disease of the anterior structures and tissue damage of eyes.

The specification of this slit lamp microscope.

Microscope:

Type:	Galilean-Type
Magnification change:	Three Position revolving Drum
Eyepieces	12.5X
Angle between eyepieces:	13°
Total magnification Ratio:	10X, 16X, 25X (Standard)
Pupillary adjustment:	52mm~78mm
Diopter adjustment:	±6D
Field of view:	25X (Ø8.5mm), 16X (Ø13.5mm), 10X (Ø22mm)

Slit Illumination:

Slit width:	Continuously variable from 0 to 14mm (at 14mm, slit becomes a circle)
Slit length:	Continuously variable from 1mm to 14mm
Aperture diameters:	Ø14mm, Ø10mm, Ø5mm, Ø3mmØ2mm, Ø1mm, Ø0.2mm
Slit angle:	0°-180°
Slit inclination	4 step: 5°、10°、15°、20°
Filters:	thermal safety、UV、Red-free、Cobalt Blue
Lamp:	6V/20W Halogen Lamp

Base

Longitudinal movement:	90mm
Lateral movement:	100mm

Fine Base movement: 15mm

Vertical movement: 30mm

Chin-Rest

Vertical movement 80mm

Fixation Target LED

Power:

Input voltage: 220V/110V $\sim\pm 10\%$

Input frequency: 50Hz/60Hz

Power Consumption: 30VA (max)

Output voltage:

Light: 6V

Fixation: 3V

Dimension & Weight:

Dimension 740mm \times 450mm \times 500mm

Gross weight: 25Kg

Net weight: 17Kg

Working environment

Temperature: $+5^{\circ}\text{C} \sim +40^{\circ}\text{C}$

Relative humidity: $\leq 80\%$

Air pressure: 800hpa \sim 1060hpa

Storing environment

Temperature: $-40^{\circ}\text{C} \sim +55^{\circ}\text{C}$

Relative humidity: $\leq 93\%$

Air pressure: 700hpa \sim 1060hpa

Transporting environment

Temperature: $-40^{\circ}\text{C} \sim +55^{\circ}\text{C}$

Relative humidity: $\leq 93\%$

Air pressure: 700hpa \sim 1060hpa





General Requirements for Safety

Please read carefully the following precautions to avoid unexpected personal injury as well as the product being damaged and other possible dangers.

Precautions

1. In case there is any trouble, please first refer to the trouble-shooting guide. If it still can't work, please contact the authorized distributor or our Repair Department.
2. Do not use this instrument in the environment prone to fire and blast or where there is much dust and with high temperature. Use it in room and simultaneously be careful to keep it clean and dry.
3. Check that all the wires are correctly and firmly connected before using. Ensure that the instrument is well grounded.
4. Please pay attention to all the ratings of the electrical connecting terminal.
5. Turn off the main power first before replacing the main bulb, flash lamp and fuse.
6. When replacing the power cable, please use the power cable in accordance with the notes in the instruction manual.
7. Don't touch the surface of the lens and prism with hand or hard objects.
8. To prevent the instrument from falling down to floor, it should be placed on the floor where the inclination angle is less than 10°
9. Read carefully the safety and other signals on this machine in order to use the product safely.

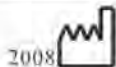
THE SAFETY MARKS, PICTURES USED IN THIS INSTRUMENT

No.	mark	Description
1		TYPE B
2		DATE
3	Class I	The slit lamp is type I medical using equipment
4	Type B	English form of B type
5		WEEE mark Please deal with the waste disposal produced by the machine following relevant laws and regulations.
6	CE	CE marking
7	PN:	Part Number
8	SN:	Serial Number
9		ON
10	○	OFF
11	Output	At the back of power supply box ,indicate outlet of the power
12	Input	At the back of power supply box ,indicate input of the power
13	Fuse 110V:2A 125V 220V:1A 250V	Rated value and current value
14	Power	At the front of power supply box, use with on and off
15	Voltage selector	Change input voltage to adjust the equipment to work under appropriate voltage
16	luminance 	THE MARKS OF LIGHT

Contents

1	Nomenclature	5
2	Assembly	8
	2.1 Check List	8
	2.2 Assembly procedure	9
	2.3 Checking procedure after assembling	11
3	Operation procedures	12
	3.1 Diopter compensation and Pupil Distance adjustment	12
	3.2 Patient position and use of fixation target	13
	3.3 Base operation	13
	3.4 Operation of illumination unit	13
	3.5 Operation notes	15
4	Maintenance	15
	4.1 Cleaning and maintenance	15
	4.1.1 Cleaning way	15
	4.2 Protecting	16
	4.3 Adjusting the tightness of the slit width knob	16
	4.4 Adjusting the inclination of the illumination part	16
	4.5 Replacing the illumination bulb	16
	4.6 Replacing the fuse	17
	4.7 Replacing the chin-rest paper	18
	4.8 Consumables	18
5.	Trouble shooting guide	19
	Appendix A	20
	Appendix B	20

1 Nomenclature

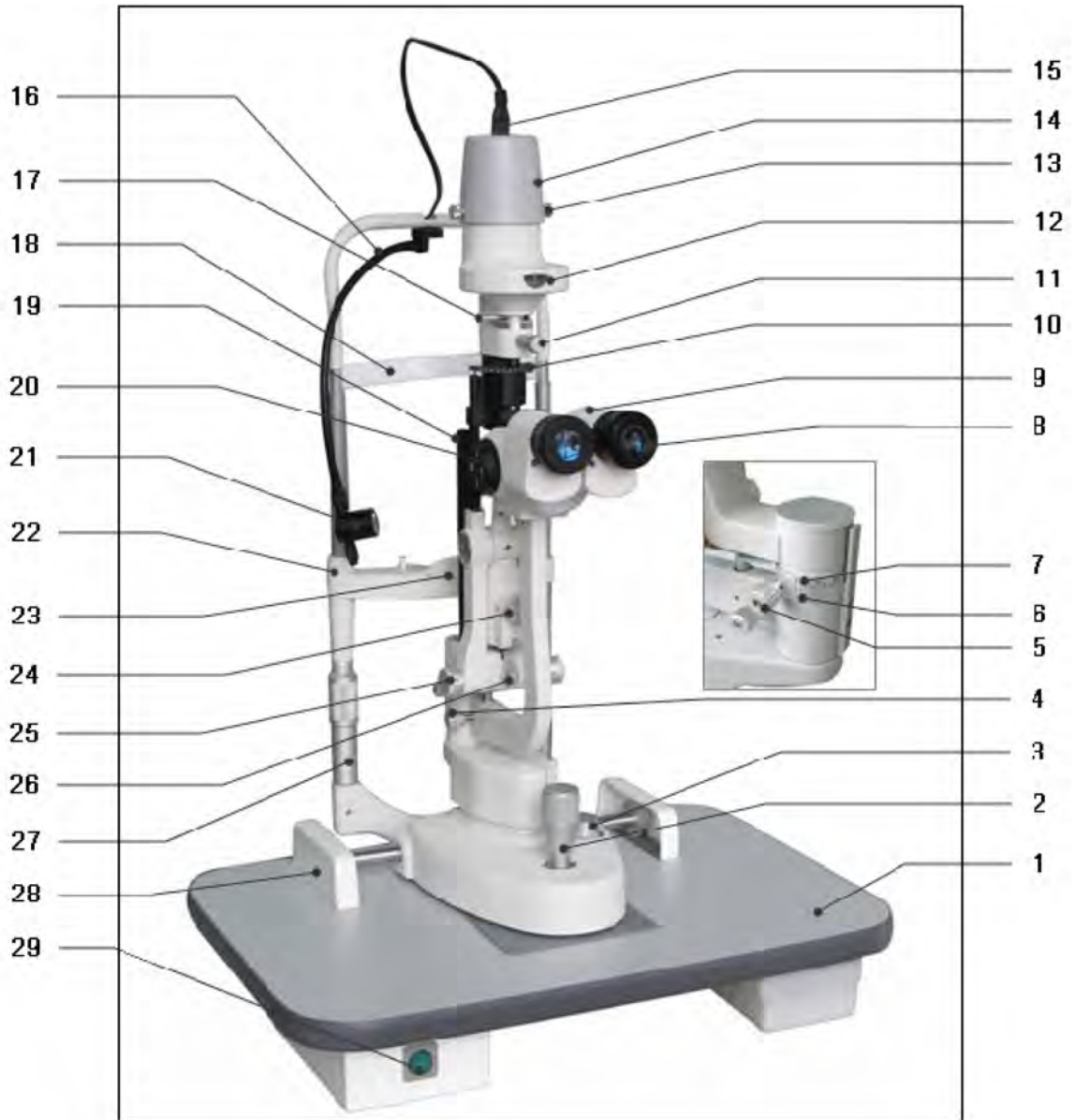

1. Work Table
2. Joystick
Incline joystick to move the instrument slightly on the horizontal surface and rotate it to adjust the elevation of the microscope.
3. Brightness Control Switch
The brightness can be adjusted continuously. Avoid working continuously at high setting, as the service life of the bulb will be shortened.
4. Microscope Arm Locking Knob
Lock the rotational movement of the microscopes arm.
5. Illumination Arm Locking Knob
Lock the rotational movement of the illumination arm.
6. The indicate of relative angle between the microscope and illumination unit
Mark on the angle mark ring of the illumination arm, which relates to the long mark of the microscope arm, represent the two arms' angle when the "0" on the ring relates to the short mark at one side of the operator the right eyepiece may be blocked, and the side of the patient the left eyepiece.
7. The mark of microscope arm
Together with (6) to indicate the angle between the microscope and illumination unit
8. 12.5X Eyepieces
9. Prism Box
Separate the prism box to adjust the inter papillary distance until it fit for checking
10. The Control Plat of Slit
11. Slit Height Control Knob
12. Aperture Slit Height and Display Window
It will display the diameter of the slit and the aperture.
13. The Fixation Knob of Lamp Cap
After fixing the knob, the lamp cap will not move.
14. Lamp Cap
With the function of protecting and insulating, its normal working temperature is around 51 °C.
15. The plug of Lamp cap
It is connected with the power of the light unit.
16. Fixation target
Make the patient stare at it, it is convenient for checking
Rotate this knob to adjust the spot and the slit height. Swing the knob horizontally to revolve the slit.

17. Filter Selection Lever and display mark

The lever can choose different filters.

18. Forehead Belt

To fix the patient's head on an appropriate position

19. Focus test rod

20. Magnification Select Dial

Three or five different magnifications are provided

21. Backlit background illumination model (optional)

22. Chin-rest

23. The Fixation Knob of Chin-rest Paper

It is used to fix the chin-rest paper.

24. Centering Knob of illumination unit

Loosen the knob to allow the illumination light to move from the center of the vision field for indirect retro-illumination. Fastening the knob can bring the illumination light back to the center.

25. Slit Width Control Knob

The slit width is continuously adjustable within the range from 0 to 14mm. The marks on the left knob stands for the approximant value of the width.

26. Illumination Inclination Lever

Four inclination stops are available from 5° up to 20°. The interval between each is 5°.

27. Chin-rest Elevation Adjustment Knob

Rotate the knob to adjust the elevation of the chin-rest

28. Rail Cover

Protect the rail surface

29. Main Power Switch

2 Assembly

This section of the manual describes how to assemble the slit lamp. All parts should be taken out with great care from the packing case before assembling.

2.1 Check List

NO.	MARK	NAME	QUANTITY	NOTE
1	A	HEAD-REST PART	1	Fig.2.1.1
2	B	MICROSCOPE PART	1	Fig.2.1.2
3	C	ILLUMINATION PART	1	Fig.2.1.3
4	D	WORK TABLE PART	1	Fig.2.1.4
5	E	RAIL COVER	1	Fig.2.1.5
6	F	BREATH SHIELD	1	Fig.2.1.6
7	G	INPUT POWER CABLE	1	
8	H	FOCUSING TEST ROD	1	Fig.2.1.7
9	I	PROTECTING CAP	1	
10	J	CHIN-REST PAPER	1	
11	K	SCREW DRIVER	1	
12	L	SPARE BULB	1	Fig.2.1.8
13	M	USER MANUAL	1	
14	N	PACKING LIST	1	

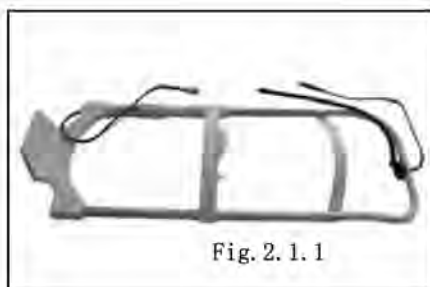

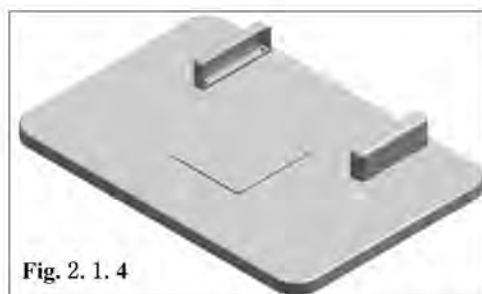

2.2 Assembly procedure

1. Open the carton, take out the tools like screw driver and spanner.
2. Check the setting on the voltage selector located on the bottom of the power box. If it doesn't match with the input voltage, slide it to the proper position with watch screw driver. Take out the table unit check whether the power switch is in the proper position, if not use the screw driver to correct it. (caution)

Open the fuse holder with screw driver and take out the fuse, It has been set to 220V, 1A before leaving factory.



Attention: Set the input voltage and frequency of the instrument according to that of the mains.

3. Before attaching the worktable (Fig.2.1.4) on to the power table, please screw off four M6x20mm bolts with the spanner. (Fig.2.2.1 A Team) .

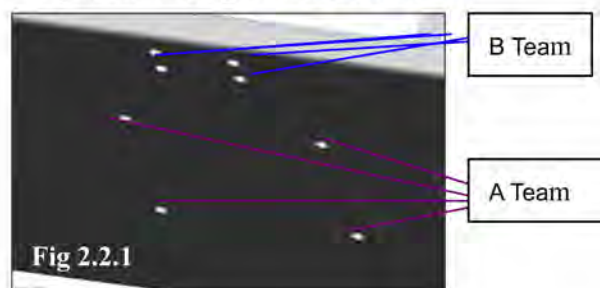

4. Lift the worktable to aim its screw hole at the assembly hole of the instrument table. (Fig.2.2.2)
5. Put down the worktable, with the power panel facing the operator, refasten the bolt

securely with the spanner (Fig.2.2.2) .



The screw to connect with the electrical table

6. Connect two white adapters under table board, Turn on and press Up & Down switch to check whether the power table is normal. (Fig.2.2.3) .

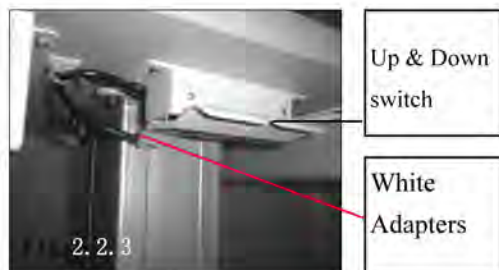

7. Remove the four screws of B Team with the screw drive (Fig.2.1.4), take out the head-rest from carton (Fig.2.1.1), ensure the four hole on head rest aim the screw hole of B team (Fig.2.2.1 B team), retighten the previously removed screw make head-rest connect with work table. (Fig. 2.2.4)

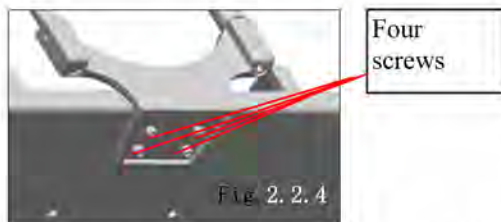

8. Take out the slit lamp part (Fig.2.1.3), put it on the rails of the table board, check whether the wheels can be rolled steadily on the rails. (Fig.2.2.5), place the rail cover to the rail, remove four screws

attached to the rail with the screw drive, retighten the previously removed screws. (Fig.2.2.5 and 2.2.6) .

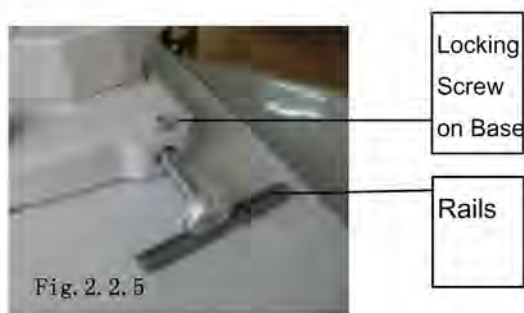
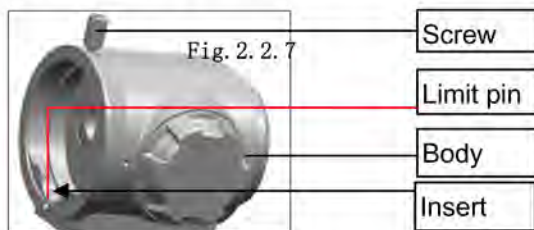
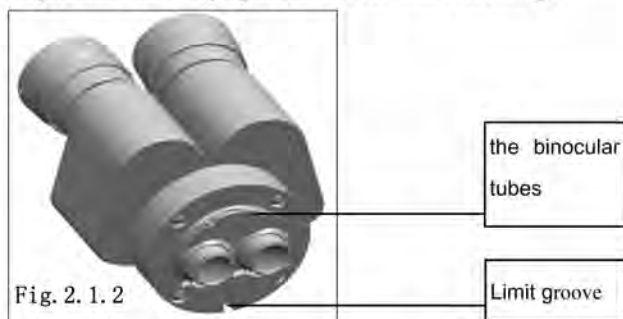

Fig. 2. 2. 6

10. Take out the binocular tubes of microscope part (Fig.2.1.2), match the groove on the binocular tubes with the pin on the microscope body. Fasten the fixing screw on the body to the microscope.

⚠ ATTENTION : Don't touch the objective and eyepiece when assembling.



11. Remove the breath shield fixation screw

from the microscope arm, pass the removed screw through the hole of the breath shield and then screw it into the arm again (Fig.2.2.8).

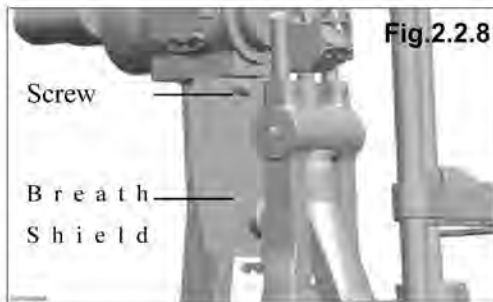

12. Insert the plug on the top of the headrest part (Fig.2.1.1) into the socket of the lamp cap (Fig.2.1.3) on the illumination part.

13. Connect the plug below the headrest part with the corresponding output socket of the power box.

14. Collect tools and spare parts, put them into the drawer under right side of table board.

2.3 Checking procedure after assembling

15. This instrument supplies a 3-wire cable. Please select a proper power socket as matched. Ensure that the instrument is grounded well.

16. When the main power switch of the power box is placed at 'I', it turns on, and 'O' for turn off. The main power switch should be set at the 'O' position before connecting the input cable with the power socket.

17. Turn on the main power switch, and the pilot lamp will be lighted. Open the light control knob to examine the brightness. The power supply signal will turn bright when power is connected (Fig.3.1.3).

18. Put on focus test rod (Fig.2.1.7),

Adjust the slit width control knob and there should be facula on the black flat surface

of focus test rod, and the brightness should change.

19. Check the fixation target device to confirm it is lighted. Ensure it can be normally lighted (Fig.3.2.1)

20. Check whether all the moveable parts such as aperture and slit height control knob (Fig.2.3.2) filter selection lever, joy stick (Fig.2.3.4) and magnification changer lever (Fig.2.3.3) etc. could be operated freely.

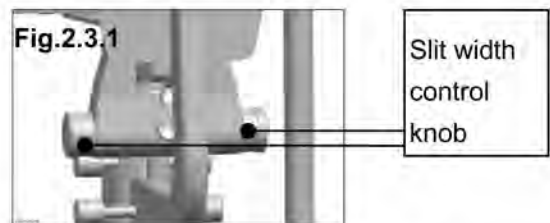

21. Turn on the light knob (Fig.3.1.3), the light should be from dark to bright.

22. After examination, turn off the main power and cover the instrument with the dust-proof cover.

3 Operation procedures

3.1 Diopter compensation and Pupil Distance adjustment

① Use of the focusing test rod

The rod is supplied as one of standard accessories for confirming the microscope's accurate adjustment. Insert it into the main shaft hole with the black flat surface facing the objective lens i.e. the direction of the operator (Fig.3.1.1 & 3.1.2).



ATTENTION : After the

adjustment, take out the rod.

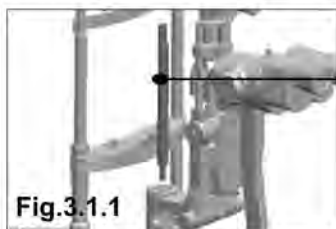

Insert the rod to the hole

Fig.3.1.1



The flat faces microscope

Fig.3.1.2

② Brightness adjustment

Switch on the main power switch and set the brightness control switch (Fig.3.1.3) at central part. Turn the slit width control knob (Fig.2.3.1) to make the slit width to be 2~3mm.



Fig.3.1.3



Dark Bright

Brightness control switch

③ Adjustment of Diopter compensation

The focus of the microscope is calibrated according to the emmetropia. If the operator is an ametropia, he should adjust the eyepiece diopter (Fig.3.1.4).

Suggest adjusting the diopter as following procedures:

First, rotate the diopter adjustment ring counter clockwise until the end.(Fig.3.1.4)

Second, rotate the ring clockwise until a fine slit image appears on the focusing text rod. At this time, it is also the clearest observation of the reticule in the eyepiece

Adjust another eyepiece in the same way.

Record the diopter value on each eyepiece for future reference.



Fig.3.1.4

Diopter adjustment ring

④ Interpupillary distance adjustment

Separate the prism box of the microscope with both hands to adjust the P.D. until both eyes could see the same image on the focusing test rod through the eyepieces, and at the same time a stereo vision will be obtained. When adjusting, be sure that the eyepieces are at the same level (Fig.3.1.5).



Fig.3.1.5

the prism box

3.2 Patient position and use of fixation target

1) Position of the patient's head

Place the patient's chin on the chin-rest with the forehead against the forehead-rest belt. Adjust the chin-rest elevation adjustment knob below the chin-rest until the patient's can thus align with the horizontal mark (Fig.3.2.1).

2) Use of the fixation target

For fixing the patient's sight, just make him look at the fixation target with the eye not to be examined. Move the lamp bar to change fixing position, so as to achieve the correct lamp position



Fig.3.2.1

3.3 Base operation

1) Horizontal rough adjustment

Keep the joystick erect and move the base to make the microscope move on the horizontal surface to aim at the object appropriately (Fig.3.3.1)

2) Vertical adjustment

Rotate the joystick to adjust the microscope's height until it aligns with the

target. Turn the joystick clockwise to raise the microscope and counter clockwise to lower it (Fig.3.3.1).

3) Horizontal Fine adjustment

Tilt the joystick to make the microscope move slightly on the horizontal surface. While watching through the eyepieces, tilt the joystick to aim accurately at the object for a fine image. (Fig.3.3.1)

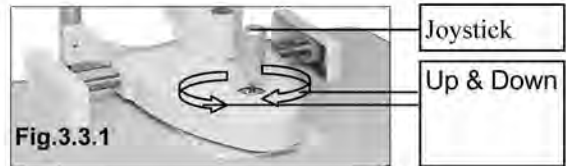

Fig.3.3.1

4) Locking the base

When finishing the adjustment, fasten the base locking screw to lock the base to prevent it from sliding. (Fig.3.3.2)



Fig.3.3.2

3.4 Operation of illumination unit

1) Changing the slit width

Turn the slit width control knob (Fig.2.3.1) and the slit width will be changed from 0mm to 14mm. The slit becomes a circle at the 14mm size. The width value is indicated approximately by the scale on the knob. (Fig.3.4.1)



Fig 3.4.1

2) Changing the aperture and slit height

Turn the aperture and slit height control knob and 7 different circular beams of light are available at full aperture: 14,10,5,32,,1,0.2 Dia. Respectively and one continuously changing aperture With a slit image, the slit height can be changed continuously from 1 to 14mm, which is indicated though the display window (Fig.3.4.2).



3) Rotating the slit image

Swing the aperture and slit height control knob horizontally to revolve the slit image at any angle in the vertical or horizontal direction. The angle of image rotation is indicated by the rotation angle scale with small division for 5° and big division for 10° (Fig.3.4.3).

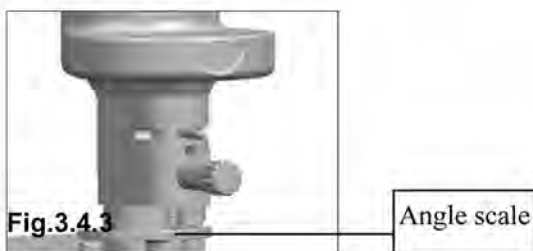

4) Decentering the illumination light

Loosen the centering knob and swing the slit width control knob back and forth so the light spot moves away from the center of the microscope vision field. It is mainly used to examine the eyes by indirect retro-illumination. Fasten the centering knob and the slit light will return to the center of the microscope vision field

(Fig.3.4.4).

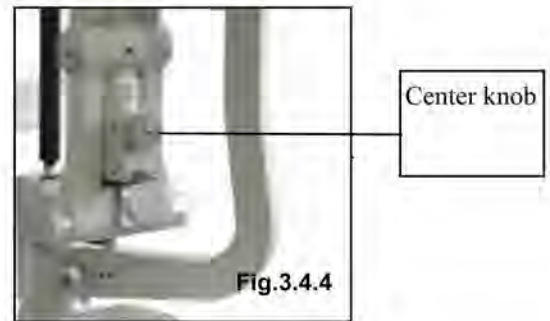

5) Oblique illumination

Oblique illumination is used for sectional or fundus examination by use of a contact lens. Press down the inclination lever so that the illumination part may incline to 20° , (5° of each division). Since the illumination part may touch the patient's head, operate carefully (Fig.3.4.5)



6) Filter selection

By shifting the selection lever four different filters can be inserted into the illumination pathway. Usually the thermal safety filter can make the patients feel comfortable. After using the other filters,

we should turn back to the thermal safety (Fig.3.4.6).

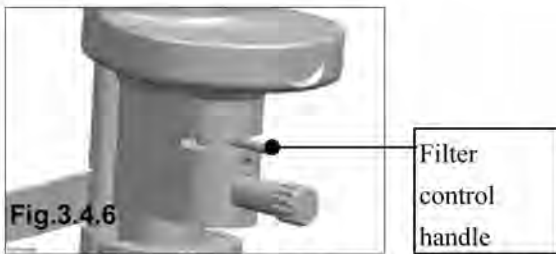

From left to right : No filter, heat-absorption filter, Grey filter, Red-free filter, Blue filter.



The no filter is used for proofreading for the manufacturer.

3.5 Operation notes

1) In the course of the operation the operator should learn more about the contents of the user menu, to master the structure and function of slit lamp microscope so as to carry out the right operation and diagnosis.

2) In order to prevent unnecessary observations arising from the misuse of the judge, operators should observe clearly the different locations in the knob corresponding to a different scale and different directional marks in the process of using the SLM.

3) Operator should adjust the interpupillary distance and diopter correctly in the operating or which may lead a feeling of dizziness

4) Operator may have a feeling of dizziness in long time observing, so please adjust observing time according to personal habit.

5) There will be a branch of crack-ray irradiation in patients' eyes, when they receiving SLM diagnosis. So if the light is too dark, it will affect the observing effect. Conversely, if the light is too bright, in a long time exposure patients' vision might be affected. If patients feel uncomfortable,

please tell the operator or take medical treatment. Therefore, please try to avoid prolonged exposure of patients' eyes in the bright light.

4 Maintenance



Attention: The replaced waste materials should be treated as industrial rubbish.

4.1 Cleaning and maintenance

4.1.1 Cleaning way

① **Cleaning the lens and reflecting mirror:** If any dust stick on the lenses or reflecting mirror, brush them with the brush supplied in the standard accessories. In case any dust still remains, wipe it off with soft cotton dipped with absolute alcohol. (Fig.4.1.1).



Attention: Don't wipe with hands or hard project or any corrosive detergent lest that the surface should be damaged.



② **Cleaning the tie plate, rails and shaft:** If the slide plate, rails and shaft are dirty, the vertical and horizontal movement will be unsteady. Wipe them with clean soft cloth. (Fig.4.1.2).

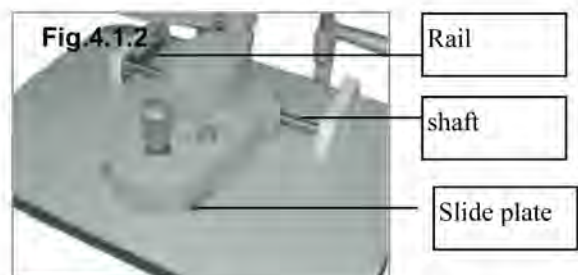

③ Cleaning and sterilizing the plastic parts:

Clean the plastic parts such as chin-rest bracket, forehead-rest belt with soft cloth dipped with soluble detergent or water, then sterilize with medicinal alcohol. **Attention: Don't wipe with any corrosive detergent lest that the surface should be damaged.** (Fig.3.2.1).

4.1.2 The cleaning and maintenance circle of the product

- 1) Clean the eyepieces, objective lens and refractor:

Cycle: suggested once every two months. The lenses are plated with a reflection reducing coating and reflective coating on its surface. Although the coating is hard enough, too frequent wiping will weaken it, which leads to a bad observing optical effect. Two month is a recommendation; if there is lots of dust on the lens, please wipe it immediately.

- 2) Cleaning the slide plate, rails and shaft:

Cycle: suggested once a month

These parts won't get dirty in a clean environment such as hospital in one year. However, we suggest you clean them once every 6 months so that you can get a much better movement effect.

- 3) Cleaning the plastic parts:

Cycle: suggested once a day

These two parts contact with the patients directly, so please clean them timely. Please replace a new and clean chin-rest paper for each patient.

- 4) Cleaning the whole machine:

Cycle: suggested once every two months.

4.2 Protecting

There always are dusts and physiological salt solution dropping into the main shaft hole of the illumination ram during the operation. Please cover the main shaft hole with the

protection cap lest that the instrument would be damaged. Take off the cap when the focus test rod needs to be assembled(Fig.4.2.1).

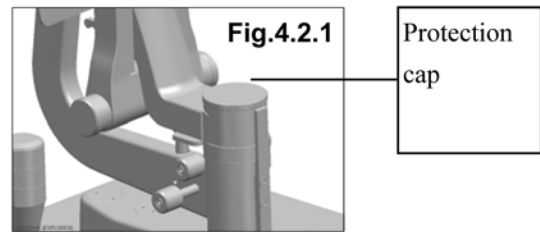

4.3 Adjusting the tightness of the slit width knob

If the slit width control knob is too loose, the slit width may be out of control. Loosen the screw on the right knob with the screw drive, then hold the left knob firmly with one hand, while the other hand rotate the right knob clock-wise to adjust its tightness. When it is appropriate, fasten the screw of the right knob firmly again (Fig.4.3.1).

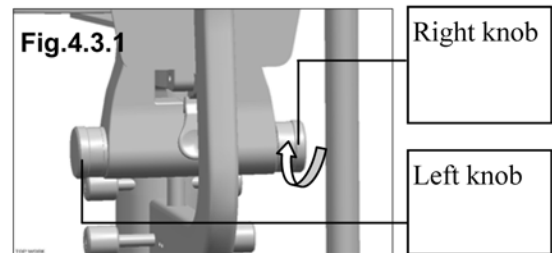

4.4 Adjusting the inclination of the illumination part

If the inclination mechanism of the illumination part is too loose, fasten the screw on both sides of the pivot point with the screw driver. (Fig.4.4.1)

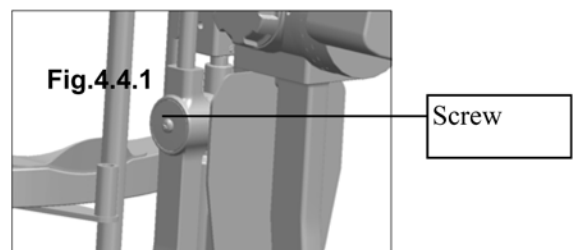

4.5 Replacing the illumination bulb

1. Turn the main power switch off.

(Fig.3.1.3);

2. Pull out the plug attached to the lamp house, remove out the fixation knob. Pull up the lamp cap from the illumination unit. (Fig.4.5.1& 4.5.2)

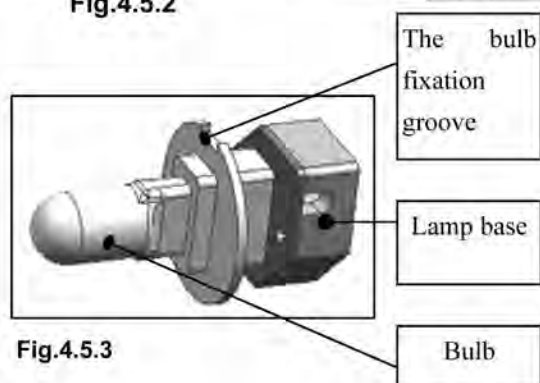
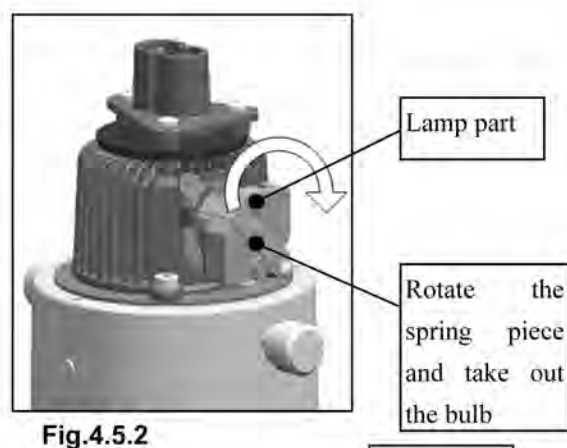

3. Rotate the spring piece clockwise and take out the old lamp part (Fig.4.5.2), replace it with a new one. The groove in the bulb fixation disc should be aligned with the flange of the lamp base; otherwise the illumination may be uneven

(Fig.4.5.3). After assembly the lamp part, turn the spring piece to its original location, and fit the lamp cap on.

4. Place the lamp cap in the original position, fix the lamp cap with the knob, insert the connecting plug.

5. Turn on the main power switch and check whether the new bulb is illuminating. Check the spot to make sure it round and no false light. (Fig.3.1.3)

4.6 Replacing the fuse

1. Turn off the main power switch, and remove the power cable from the socket. (Fig.4.6.1).

2. The fuse is inserted in the fuse box which has fuse mark. Please rotate the fuse part out (Fig.4.6.1) by pressing the fuse box with a screw or a coin. One fuse is in use, the other is in spare. Please check them, if the one in use is burnt, please replace it with the spare one and then place both the two fuse parts into original place.

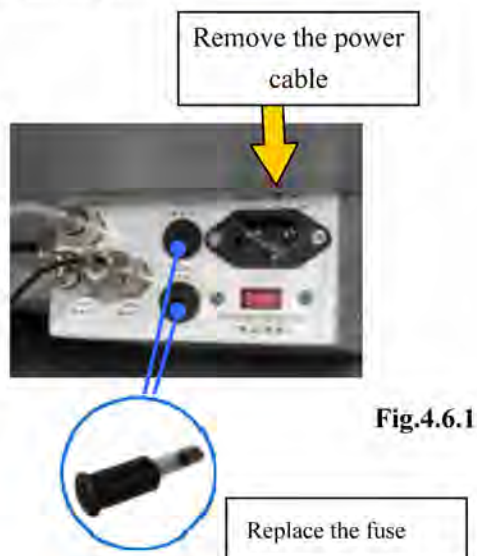

3. The fuse specification:
220V 1A, 250V

⚠ Attention: Please select the fuse of

the same type, specification and rate value.

6V20W halogen bulb: the life span of the bulb is 480 hours; however, it can still work out of the time span though the brightness of the bulb may be lower.

4.7 Replacing the chin-rest paper

When the paper is depleted, pull upward two fixing pins of the chin-rest and place a new package of paper, then fix the fixing pins again. (Fig.4.7.1).

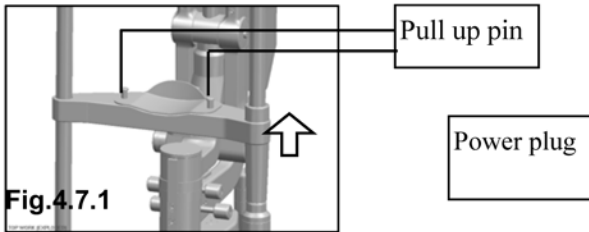

4.8 Consumables

Fuse: 1A/250V 1 piece
 Bulb: 6V20W1 piece

5. Trouble shooting guide

In case there is any trouble, please check according to the following table for reference. If it still cannot work, please contact the authorized distributor.

Trouble	Possible cause	Remedy
No illumination	The cable isn't connected correctly with the power socket	Connect the power cable correctly
	The main power switch is on 'O' position	Place the switch on 'I' position
	The plug on the power box is loosen	Insert the plug firmly
	The plug on the lamp cap is loosen	Insert the plug firmly
	The bulb has burnt out	Change the bulb
	The fuse has blown	Change the fuse
	The bulb is not assembled properly	Assemble the bulb properly
	The filter lever is in the middle position or in the position of gray filter	Set the filter lever to the correct position
	the brightness adjustment knob is at min.	the brightness adjustment knob
Slit is too dark	Voltage selector is wrongly set	Set the voltage selector correctly
	The coat of the reflecting mirror is oxidized	Change the reflecting mirror
	Too much dust on the reflecting surface	Clean the surface with the brush
Fuse has blown	Voltage selector id wrongly set	Set the voltage selector properly
	The fuse doesn't comply with the specification	Replace it with a suitable fuse
Slit width closes automatically	The slit width control knob is too loose	Adjust the tightness of the control knob
Fixation bulb is off	The output plug is loose	Insert the output plug firmly

Appendix A

Electronic Circle Drawing

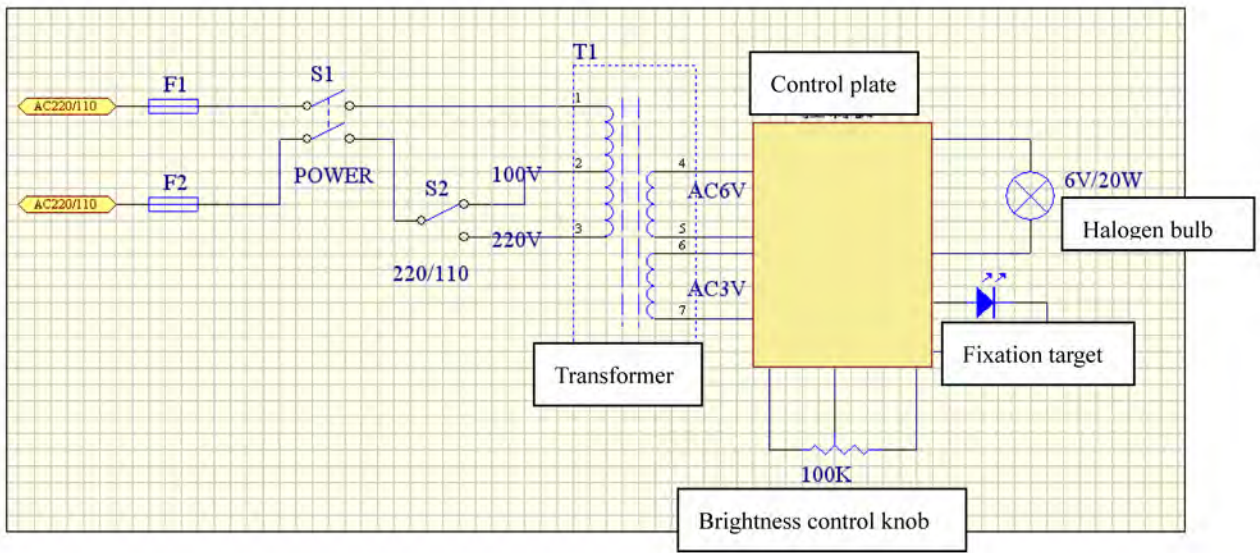

Appendix B

Illustration of the board of power box:



1. Fuse box
2. Power socket
3. 110V/220V voltage selector
4. Fixation lamp socket
5. Illumination lamp socket
6. Brightness control knob socket

Assembly of power supply:



1. Please connect the slit lamp with power supply (as fig. 1 shows). Refer to Fig.2, take out the link wire of brightness control knob inside the base and connect it to the corresponding socket on the power box. Refer to Fig.3, insert the plug of chin-rest bracket in the correct socket, and fasten it.

 **Caution:** Make sure the main power plug is not connected.

2. Check the voltage selector, this power box support working under the voltage of 110V and 220V. Please select the right voltage according to the voltage in your country.

 **Caution:** Wrong power selection may lead to damage of the instruments.

3. Open the fuse box and make sure there is a fuse assembled (as Fig,4 shows).

Specification of the fuse: 1A/250V

4. Insert the main power cable and turn on the switch. Referring to the instruction of brightness control knob, the brightness of the bulb is adjustable.
5. Please do unplug all the cables connected between slit lamp and the power box when moving the slit lamp to a new place, in case there is any danger caused.

Subject to change in design or specifications without advance notice

VIEWLIGHT™
POWERED BY INNOVATION

8380 NW 64 St.
Miami, FL 33166 USA
Tel: 305-406-3915
Email: customerservice@viewlightusa.com
Web: www.viewlightusa.com