

CLINICAL SLIT LAMP
MANUAL



CSL-10U

Content

Preface.....	2
Chapter 1 Summary.....	3
1.1 Machinery description.....	3
1.2 Usage information.....	3
1.3 Structure components.....	5
1.4 Applicability.....	5
1.5 Points for attention.....	6
1.6 Product features.....	6
1.7 Symbolic interpretation.....	6
1.8 Product label (Sample).....	7
Chapter 2 System Introduction.....	8
2.1 External view —slit lamp.....	8
Chapter 3 Installation.....	10
3.1 Working Environment.....	10
3.2 Open - package inspection.....	10
3.3 Hardware installation.....	11
3.3.1 Installation Environment.....	11
3.3.2 Installation instruction.....	11
Chapter 4 Operation step.....	15
4.1 Preparation for Diopter Compensation and PD Adjustment.....	15
4.1.1 Usage of the focus rod.....	15
4.1.2 Brightness adjustment.....	15
4.1.3 Diopter Compensation.....	15
4.1.4 PD Adjustment.....	16
4.2 Position of the Patient and the usage of fixing lamp.....	16
4.2.1 Fixed position of patient head.....	16
4.2.2 Usage of the fixation lamp.....	17
4.3 Operation of the Pedestal.....	17
4.4 Operation of the illumination Component.....	18
4.4.1 Change the slit image.....	18
4.4.2 Slit flip.....	18
4.4.3 Diverge the illumination light.....	19
4.4.4 Tilt the light.....	19
4.4.5 Reflector.....	19
4.4.6 Choose filters.....	20
Chapter 5 Maintenance.....	21
5.1 Equipment interference sources.....	21
5.2 Maintenance.....	21
Chapter 6 Transpotation and storage.....	24
Chapter 7 Common Faults.....	25
Chapter 8 Declaration.....	26

Preface

Dear Users:

We would like to thank you for your decision to purchase this slit-lamp microscope manufactured by us.

We feel deeply honored to get your trust. The instruction including the installation, usage, notice for use, maintenance, transportation and storage.

For your security and benefit, please read the <Operation Instruction> as well as all the datum of the instrument carefully before using it.

If the instructions in this manual are carefully followed, we are confident that this product will give you reliable and trouble-free usage.

Please check following accessory before your using:

- 1、 Please ensure the instrument accessories consistent with the packing list;
- 2、 Please read random files carefully and keep properly.

The pictures in instruction only for your reference purpose.If you have any questions, please feel free to contact our distributor in your area,or directly to us.

Chapter 1 Summary

1.1 Machinery description

The slit lamp is essentially a simple and generally under-used piece of equipment. It consists of an illumination system and a binocular observation system. It's intended for use in eye examination of the anterior eye segment, from the cornea epithelium to the posterior capsule. It is used to aid in the diagnosis of diseases or trauma which affect the structural properties of the anterior eye segment.

Indication for use: AC-powered slit lamp Bio-microscope intended for use in eye examination of the anterior eye segment, from the cornea epithelium to the posterior capsule. It is used to aid in the diagnosis of diseases or trauma which affects the structural properties of the anterior eye segment.

1.2 Usage information

1.2.1 For your security and benefit, please read the <Operation Instruction> carefully before using it. If you do not operate the instrument according to the Operation Instruction, we shall not take any responsibility.

1.2.2 Use it in darkroom environment.

1.2.3 This device can be used near patient.

1.2.4 The voltage must be up to the given standard. If the voltage is not steady, please install a Constant Voltage Regulator. We will not take responsibility for the damage caused by the voltage.

1.2.5 Do not use in the inflammable, hot, dusty and oxygen-enriched environment and pay attention to keep it clean and dry; To avoid being damaged by the environment (Damp, Dusty, Liquid, under the sun and so on). Do not let the liquid or any other small objects run into the instrument, otherwise these objects may make the inner parts of the instrument short-circuit, and even make the users get an electric shock or even cause a fire hazard.

1.2.6 Waterproof grade IPX0. Durable life of 6 years.

1.2.7 Without the permission of us or our authorized distributor, do not open the box of the instrument or we will not take the consequences.

1.2.8 For better maintainance, please wait for at least 5 seconds to restart the

device after turn off.

1.2.9 All components and parts of the device can not be disassemble

1.2.10 Do not touch the surface of lens with hand or hard objects.

1.2.11 Install this instrument on the ground where the dip angle is less than 2 degree to avoid toppling over

1.2.12 Choose the cartridge fuse meeting our requirement.

1.2.13 Turn off the main power before replacing the LED module and the cartridge fuse.

1.2.14 Turn off the power and cover it with dust guard when you do not use it ;
If the equipment is not being use and for long-term storage, set up an electric circuit for slit lamp Three times a week, at least 4 hours each time.

1.2.15 The main medical electrical equipment is slit lamp, optics body and platform.

1.2.16 Check the firm cable joints. The earth cables on the Motorised table and the power box must be connected well by the grounding wire.

1.2.17 Environmental protection clause: It will pollute the environment if you discard the equipment and the accessories which is breakdown, recall or disposal according to the local laws and regulations.

1.2.18 Operator should inform patient to watch their hand pinching by slit lamp while base moving.

1.2.19 The spectrum of light source used in slit lamp

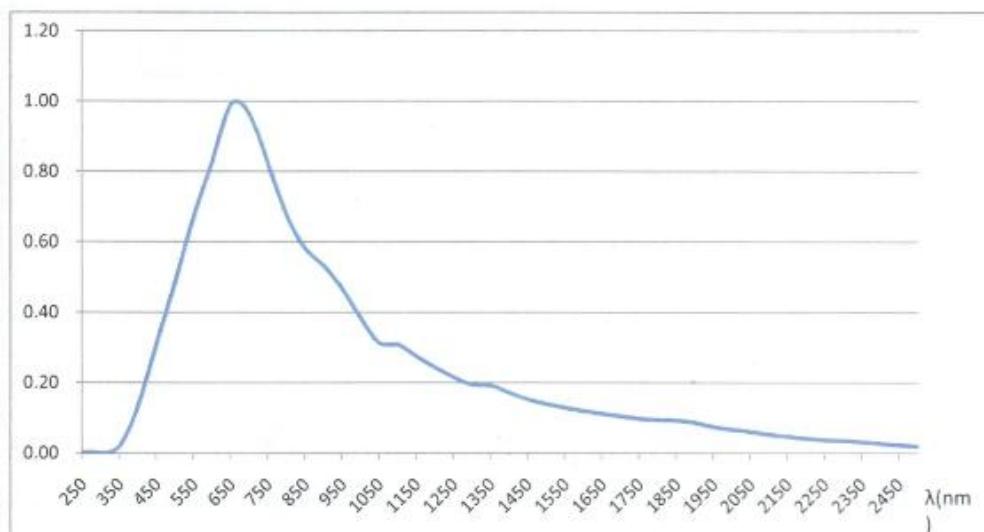

1.2.20 Cautionary Statement

Caution-The light emitted from this instrument is potentially hazardous. The longer the duration of exposure, the greater the risk of ocular damage. Exposure to light from this instrument when operated at maximum intensity will exceed the safety guideline

after 170 seconds.

1.2.21 The Maximum brightness of LS slit lamp is 300000lux, and it's continuously brightness control.

Brightness controller	0	25%	50%	75.00%	100%
Brightness (Unit: Lux)	8959	64096	178447	271833	300000
Permissible error	±5%	±5%	±5%	±5%	+10%

1.2.22 This device conforms to following standards: IEC60601-1: 2005 Medical Electrical Equipment-Part 1: General requirement for safety; IEC60601-1-2 Medical electrical equipment - Part 1-2: General requirements for basic safety and essential performance - Collateral standard: Electromagnetic compatibility - Requirements and tests, Edition 3:2007; ISO 15004-2:2007 Ophthalmic Instruments - Fundamental requirements and test methods Part 2: Light hazard protection and ISO 10939:2007 Ophthalmic Instruments- Slit Lamp Microscopes.

1.2.23 Caution: In order to avoid the risk of electric shock, the system should connect to power supply network only with protective earthing.

1.2.24 In order to ensure that the power supply can be disconnected quickly when the product fails, do not place the power plug in a difficult place to disconnect

About the instruction:

1.If it breaks down, please read the guide to fix the breakdown. If it does not work yet, please contact us.

2.We have the right of interpreting and revising this operation instruction.

1.3 Structure components

It's mainly structure by: illumination part, binocular microscope, headrest, pedestal, operation platform.

1.4 Applicability

For inspecting the illness of anterior segment and intraocular part.

1.5 Points for attention

Caution: Federal law restricts this device to sale by or on the order of a physician or licensed professional practitioner.

1.6 Product features















Equipment safety class I

Application part Type B

The instrument is continuous operation working form

Fusing parts: T2AL 250V

1.7 Symbolic interpretation

	Application part Type B		Dangerous Voltage
	Read instruction manual carefully		Power off
	Power on		Alternating current
	Direct current	ON	Power on
	Direct current	OFF	Power off
a.c.	Alternating current		
	Manufacturer		Date of Manufacture
	Recyclable		European certificate of conformity
	Check the instruction manual		Series Number of products
	Authorized representative in the European Community		

1.8 Product label (Sample)

VIEWLIGHT
POWERED BY INNOVATION

Clinical Slit Lamp

SN VL-539812502
Power consumption: 70VA
INPUT: 100-240V~ 50/60Hz

Viewlight LLC **CSL-10U**
8380 Nw 64 St Miami Fl 33166,
United States Of America

 04/2020

WWW.VIEWLIGHTUSA.COM

CE

Chapter 2 System Introduction

2.1 External view –slit lamp

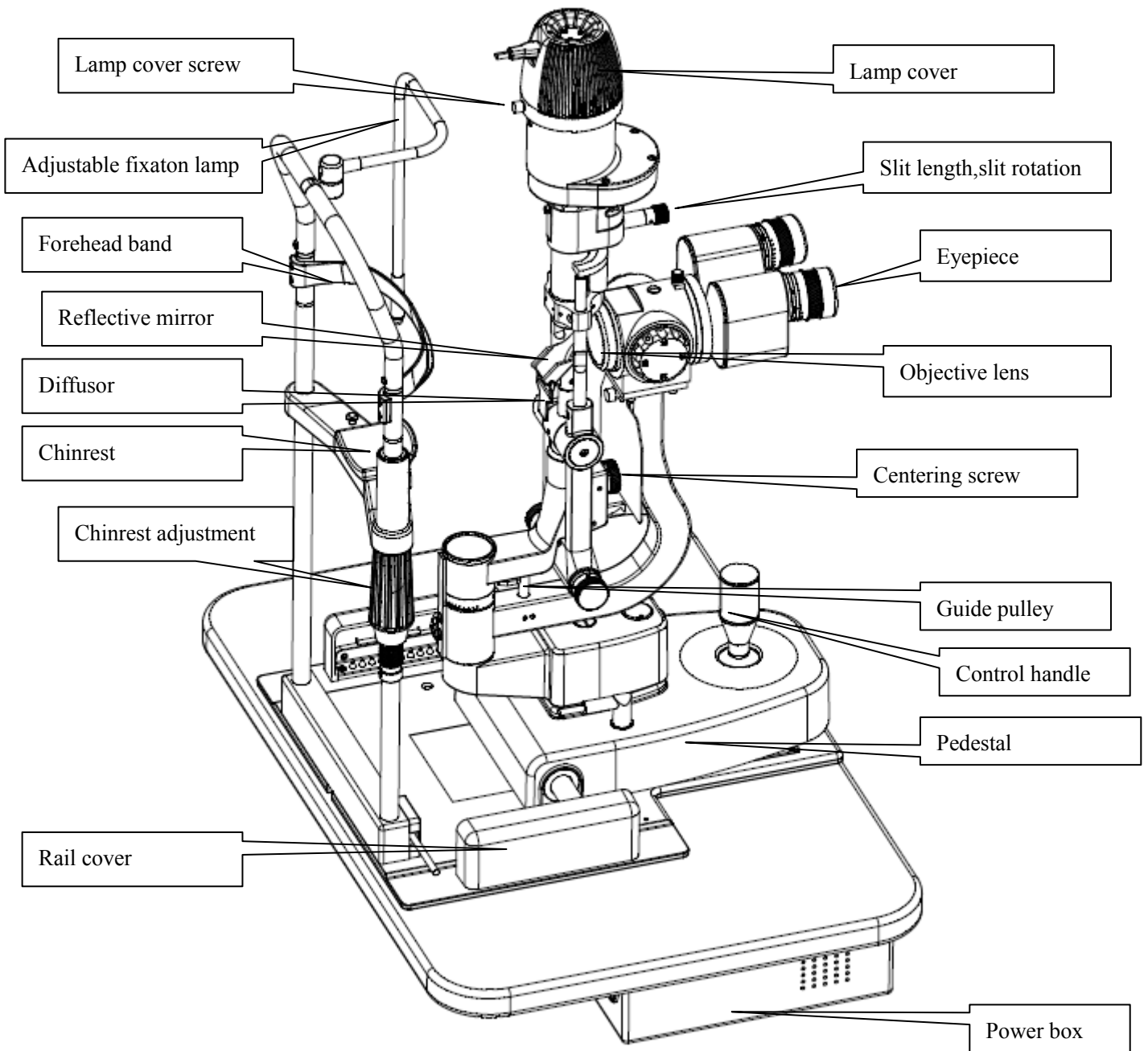

Picture 1(front view)

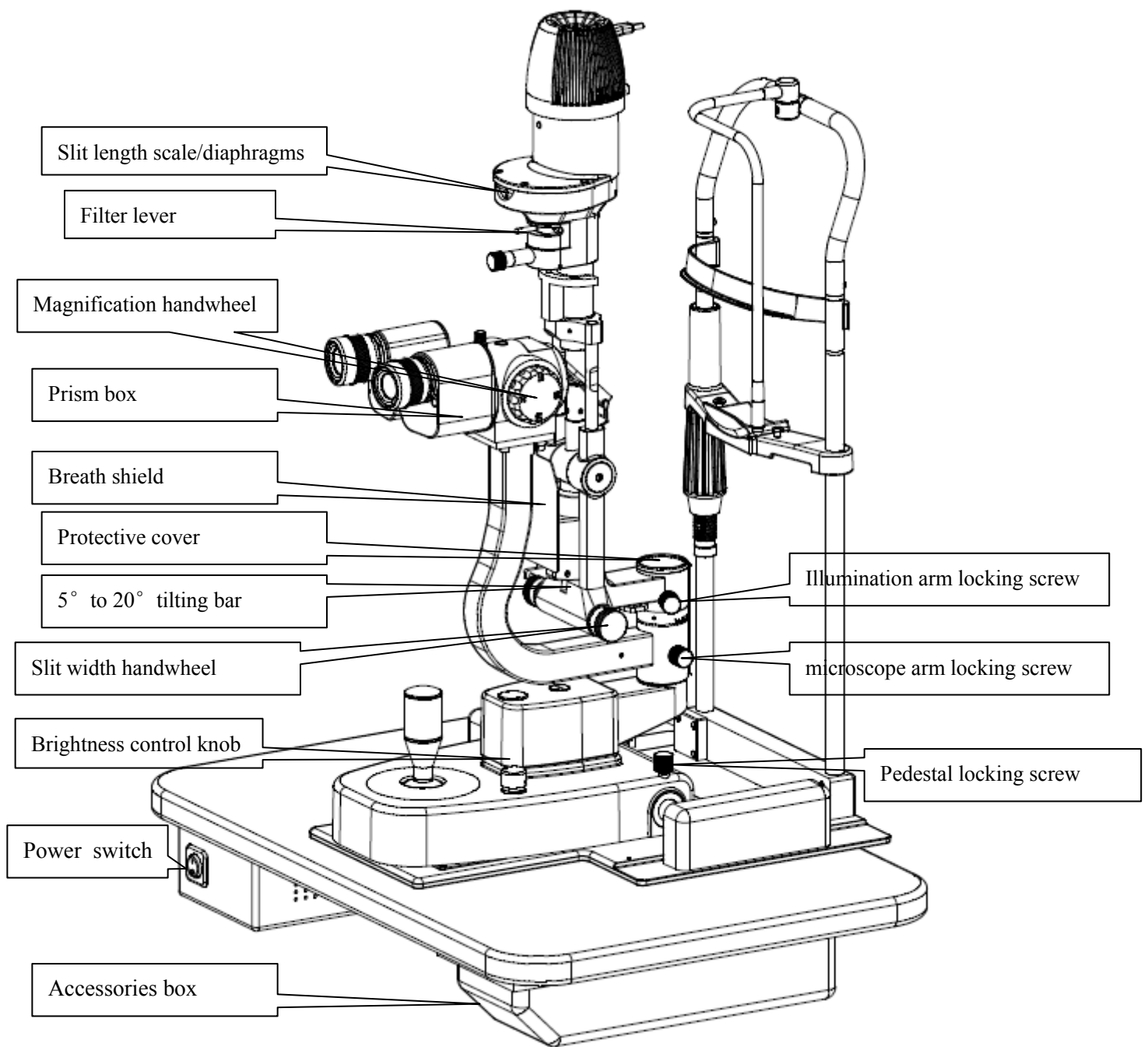

Picture 2 (side view)

(Please comply with the actual instrument cause there may have modification)

The composition of components patient body may touch:

Forehead band & chinrest → ABS Engineering Plastics

Remark: Magnification-Changing Knob → 3 step magnification: 10X、16X、25X

5 step magnification: 6X、10X、16X、25X、40X

Chapter 3 Installation

3.1 Working Environment

3.1.1 Environment temperature: 5 °C~40

to: 85% relative humidity

3.1.2 Atmospheric pressure: 500hPa~1060hPa



3.1.3 Power: a.c.100~240V 50~60Hz

3.1.4 Input power: 70VA

3.2 Open - package inspection

3.2.1 Make sure the instrument have not been hurt or loss during transpotation after open the package.

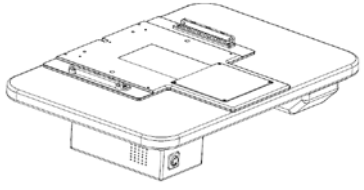
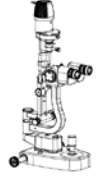
Slit lamp microscope configuration list

Part name	Quantity	Remark
Lifting Table(Optional part,deliver only when ordered)	1pc	
Portable metal table top (optional) PS:Wooden table top is a Optional part, deliver only when ordered	1pc	
Binocular microscope with pedestal and Illumination system	1pc	
Head bracket(forehead band & chinrest)	1pc	
Power wire	1pc	

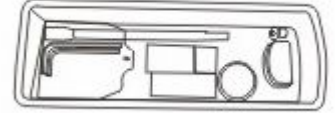
Instruction manual	1pc	
Accessories(Focusing rod,Jaw paper, Protective cover, short reflector, breath shield, inner hexagon wrench etc.)	1pc each	

3.3 Hardware installation

3.3.1 Installation Environment

In order to ensure the safe and stable operation of the equipment, please ensure the installation environment.

3.3.1.1 Install this instrument on the ground where the dip angle is less than 2 degree to avoid toppling over;

3.3.1.2 This equipment must be installed in clean, quiet and dry environment.

3.3.1.3 Install it in a absolute darkroom.

3.3.2 Installation instruction

This instruction is appropriate for installing the slit lamp. Take all the components out carefully from the packing box and then fix them (Tool needed: Phillips screw screwdriver, inner hexagon wrench) .

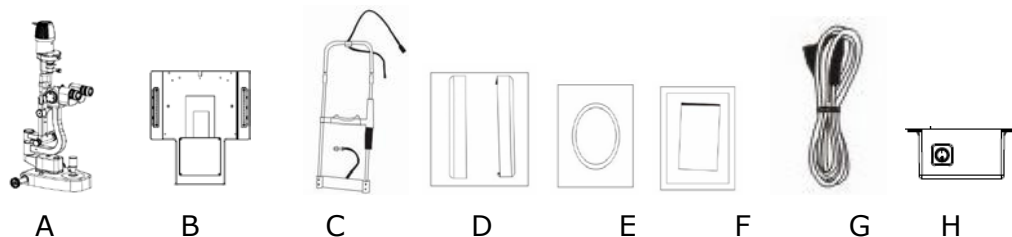

Picture 3

Code	Part name	Quantity
A	Binocular microscope with pedestal and Illumination system	1

B	Portable table top	1
C	Head bracket(head rest & chinrest)	1
D	Rail Cover	2
E	Protective cover	1
F	Short reflector	1
G	Power wire	1
H	Power supply box	

3.3.2.1 Install the Workbench

Please use the solid wrench to screw out the four M8 X 20mm bolts with spring washers on the workbench.

- Lift up the workbench; Make the screw apertures on the fixing holes of the instrument.
- Put the workbench down. Let the board for controlling power face the operator. Put the bolts into the screw holes again and then use the wrench to fasten the bolt.

3.3.2.2 Install head bracket component

- Put the portable table top on the auto table.
- Screw the four screws under the fixing board of the head bracket with the screw driver.

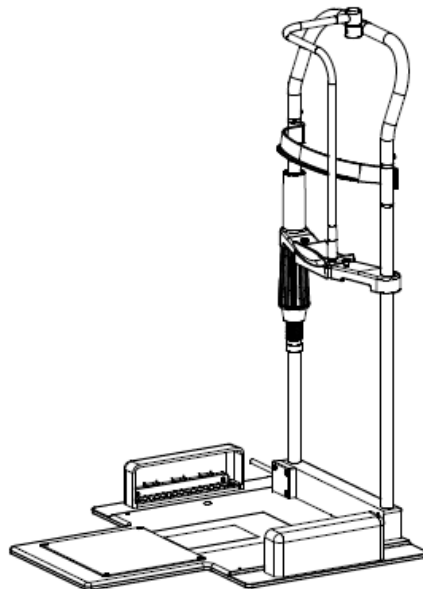

Picture 4

3.3.2.3 Install the microscope pedestal and rail covers.

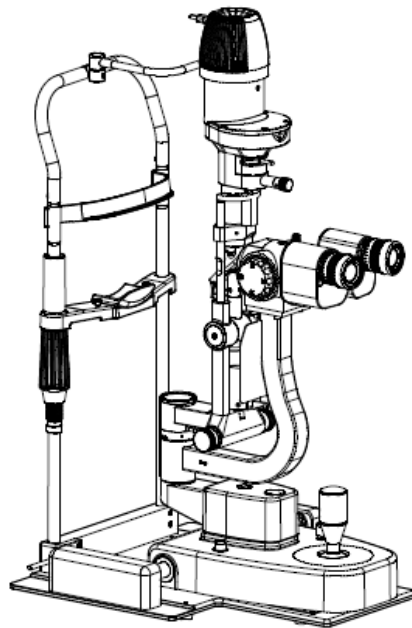

Picture 5

- Put the axle of the pedestal on the guide rail of the work-bench.
- Install the 2 rail covers by pressing them into the holes on guide rails.

3.3.2.4 Take off the Cushion.

- The function of the cushion is to prevent slitting component from damage when transporting the microscope.

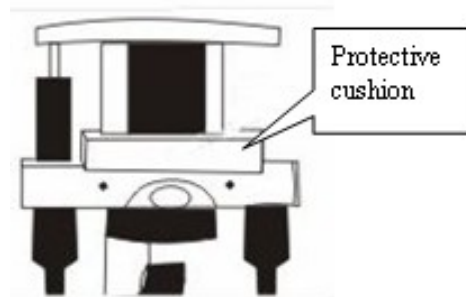

Picture 6

3.3.2.5 Joint the Plug

- Insert the plug of power wire and the 2 cables from the chinrest and pedestal into the matched sockets on the power box.

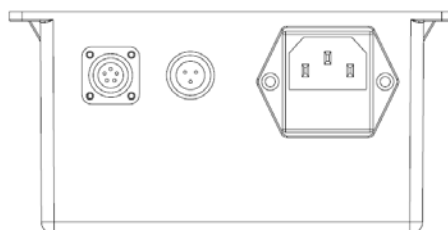

Picture 7

3.3.2.6 Insert the lamp cable

Insert the double-core plug on the headrest into the matched sockets (Picture 8)

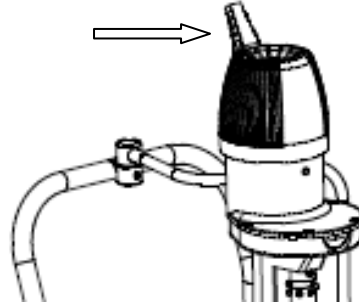

Picture 8

3.3.2.7 Drawer can keep preset short reflector, focusing rod and some other accessories.

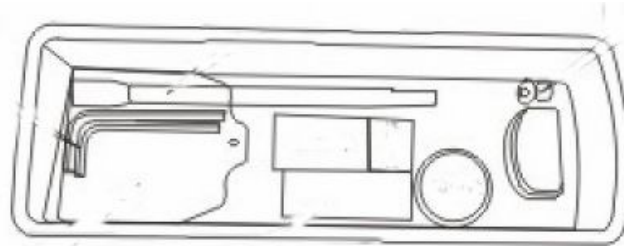

Picture 9

Chapter 4 Operation step

4.1 Preparation for Diopter Compensation and PD Adjustment

This step must be carried out before using the slit lamp for checking.

4.1.1 Usage of the focus rod

As a standard accessory, focus rod is provided to ensure right adjustment of the microscope. Insert the focus rod into the hole of main axle and make the planeside direct to the objective lens of the microscope (the side of the operator)

Note: Take out the focusing rod after adjustment.

4.1.2 Brightness adjustment

- ✧ Turn on the main power, the indicating lamp will turn green. This device has 3 step brightness control, it can be carried out by turning the brightness controlling knob.
- ✧ Rotate the slit length controlling knob till the slit length diaphragm shows 14mm. Then rotate the slit width controlling knob till maximum.
- ✧ Move the pedestal roughly by joystick to make the beam on the focusing rod
- ✧ Accurately adjust the pedestal vertically and horizontally by joystick till you see the clearly 1-2mm slit image on the focusing rod

4.1.3 Diopter Compensation

The focus of the microscope is adjusted as the hemitropic. If the operator is not emmetropic, the diopter must be adjusted. (for example: myopic 100 degrees, the diopter should adjust to -1 position).

We recommend you to rectify diopter according to the following steps

- ✧ First of all, turn the ring adjusting diopter to its end counter-clockwise ;
- ✧ Look through the eyepiece and rotate the eyepiece ring in clockwise direction till you can see the image of the focusing rod clearly (Picture 10)
- ✧

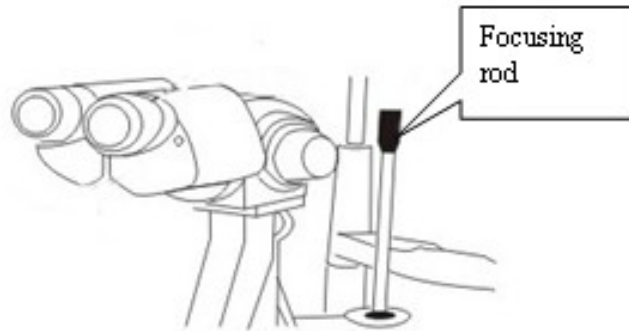

Picture 10

4.1.4 PD Adjustment

Adjust the prism boxes(hand pull), make the eyes can see the image on the focusing rod together and get the stereoscopic image. For the binocular has linkage function, So two eyepiece remain on the same horizontal line(Picture 11)

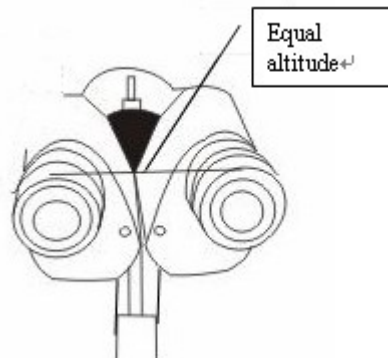

Picture 11

4.2 Position of the Patient and the usage of fixing lamp

4.2.1 Fixed position of patient head

Place the patient's head on the chinrest, making the forehead of the patient nestled closely to the ribbon for forehead bracket. Adjust the chinrest height-controlling handle under the chinrest until the eye of the patient is on its best place.

4.2.2 Usage of the fixation lamp

To fix the sight of the patient, let the patient's non-inspecting eye look at the fixation lamp. If the position of the lamp needs to be changed, you may move the handle of the lamp or move the curved handle around the head bracket

4.3 Operation of the Pedestal

4.3.1 Rough adjustment horizontally

Keep the joystick vertical, move the pedestal to make the microscope move on the horizontal plane so as to make the microscope roughly directly toward the target (Picture 13)

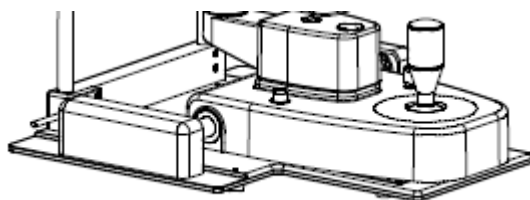

Picture 13

4.3.2 Accurate adjustment horizontally

Tilt the joystick in all sides to make the microscope move slightly on the horizontal plane. Adjust and view through the eye lenses at the same time to get clearest image

4.3.3 Accurate adjustment vertically

Rotate the joystick to adjust the height of the microscope so as to make the microscope be flush with the target. Turn the handle clockwise to make the microscope rise, turn the handle counter-clockwise to make it fall.

4.3.4 Lock the pedestal

Tighten the locknut for the set to fix the pedestal after adjusting well, make it can not remove.(This must be carried out when transport the slit lamp)

4.4 Operation of the illumination Component

4.4.1 Change the slit image

Changing the slit width and slit length by controlling knob.

Change the width of the slit image

Turning the knob controlling the slit width, you can make the slit width change from 0mm to 14mm (when the width is 14mm, the slit will become round).The graduations on the knob indicate the rough value of the slit width.

Change the aperture and slit height

Rotate the aperture and slit height adjuster knob,you can get 6 different sizes of lighting dots. The diameter can be 14mm,10 mm,8 mm,6 mm,4 mm,2 mm,1 mm & 0.2 mm respectively.When observing the slit image,the height an be changed from 1mm to 14mm in succession and its figure can be read in the slit length scale(Picture 14)

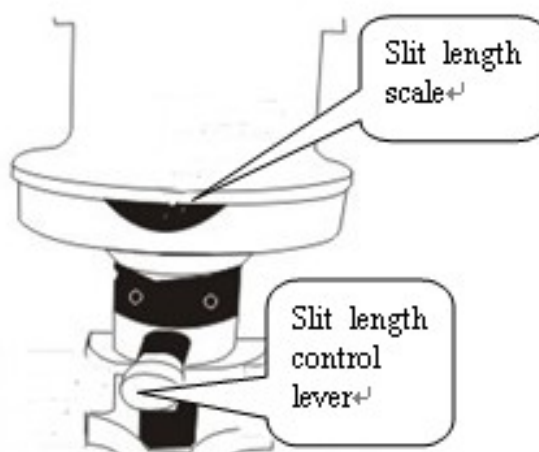

Picture 14

4.4.2 Slit flip

Rotate the upper part of the illumination part horizontal,the slit can flip any desired angle.

4.4.3 Diverge the illumination light

Loosening the centering screw will allow the slit image to be moved off centre for scleral illumination. Tightening the screw will re-centre the slit image in the visual field of the microscope. (Picture 15)

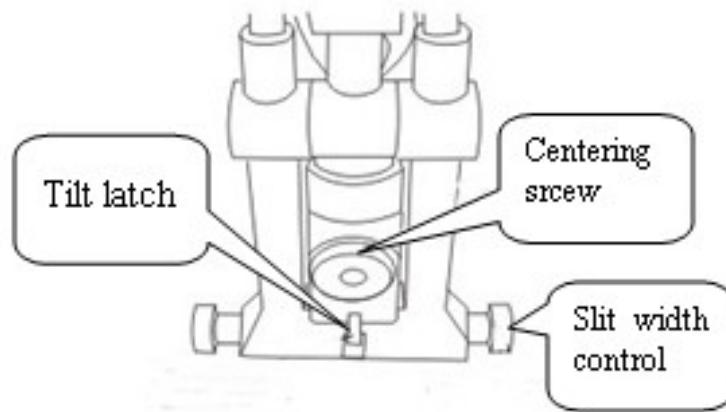

Picture 15

4.4.4 Tilt the light

When you use the contacting lens and meanwhile use the section of the slitting light, you must tilt the light. When pressing the tilting handle for lighting, the lighting component can tilt to 20 degree (5 degree per grade). Be careful when you use this method because the instrument may touch the head of your patient

4.4.5 Reflector

This instrument has two reflectors. One is long and the other is short. We usually use the long reflector. When the included angle between the lighting component and the microscope is between 3 degree and 10 degree, the image may be obstructed. Then you can use the short reflector. (Picture 16)

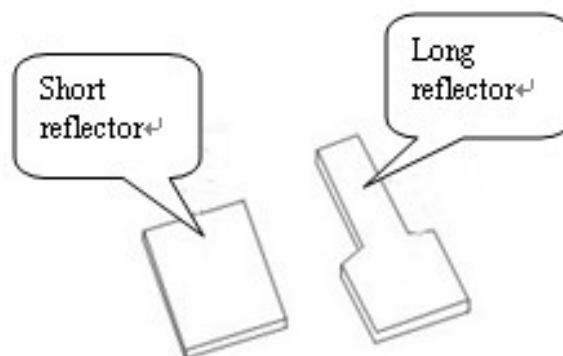

Picture 16

4.4.6 Choose filters

Moving the filter-choosing handle on the horizontal plane, you can change four different color filters in the lighting way. The heat filter is usually used so as to make patients feel more comfortable.(Picture 17)

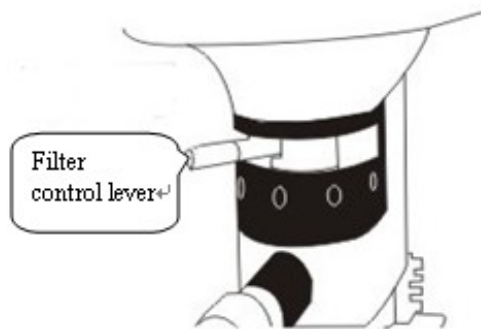

Picture 17

1. No filter
2. Heat absorption filter
3. Grey (ND) filter
4. Red free (green) filter
5. Cobalt blue filter

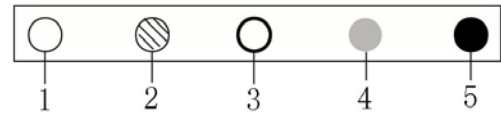

Chapter 5 Maintenance

In order to obtain better use effect and longer life,environment without interference and correct maintenance method is very necessary.

5.1 Equipment interference sources

Please avoid or keep away from the following sources or to take isolation measures during the machine operation and production:

5.1.1 The large power electrical facilities, high power wireless transceiver equipment such as big transformer and communication station;

5.1.2 Moving Vehicle,airplane and big mechanical equipment will interfere with equipment.

5.1.3 Other medical instruments,especially the radio equipments;

5.1.4 Other human or natural electromagnetic interference which can't be avoid,such as solar activity and cosmic radiation.

5.2 Maintenance

5.2.1 The objective lens must be in a dry, clean condition,do not touch the surface of reflector lens and the objective lens with hand or hard objects. If there is besmirch on the lens or reflector, use absorbent cotton with a little absolute alcohol to clean.

5.2.2 Keep the room clean, airiness and dry, and use air-conditioner as possible.

5.2.3 If the equipment is not being use and for long-term storage, set up an electric circuit for slit lamp Three times a week,at least 4 hours each time.

5.2.4 If it breaks down, please read the guide to fix the breakdown. If it does not work yet, please contact us or our authorized distributor.

5.2.5 Disinfection of chinrest:use absorbent cotton with a little absolute alcohol to clean and disinfect.

5.2.6 Turn off the power and cover it with dust cover when you do not use it.The dust on the body surface and the surface of the mirror should be cleared in time.

5.2.7 Replace the LED module

- Turn off the main power switch;
- Take out the power wire plug. Screw off the fixing screw of lamp cover and take out the lamp cover;
- Lose the 4 screws around the LED module base which is fixed the LED module on

Illumination arm, take the old LED module off and replace the new on, fix the 4 screw back.

- Put the lamp cover to the original place, fastens with screw, and connects the plug;

Pictures for reference only, subject to our products. We reserve the right to change the product without prior notice !

5.2.9 Replace the reflector

- Make the angle between the microscope arm and the illumination arm bigger than 30 degree;

- Tilting the illumination arm more than 10 degree

- Hold the projection of the long reflector and pull out the reflector(Picture 18)

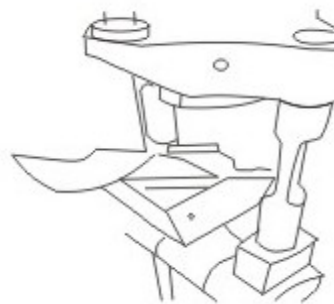

Picture 18

- Insert new long reflector or short reflector ;

- When replacing the short reflector, you can use an object with a tip to push the underpart of the show(Picture 19)

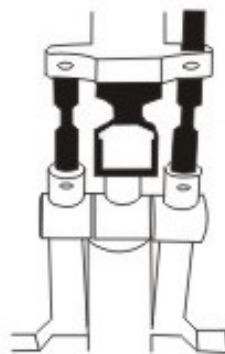

Picture 19

5.2.10 Replace the fuse:

 Disconnect the power of the equipment, unscrew the fuse cover, and changing a new one and recover the fuse cover.

5.2.11 Adjustment of friction of the slit width control

If the knob for controlling the slit width is too loose, the slit width may be out of

control. Loosen the screw on the right knob with the screwdriver, then hold the left knob with one hand and turn the right knob clockwise with the other hand to adjust the tightness to proper degree. After getting the suitable degree of tightness, fasten the screw on the right knob(Picture 20)

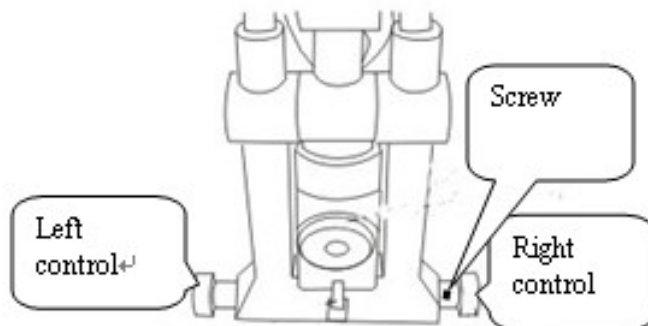

Picture 20

5.2.12 Adjust the tilting action of the illumination component

If the tilting part on the lighting component is too loose, fasten the screws on the fulcrum of two sides with the screwdriver.

5.2.13 Cleaning

5.2.13.1 Clean the lens and reflectors

If the lens and the reflectors are dusty, use the lens paper in the standard component to clean them. If they are still dusty, use the soft cotton swab stained with absolute alcohol to wipe them up slightly.

Note: Do not wipe the lens and reflectors with fingers or hard object.

5.2.13.2 Clean the sliding plate,guide rail and the axle

If it becomes difficult to move the slit lamp around on the gliding plate, the plate should be cleaned with a slightly oily rag. After removing the rail covers, the rails should be cleaned with a stiff brush.

Clean only with dry, lint-free cloths! (Picture 21)

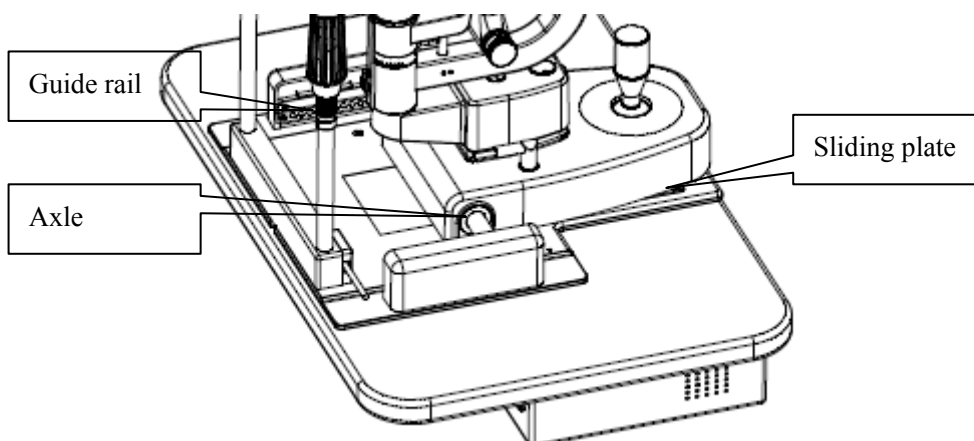

Picture 21

5.2.13.3 Clean and disinfect the plastics components

Use a piece of soft cloth stained with dissolvable cleanser or water to clean the plastics components such as the chinrest and ribbon for forehead bracket and disinfect them with medicinal alcohol.

Note: Do not use any corrosive cleanser to wipe them, or the surfaces would be damaged!

5.2.14 Protection

In the using course of the slit-lamp, the hole of main axle may have dirt, such as dust and physiological saline in it. In order to prevent the instrument from damage, please cover the hole of main axle with the protecting cap. Take off the cover when necessary to install the leading board.

5.2.15 Consumable

Please indicate the names and amount clearly when order these objects (Should use the designated objects by us, or we will not take the consequences.)

Products	Names of components	Remark
Slit-lamp	Illuminating source	LED
	Long reflector	---
	Fuse (T2AL 250V)	

Chapter 6 Transpotation and storage

6.1 Prevent the instrument from damp, inverting and shaking violently during transpotation.

6.2 Keep it in the room in which the relative humidity is less than 85 percent; the ambient temperature is between -15 degree and 40 degree and air pressure is between 500hPa and 1060hPa and well ventilated without corrosion gases.

6.3 If the installed instrument needs to move or transport in short distance, all the moving components must be locked. Please support with your hands on its rear and push or lift it carefully. If the instrument must be transported in long distance, re-pack it into its package for transporting it.

Chapter 7 Common Faults

Breakdown	Possible cause	Treating ways
Illuminating dose not work	The power wire dose not link to the electric socket correctly	Link the power wire correctly
	Main power switch is on "0" position	Turn the switch to "1" position
	The plug on the power box is loose	Fasten the plug
	The jointing plug of lamp cover loosen	Fasten the plug
	The LED is burn down	Replace LED module
	The fuse is fused	Replace the fuse
The slit is too dim	The light filter handle directs the first grade or intermediate position of the light filter	Turn the choosing handle to the right position
	The surface of the reflector oxidized	Replace the reflector
	The reflector is covered by too much dust	Clean the surface of the reflector with the lens paper
	Surface polishing of the reflector	Clean the surface of the reflector with the soft cotton
	The protector of the microscope or the lens' surface is stained	Clean the surface of the lens
	The LED illumination parts failed	Replace it
The fuse breaks	The type of the fuse is wrong	Replace the proper fuse
	The joint of the electric wire is loose	Fasten the joint of power wire
The slit shuts off automatically	The slitting width controlling knob is too loose	Adjust the degree of tightness of the knob
The sight fixing lamp dose not work	The output plug of the power box is loose	Fasten the plug
	The switch of power box is turn off	Turn on the power box

Chapter 8 Declaration

We can provide you the information of consumable.

1. We will provide enquiry free for one life.
2. We are not responsible for
 - Take apart or amend the instruments without the permission of us, which cause damage;
 - Any damage caused by fire, earthquake, third party's action, any other accident or user's intentional or unintentional error, abuse or use under abnormal conditions;
 - Any damage resulting from disobedience of what is described in the instruction manual;and
 - Any damage resulting from, for instance, malfunctioning of the instrument caused by a combination of connected devices.

