

**AUTOREFRACTOR & KERATOMETER**

# MANUAL





## Table of Contents

<b>1. IMPORTANT NOTICE</b> .....	<b>1</b>
1.1 Intended Use.....	1
1.2 Classifications.....	1
1.3 Caution.....	2
<b>2. SAFETY</b> .....	<b>3</b>
2.1 SAFETY INFORMATION .....	3
2.2 Symbol Information .....	4
2.3 Shape Of Plug .....	5
2.4 General Safety Information .....	6
2.5 Cautions in Installation , Storage and Transportation.....	7
2.6 Patient environment .....	8
2.7 Labels.....	9
<b>3. Features</b> .....	<b>10</b>
<b>4. Notes for Using the Instrument</b> .....	<b>11</b>
<b>5. Prerequisites for safety</b> .....	<b>13</b>
5.1 Preparation before use.....	13
5.2 Preparation when you use.....	13
5.3 Instruction and operation sequence.....	13
5.4 Storage after use.....	13
<b>6. Introduction</b> .....	<b>14</b>
6.1 Front side of body.....	14
6.2 Back side of body .....	15
6.3 Bottom side of body .....	16
6.4 Plugging .....	17
6.5 Release stage fixing .....	17
6.6 Engage printing papers .....	17
<b>7. GUI(User Interface)</b> .....	<b>18</b>
7.1 Main Dialog .....	18
7.2 ILLUM Dialog .....	20
7.3 KP Dialog .....	21

7.4 KP-Ker Dialog .....	22
7.5 KP-ECC Dialog .....	22
7.6 KP-Diop Dialog .....	23
7.7 Size Mode.....	24
7.8 Display Dialog.....	25
<b>8. Setting Dialog – Display.....</b>	<b>26</b>
8.1 Setting Dialog-Measure .....	27
8.2 Setting Dialog-System .....	28
8.3 Setting Dialog-Date .....	29
8.4 Setting Dialog-Print .....	30
8.5 Setting Dialog-Admin .....	31
8.6 Log View .....	37
<b>9. Print Mode.....</b>	<b>38</b>
<b>10. Self Inspection and Maintenance.....</b>	<b>39</b>
10.1 Before Calling a Service Person.....	39
10.2 Fuse Replacement.....	41
10.3 Service Information .....	42
<b>11. Specifications .....</b>	<b>43</b>
<b>12. ACCESSORY.....</b>	<b>44</b>
<b>13. Packing .....</b>	<b>45</b>
13.1 Packing Foam Design.....	45
13.2 Packaging step .....	46
<b>14. EMC (ELECTROMAGNETIC COMPATIBILITY).....</b>	<b>47</b>
<b>15. Disposal of waste products.....</b>	<b>50</b>

# 1. IMPORTANT NOTICE

## 1.1 Intended Use

The Auto Refractor/Keratometer **URK-800A** is used to determine the initial objective refractive values for a patient's eye in the workflow of refraction to determine the optical prescriptions for myopia, hyperopia and astigmatism.

## 1.2 Classifications

### **[Classification under the provision of 93/42/EEC(MDD)] Class II a**

The URK-800A is classified as Class II a device

### **[Form of protection against electric shock] Class I**

The URK-800A is classified as Class I.

This product is always protected when you connect the power supply must be connected to ground included. Class I is a product in which the protection against electric shock does not rely on basic insulation only, but which includes an additional safety precaution in such a way that means are provided for the connection of the product to the protective (ground) conductor in the fixed wiring of the installation in such a way that accessible metal parts cannot become live in the event of a failure in the basic insulation. Use a power outlet which is equipped with a grounding terminal.

### **[Degree of protection against electric shock] Type B Applied Part**

The URK-800A is classified as a device with a Type B Applied Part

### **[Degree of protection against ingress of liquids] IPX0**

The URK-800A is classified as IPX0

### **[Degree of protection against flammability]**

The URK-800A is classified as a device not suitable to be used in a potentially flammable environment. Do not use near flammable materials

### **[Method(s) of sterilization or disinfection recommended by the manufacturer]**

The forehead rest and chinrest should be wiped using a cloth dampened with soapy water as necessary

### **[Mode of operation]**

Classification of URK-800A : continuous operation

### 1.3 Caution

This product may malfunction due to electromagnetic waves caused by portable personal telephones, transceivers, radio-controlled toys, etc.

Be sure to avoid having objects such as, which affect this product, brought near the product. It should be used under the supervision of medical staff of hospital

The information in this publication has been carefully checked and is believed to be entirely accurate at the time of publication. URK-800A assumes no responsibility, however, for possible errors or omissions, or for any consequences resulting from the No use of the information contained herein.

URK-800A reserves the right to make changes in its products or product specifications at any time and without prior notice, and is not required to update this documentation to reflect such changes.

	<p>“ Do not modify this equipment without authorization of the manufacturer.”                  “ If this equipment is modified, appropriate inspection and testing must be conducted to ensure continued safe use of equipment”</p>
---	---



**UNICOS Co., Ltd**  
**ADD: 282-30, MUNJI-RO, YUSEONG-GU,**  
**DAEJEON, KOREA**

**Tel : +82-42-825-8045**  
**Fax : +82-42-581-0053**

All rights reserved.

Under copyright laws, this manual may not be copied, in whole or in part, without the prior written consent of URK-800A

## 2. SAFETY

### 2.1 SAFETY INFORMATION

Accessory equipment connected to the analog and digital interfaces must be certificated according to the respective IEC/EN standards (e.g. IEC/EN 60950 for data processing equipment and IEC/EN 60601-1 for medical equipment).

Furthermore all configurations shall comply with the system standard EN 60601-1-2:2007. Everybody who connects additional equipment to the signal input part or signal output part configures a medical system, and is therefore responsible that the system complies with the requirements of the system standard EN 60601-1-1:2001.

If in doubt, consult the technical service department or your local representative.

#### For EU Countries

- The following mark, the name & address of the EU Representative shows compliance of the instrument with Directive Council Directive 93/42/EEC of 14 June 1993 as amended by Directive 2007/47/EC concerning medical devices.

#### ISO 15004

- This report provides information about the hazard to the examinee's eyed in compliance with ISO 15004-1:2006, ISO 15004-2:2007 Ophthalmic instruments – Fundamental requirements and test methods Part2– Light hazard protection. This condition is satisfied even when the instrument is operating at maximum light intensity and maximum aperture! (Maximum intensity is the highest brightness the instrument is capable of delivering, including the highest brightness achievable if overvoltage is provided) detailed radiation information at normal usage of this instrument is like bellows.





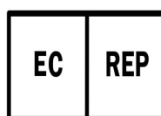













Radiation output: below 117.1  $\mu\text{W}/\text{cm}^2$  Limit by ISO15004: 100  $\text{mW}/\text{cm}^2$

Number	Radiation output [ $\mu\text{W}/\text{cm}^2$ ]
1	107.0
2	117.1
3	115.5
4	115.7
5	103.6
6	103.7
7	108.8
8	109.0
9	105.6
10	105.8
average	109.1





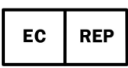

Ellegi Medical Optics s.r.l.  
Via Pisciarelli 79- 80078,  
Pozzuoli(NAPLES) ITALY

## 2.2 Symbol Information

Symbol	Descriptions
	TYPE B EQUIPMENT
	Protective earth (ground)
	Alternating current
	Off (power: disconnect to the mains)
	On (power: connection to the mains)
	Do not throw away the waste to inappropriate place
	Crushing hazard sign
	Hand hazard sign
	Instruction for user manual
	Operating instructions
	CAUTION
	Keep dry symbol
	DO NOT Hand Hooks symbol
	Fragile symbol
	This way up symbol
	Handle with care symbol
	Do not build up more than 2 boxes
	Manufacture
	Europe Representative

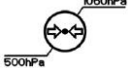

	Manufacture Date
	Only one unit in the box
	Temperature between - 40°C ~ 70°C
	Humidity between 10%RH ~ 95%RH
	Air pressure between 500hPa ~ 1060hPa

### 2.3 Shape Of Plug

Country	Voltage/frequency	Shape of plug
Mexico	110V/50Hz	Type C&E
Argentina	220V/60Hz	Type A
Peru	220V/60Hz	Type A
Venezuela	110V/50Hz	Type C&E
Bolivia & Paraguay	220V/60Hz	Type A(Most common) / Type H(Infrequently)
Chile	220V/60Hz	Type A
Colombia	110V/50Hz	Type C
Brazil	220V/60Hz 127V/60Hz	Type A Type C
Ecuador	110V/50Hz	Type C&E
USA	120V/60Hz	Type A(Hospital Grade)
Canada	120V/60Hz	Type A(Hospital Grade)

## 2.4 General Safety Information

If you see any warnings or cautions printed on the warning labels, follow the safety instructions in this manual. Ignoring such cautions or warnings while handling the product may result in injury or accident. Be sure to read and fully understand the manual before using this product.

Keep this manual in easy-to-access place.

### Safety Symbols and sign



This indicates hazardous situations which may result in crush your hand.



This indicates hazardous situations which may result insert your hand.

#### **NOTE**

This is used to emphasize essential information. Be sure to read this information to avoid incorrect operation.



## 2.5 Cautions in Installation , Storage and Transportation

- Exposure to the direct sunlight or too bright indoor lights may influence on the result of accurate measurement. Use the appropriate Optometry room.
- Keep the objective glass of the examinee side clean. If it was stained, it may cause on ERROR or inaccurate measurements.
- In case you leave URK-800A without using for certain period, disconnect the power supply and protect the unit with dust cover.
- In case moving this URK-800A, fix the stage by using clamping bolt and stage holding knob, always keep power off, and then lift the bottom of the unit with both hands.
- In case moving this URK-800A, do not hold forehead.
- In case moving and connect other device this URK-800A, keep in touch with qualified technician or service agent and place the equipment plain.
- Get worked, store and move under the following environment conditions for proper operation.
- Operation environment :
  - Temperature : +10℃ ~ +40℃
  - Humidity : 30% ~ 80% RH
  - Atmospheric pressure range : 700 hPa ~ 1060 hPa
- Storage and Transportation environment :
  - Temperature : +10℃ ~ +55℃
  - Humidity : 10% ~ 90% RH
  - Atmospheric pressure range : 500 hPa ~ 1060 hPa

## 2.6 Patient environment

The patient environment represents a space where there is a possibility of direct contact between the patient or the operator and third person.

When another type of device is used in the patient environment, use a device that complies with IEC 60601-1. If the devices that do not comply with IEC 60601-1 are used, it is necessary to use an isolating transformer to power the device or to connect the devices to additional protective grounding.

- ① Patient environment (represented by dotted line, extending exactly 1.5 meters)
- ② URK-800A equipment
- ③④ Peripheral equipment(EN XXXXX and IEC XXXXX)
- ⑤ Power cord(⑤included protective earth)

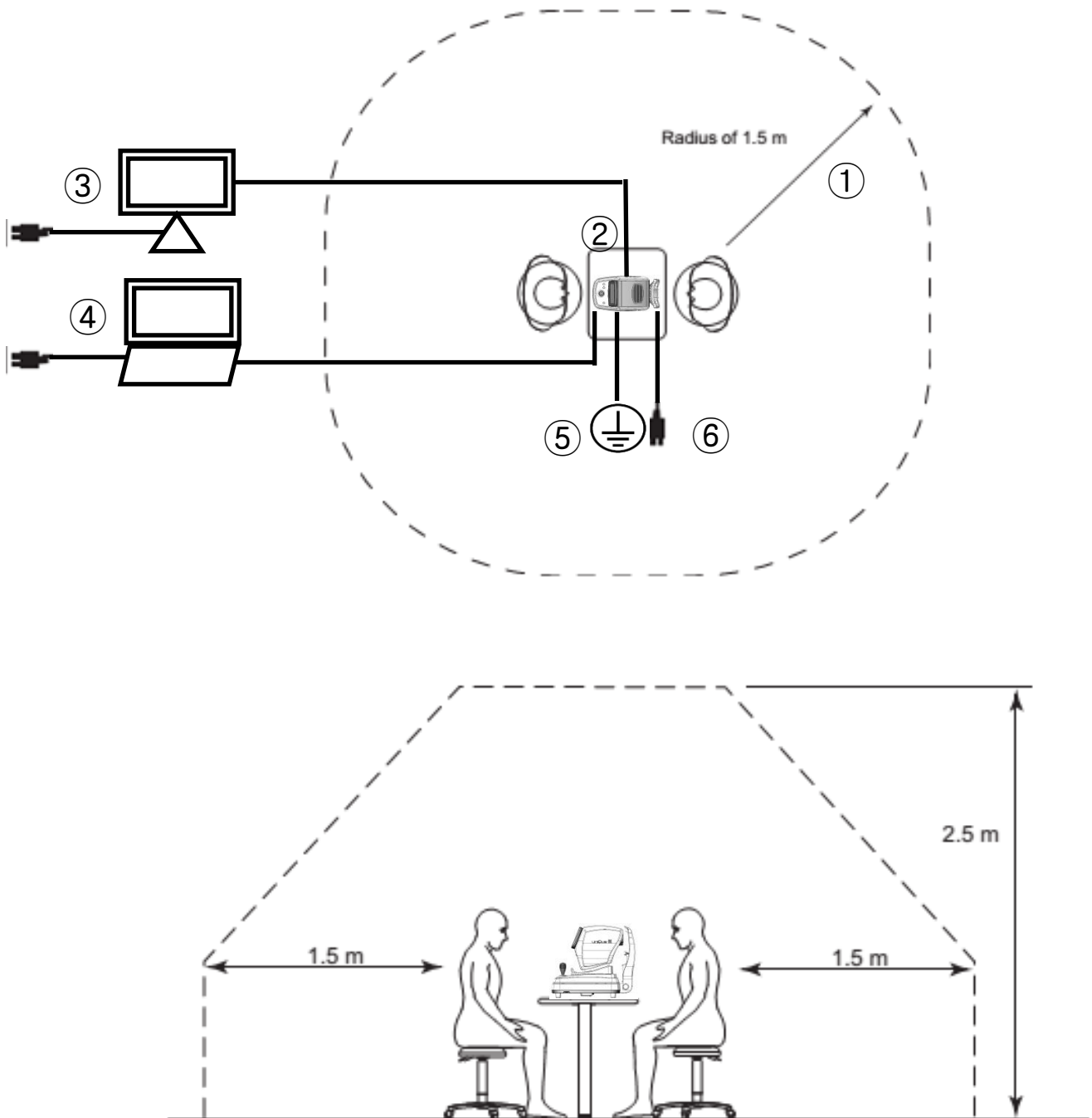

## 2.7 Labels

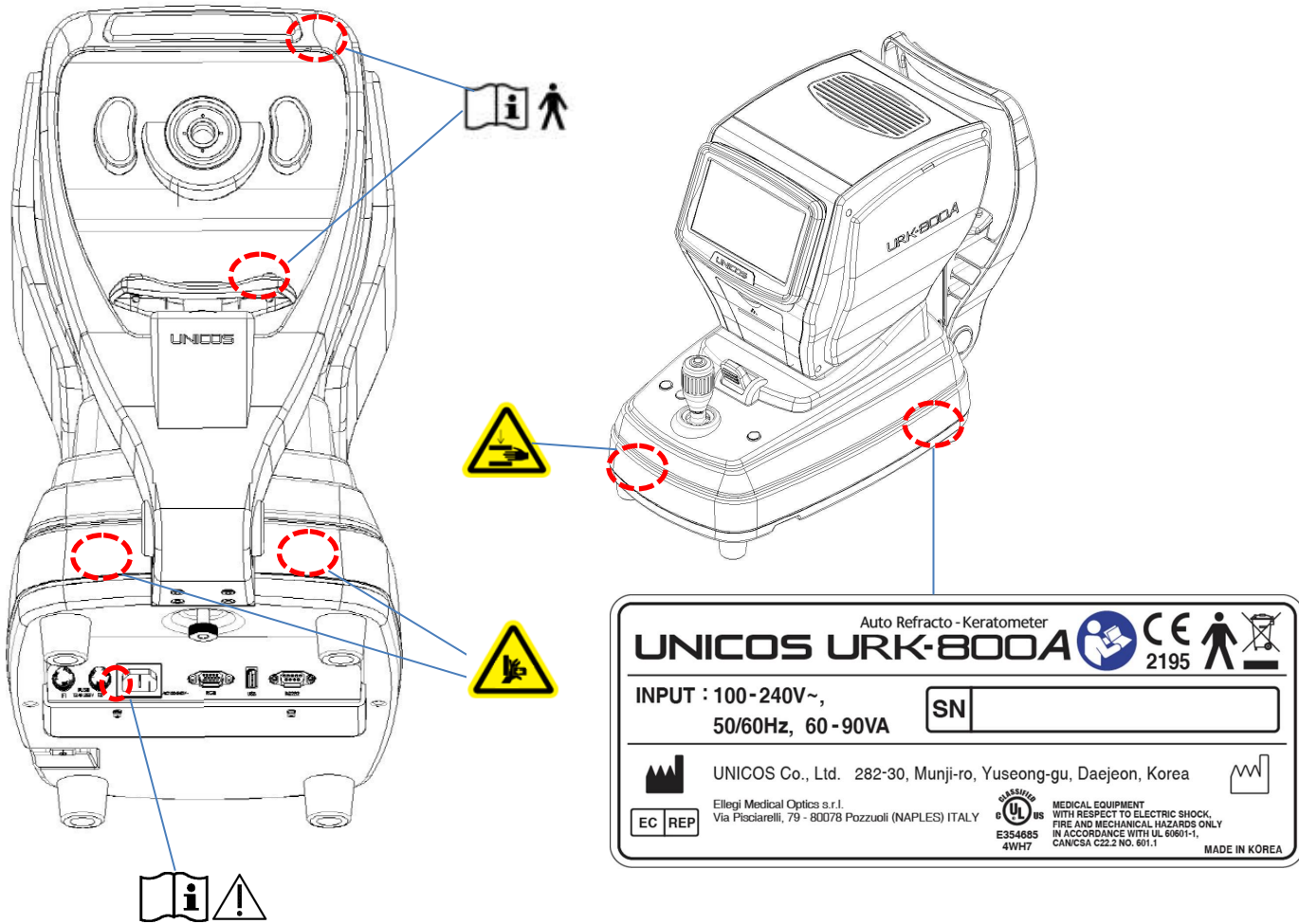

The following labels and indications are affixed to draw the operator's attention



### 3. Features

- **Various Measurements Supported**  
Not only the usual refractometry and keratometry, but also corneal diameter and base curve of contact lens can be measured with this one instrument. Thus, measurements of eye and prescriptions for glasses and contact lenses can be made more efficiently.
- **Wide Dioptric Measurement Range**  
Because the URK-800A covers a wide measurement range, from -25D to +22D, even an examinee with strong myopia can be measured.
- **More accurate Measurement**  
The fogging method of the eye fixation target makes examinee's eye comfortable and enables to get more accurate measurement data
- **Simple and convenient user's environment**  
Deliver more convenient user environment with wide viewed 7.0" TFT COLOR LCD screen and with simple and intimate design.
- **Developed illumination**  
This function is able to observe eye condition of the cataract or contact lens surface. It is able to save 2 images of each eye and continuous observation.
- **Easy Connection with other Equipment**  
This instrument is designed to connect other Equipment such as LCD monitor.

## 4. Notes for Using the Instrument

	<ol style="list-style-type: none"> <li>1. To avoid the risk of electric shock, this equipment as power protective earth connection must be connected</li> <li>2. Ensure that the examinee has not placed his/her hand or fingers under the chin rest. Otherwise, hand or fingers may be hurt.</li> <li>3. Do not hit or drop the instrument. The impact may cause damage to the function of this instrument. Please handle with care.</li> <li>4. Only operate the instrument with the power supply indicated on the rating plate. Otherwise, it may result in fire or electric shock.</li> <li>5. Never disassemble or modify. This can cause fire or electric shock.</li> <li>6. In case there is smoke, strange odor or noise during operation, disconnect the power supply and consult the distributor.</li> <li>7. For replacement parts (battery, fuse, or other parts), please contact the distributor from whom you purchased the product.</li> <li>8. The external connection device is used UL certificate device and the specified power code, paper and fuse are used.</li> </ol>
	<ol style="list-style-type: none"> <li>1. A sudden heating of the room in cold areas will cause condensation on the protective glass in the monitor screen and on optical parts inside the instrument. In this case, just wait until condensation disappears before performing measurement.</li> <li>2. Keep the objective glass of the examinee side clean. If it was stained, it may cause on ERROR or inaccurate measurements.</li> <li>3. If you leave URK-800A without using for certain period, disconnect the power supply and protect the unit with dust cover.</li> <li>4. When moving this URK-800A, fix the stage by using clamping bolt and stage holding knob, always keep power off, and then lift the bottom of the unit with both hands.</li> <li>5. When moving this URK-800A, do not hold forehead.</li> <li>6. When moving and connect other device this URK-800A, keep in touch with qualified technician or service agent and place the equipment plain.</li> <li>7. The patient should raise your hands in your lap when measuring</li> <li>8. When S/W version up, check the label on the main board.</li> <li>9. Optometry chamber is 55 ~ 100 [lux] illumination suitable.</li> </ol>



1. Don't use organic solvents such as alcohol, thinner, benzene, etc. to clean the surface of this instrument. It may damage the instrument.
2. Do not store alcohol, thinner and other flammable vapors and liquids in the vicinity of this equipment.
3. Do not turn off the instrument before finishing initialization. It may cause motor movement error.
4. Do not use outdoors. The instrument is designed to be used only indoors.
5. Do not use Humidity or dusty environment
6. Never disassemble or modify this instrument because it may result in fire or electric shock. Also, since this instrument incorporates high-voltage parts and other hazardous parts, touching them may cause death or serious injury.
7. Keep it away from other persons but qualified technician.
8. Be sure to turn OFF the power switch before connecting or disconnecting the cables. Also, do not handle them with wet hands. Otherwise, you may get an electric shock that may result in death or serious injury.
9. If you leave this instrument without using for certain period, disconnect the power supply
10. This equipment may be able to be operated improper by micro waves from cellular phones, walkie-talkie, remote controlled electric toys. Keep it away.

At the time of publishing the information in this book carefully identified and has been judged to be correct. However, there are mistakes and omissions that the UNICOS, the use of the information contained in this book is not responsible for the results that occurred.



## 5. Prerequisites for safety

### 5.1 Preparation before use

- Do not operate under direct sunlight or too strong lights
- Do not store alcohol, thinner and other flammable vapors and liquids in the vicinity of this equipment.
- Check the voltage.
- Check printing papers are ready
- Check chin rest is working properly
- Remove dusts, especially on the lens.

### 5.2 Preparation when you use

- Place this equipment plain
- Do not put others on this equipment
- Do not disassemble or modify on your own
- Stand 40 minutes and get it worked if it is stored at extended temperate place
- Keep it away from other persons but qualified technician.
- Be sure to unplug if do not use long.
- Do not turn off the instrument before finishing initialization.  
(Don't power off during loading)

### 5.3 Instruction and operation sequence

- Please connect the power plug.
- Press "ON"
- Put the chin on chin rest and make forehead stuck on to forehead rest
- Release stage by turning stage knob
- Press buttons what you want
- Try to get it worked as per the instructions of 7 and 9

### 5.4 Storage after use

- Cover it up and unplug if do not use long
- Clean with soft cloth, soaped and rinse, wipe dry
- Wipe lens and glass' dusts out with wind blower and with soft cloth.
- Fix by turning the fixation knob and keep it plain when you are about to move or lift up
- Do store at the following place
  - ① Not humid place
  - ② Not in the vicinity of water
  - ③ Not dusty and not in the vicinity of filthy place with salt or sulphur
  - ④ Plain place
  - ⑤ Not in the vicinity of vibration or shock
  - ⑥ Not in the vicinity of other flammables vapors or liquids
  - ⑦ Not in the vicinity of direct sunlight
- Store the accessories and cords for next operation.

## 6. Introduction

### 6.1 Front side of body

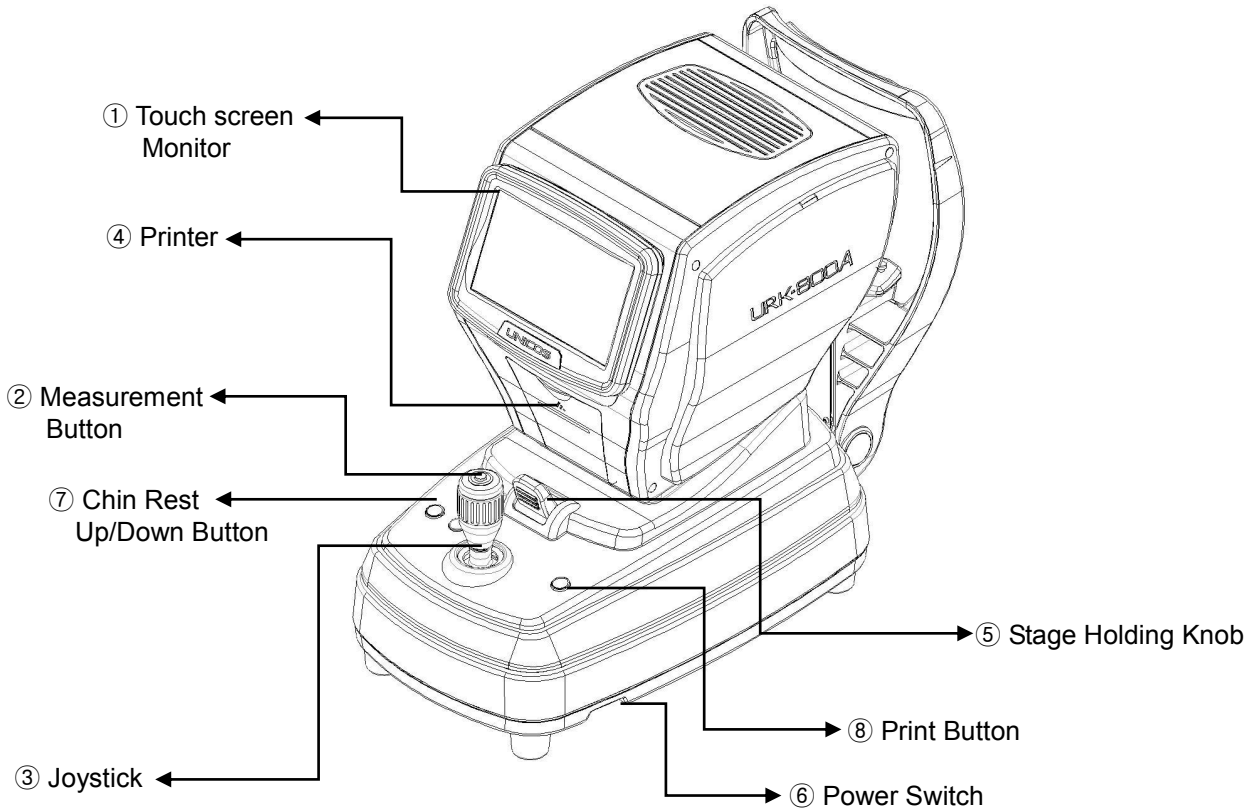

[ Drawing 1 ] Front Side

Name	Functions
① Touch screen Monitor	Monitor that displays Measurement
② Measurement Button	Press this button for measurement.
③ Joystick	Control lever for lining up and focusing
④ Printer	Print the measured result
⑤ Stage Holding Knob	Holds the movement of stage
⑥ Power Switch	Switch for turning power ON and OFF
⑦ Chin Rest Up/Down Button	For regulating height of chin rest
⑧ Print Button	Press to print measurements

[ Chart 1 ] Front side

## 6.2 Back side of body

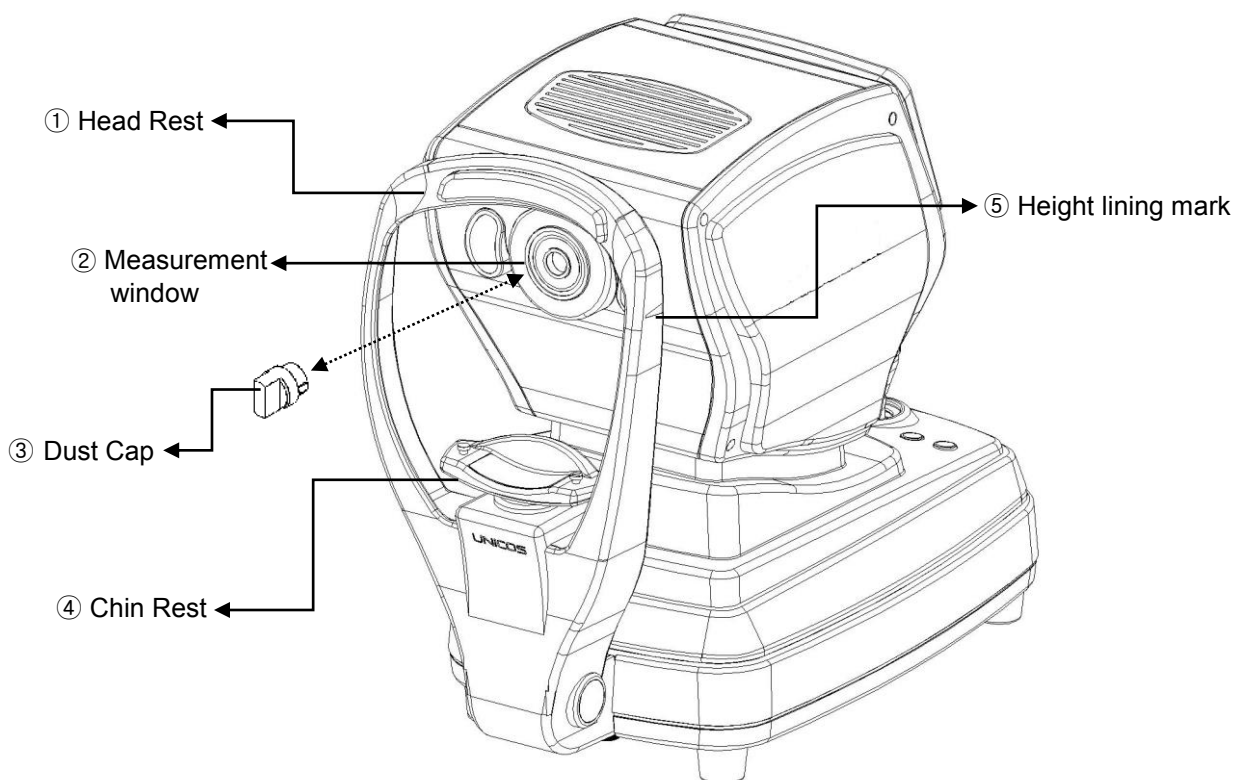

[Drawing 2 ] Back Side of Body

Name	Function
① Head Rest	Place the examinee's forehead against this rest.
② Measurement window	Window for the examinee to look at for measurement
③ Dust Cap	Anti-dust cap
④ Chin Rest	Place the examinee's chin on the rest.
⑤ Height lining mark	Lining up eye level of patient by regulating chin rest

[ Chart 2 ] Back side of body

6.3 Bottom side of body

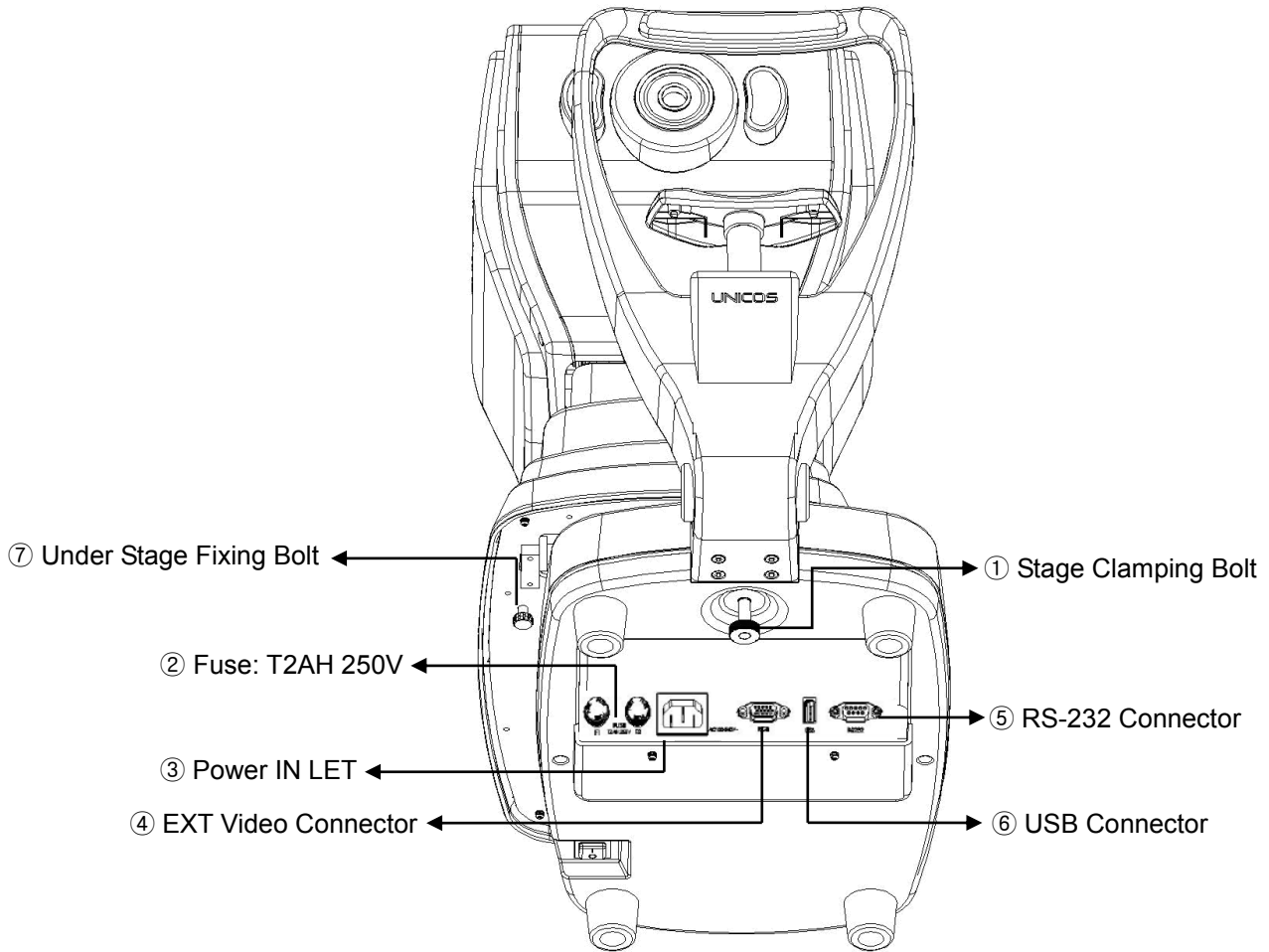

[ Drawing 3 ] Bottom Side of Body

Name	Function
① Stage Clamping Bolt	To clamp the stage during transportation.
② Fuse: T2AH 250V	Protects instrument from the excess electric power
③ Power IN LET	Connector for the power supply code
④ EXT Video Connector	Connect with external Video equipment
⑤ RS-232 Connector	Connect with PC
⑥ USB Connector	Connect with PC
⑦ Under Stage Fixing Bolt	Makes the system stage fixed

[ Chart 3 ] Bottom Side of Body

## 6.4 Plugging

- Put URK-800A on the table
- Connect power cord into power connector
- Check power switch OFF (O), plug into electrical outlet

## 6.5 Release stage fixing

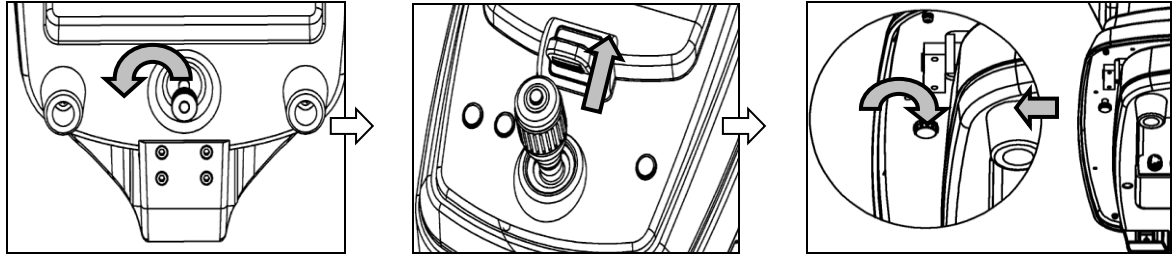

[ Drawing 5 ] Stage Clamping Bolt

- Rotate stage clamping bolt located in the bottom of body counterclockwise and release
- Lift stage holding knob straight up forward to 'UNLOCK'.
- Push stage to left and right and then loosen under stage fixing bolt.
- Check whether stage is moving freely.

## 6.6 Engage printing papers

- Check printing papers are inserted.
- If paper need to be replaced, change it with new paper (refer to '12.2 Switching printing papers').



Turn off the power after connecting or disconnecting the power cable. Do not operate the unit with wet hands. Otherwise, to cause death or serious injury can result in electric shock.

## 7. GUI(User Interface)

The user interface was applied to the touch-screen buttons of the URK-800A. So the user's convenience and speed of operation is improved. The frequently used buttons is located on the left and right of the screen frame. In the measurement mode is commonly used. The remaining modes except measurement modes each mode, please refer to the description page

### 7.1 Main Dialog

#### 1) Main Dialog1

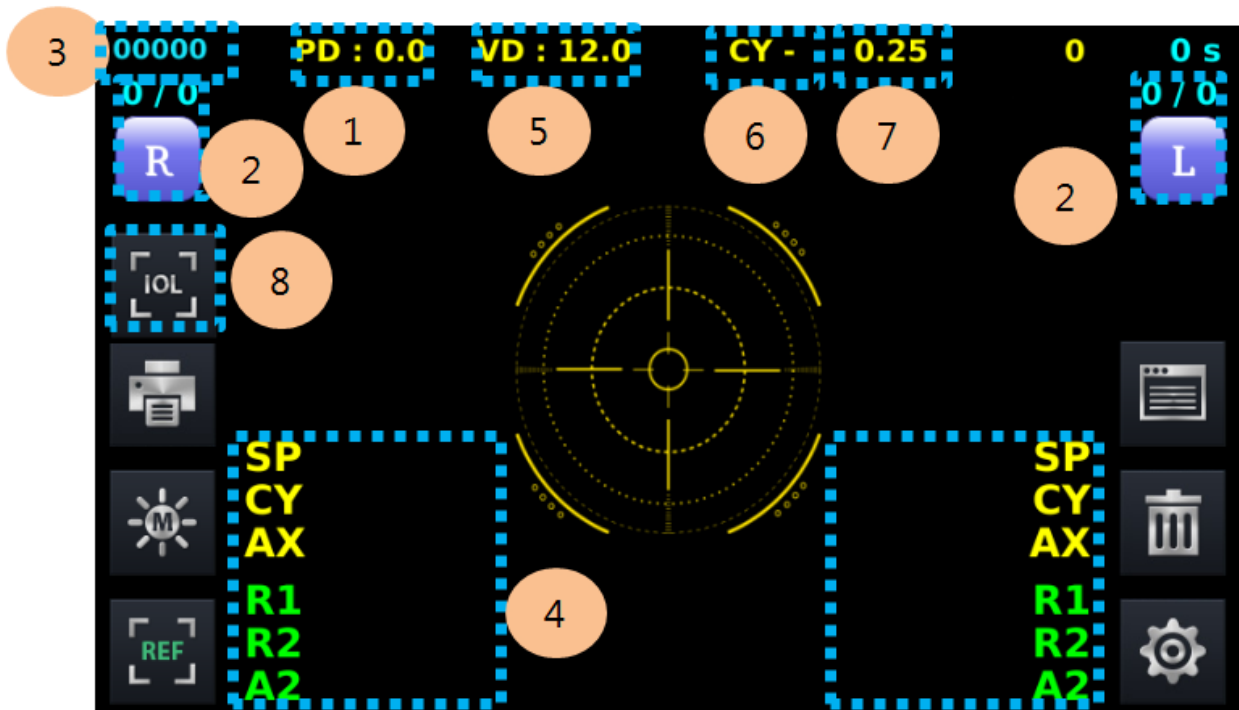

[ Drawing 4-1 ] Touch Screen 1

Name	Function
① PD	Display of PD(Pupil Distance) results.
② Left/Right	State of equipment direction (left / right) and Measurement count
③ Number	The number of patients to be recorded on the print out.
④ Measumemet Value(Right / Left)	Displays SPH, CYL., AXIS, R1, R2, A2 of measurement value(Right / Left)
⑤ VD (Vertex Distance)	Display of VD(Vertex Distance) results. When inactive, the touch screen entries and values VD. When you touch active in the VD is inactive. When you touch the value of the following values change: 0.0→10.0→12.0→13.5→15.0
⑥ CY	Select the negative & positive display method for Cylinder measurement(+ / - / ±)
⑦ Measurement step	Unit of measurement (Step : 0.12/0.25)
⑧ IOL	Intraocular lens mode

[ Chart 4 ] Operation Button

2)Main Dialog2

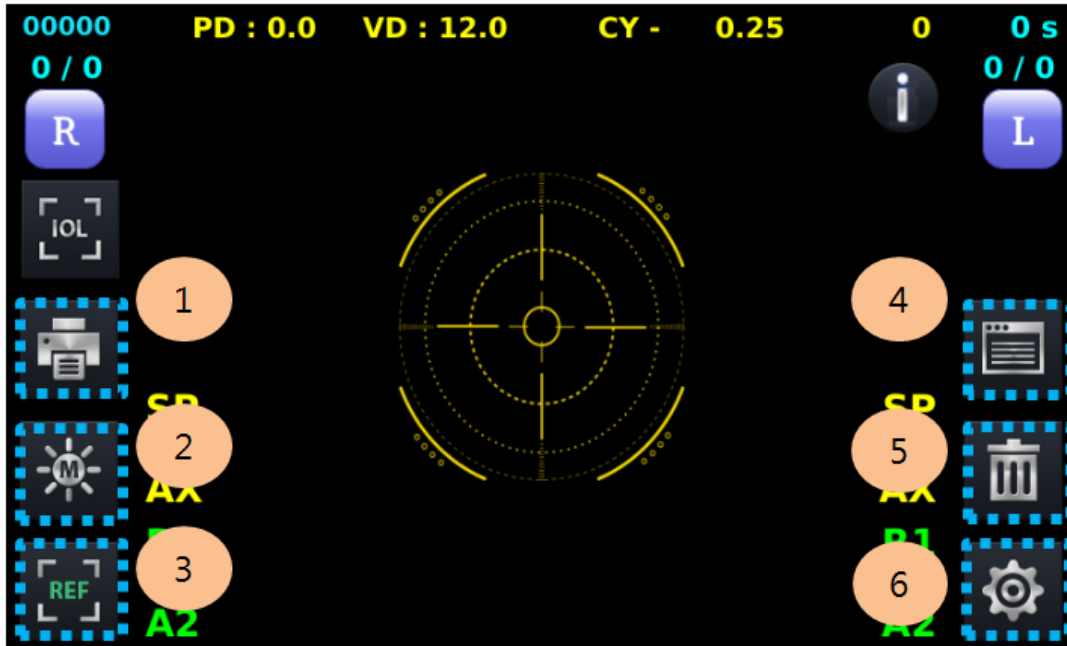

[ Drawing 4-2 ] Touch Screen 2

Name	Function
① Print out button	Prints measurement results
② Measurement Mode 1	-. A1: SIZE Auto measurement -. M: Manual (measured at current position)
③ Measurement Mode 2	Selects a measurement from REF, KER, R&K, CLBC and SIZE
④ Measurement Display button	Display of measument results.
⑤ Trash can button	Clears measurement data.
⑥ Settings button	Displays the Settings screen.

[ Chart 4 ] Operation Button

## 7.2 ILLUM Dialog

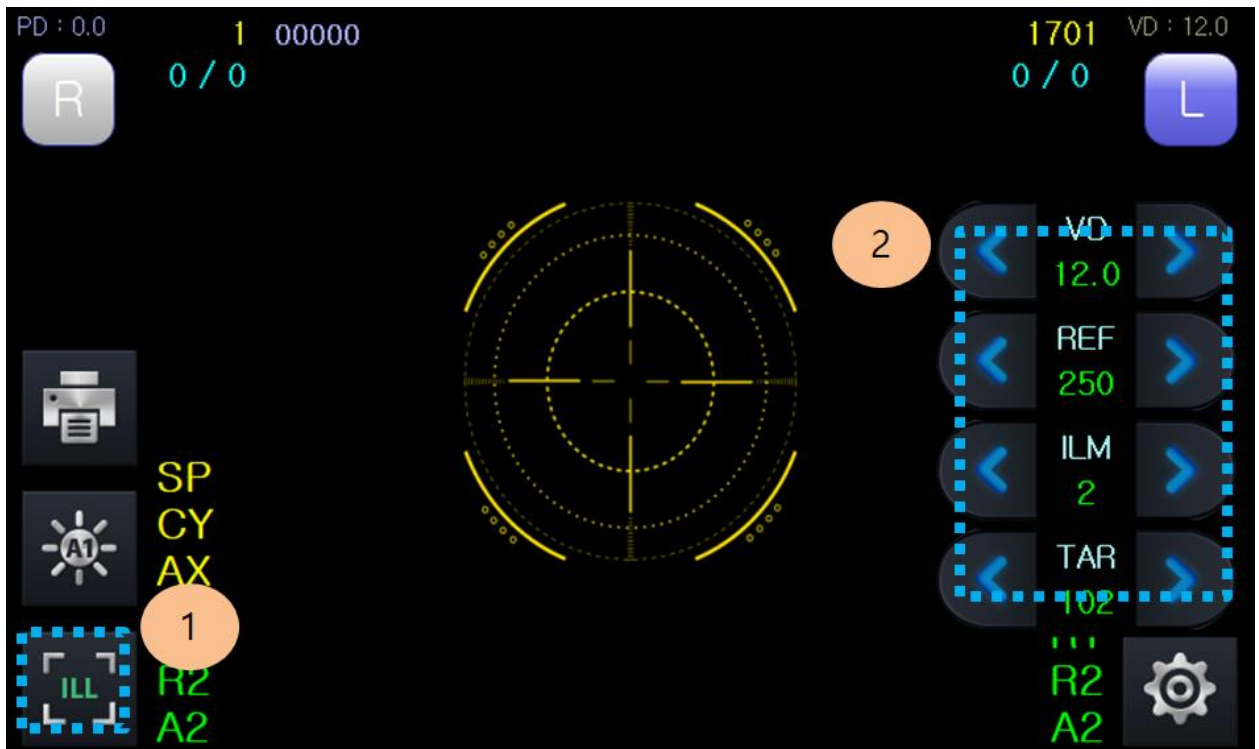

Name	Function
① ILLUM Display mode	Selects a measurement of ILLUM.
② Control Panel for ILL parameter	Control of VD, REF, ILM, TAR value.



### 7.3 KP Dialog

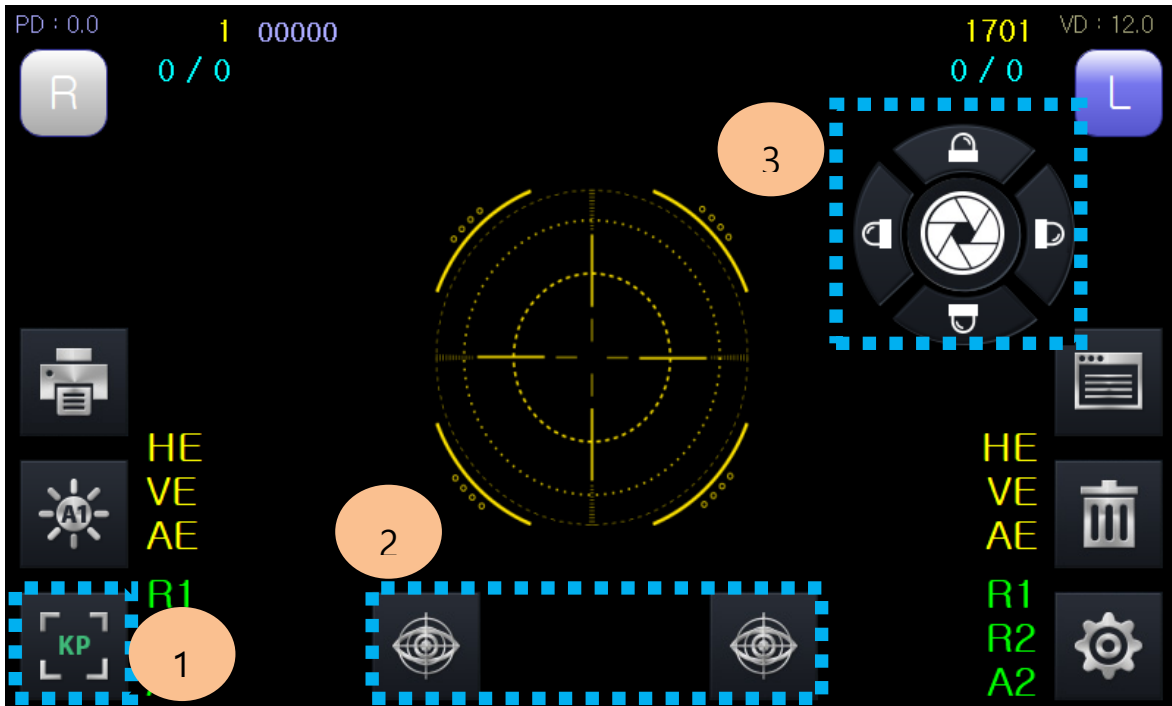

You start measurement in KP Mode, measure the Kerator value of the center and then measure the Kerato value of 4 position (up, down, left, right).

Name	Function
① KP Display mode	Display of KP mode.
② Measurement Direction Mode	Display of measurement direction
③ KP measurement result	Display of KP measurement result ( KP-Ker / KP-ECC, KP-Diop )

### 7.4 KP-Ker Dialog

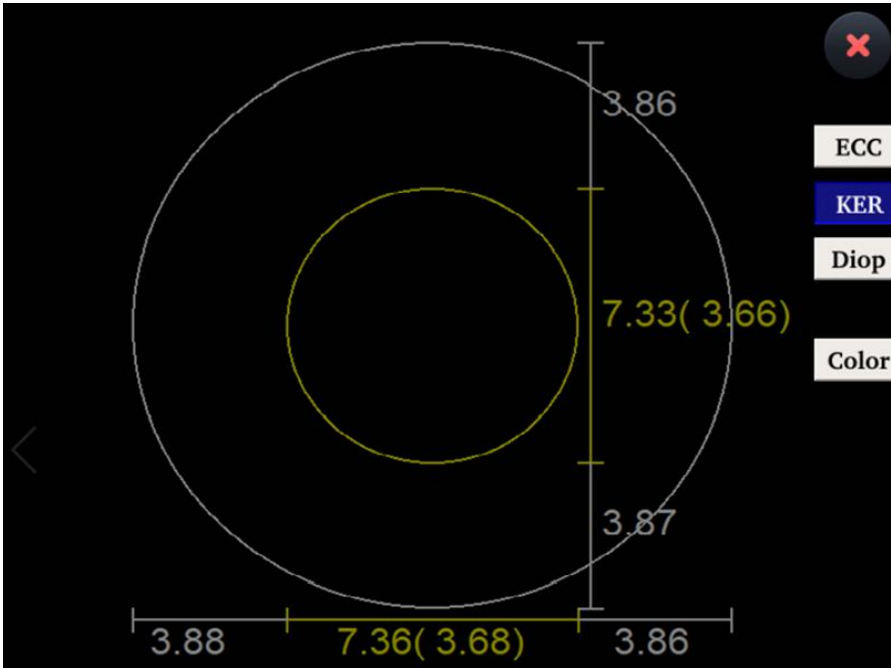

Display of KER measurement result.

### 7.5 KP-ECC Dialog



Display of ECC measurement result.

## 7.6 KP-Diop Dialog

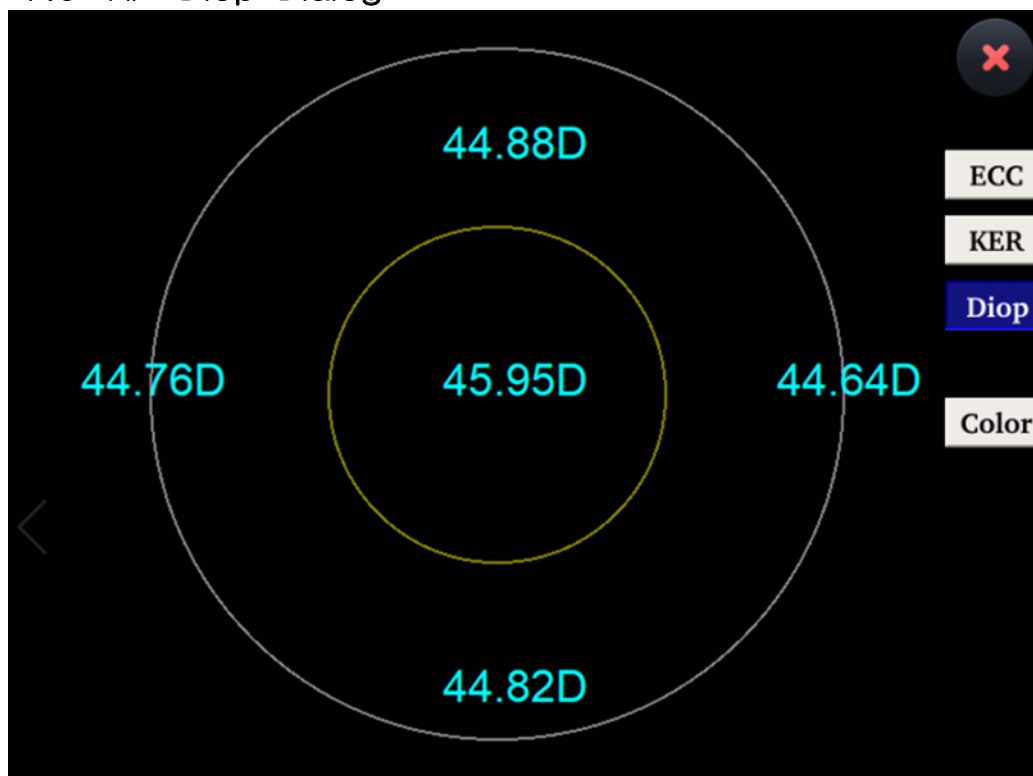

Display of Diop measement result.

## 7.7 Size Mode

### 1) Manual

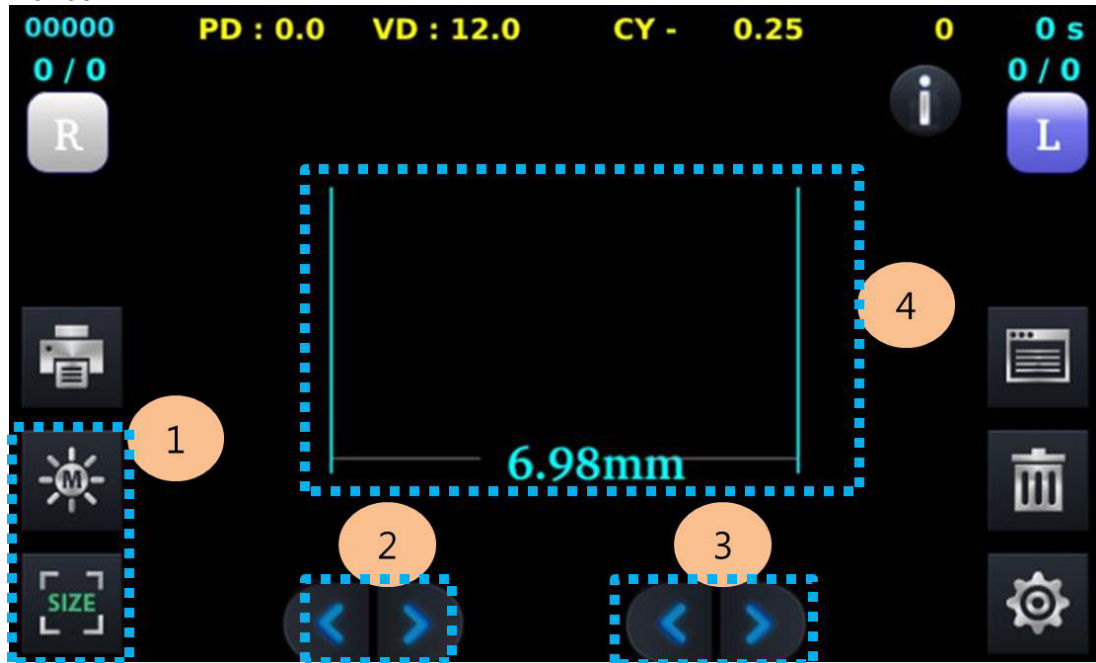

Name	Function
① Status	It is in the state of M(Manual mode)
② Left and right button	Use left and right buttons to move left line.
③ Left and right button	Use the left and right buttons to move the right line.
④ Measurement line	Left / Right line & pupil distance

## 7.8 Display Dialog

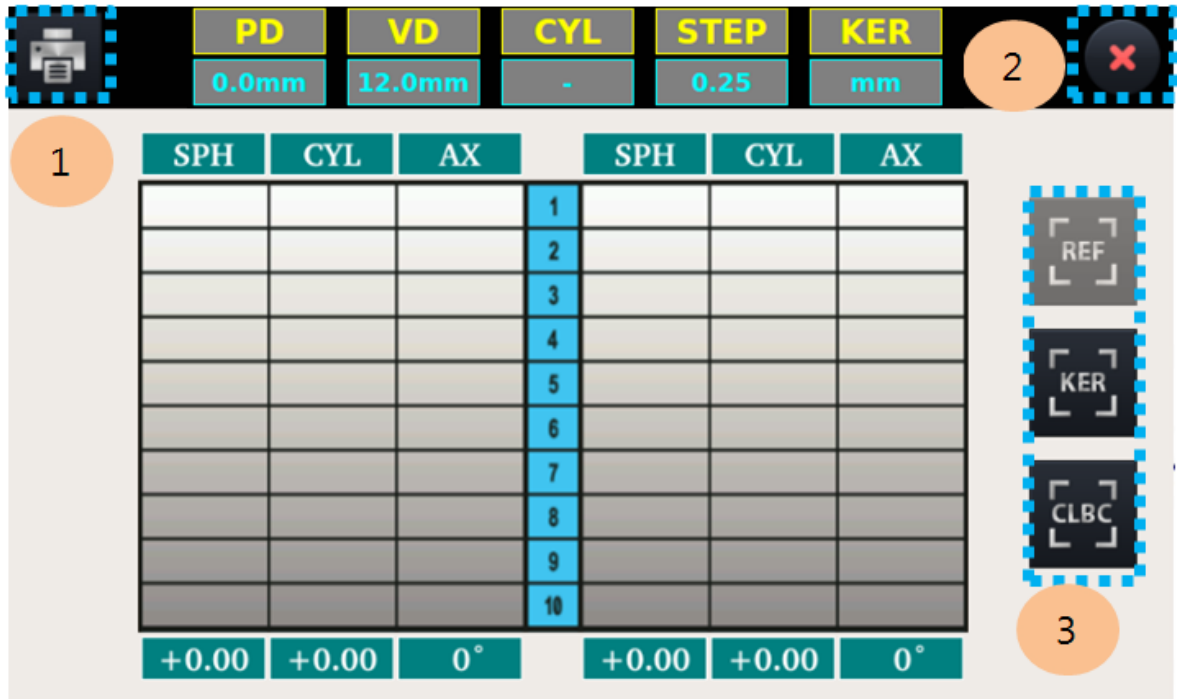

Name	Function
① Print button	Print the measured value.
② Exit button	Exit the current screen
③ REF/KER/CLBC	Display KER / REF / CLBC value.

8. Setting Dialog – Display

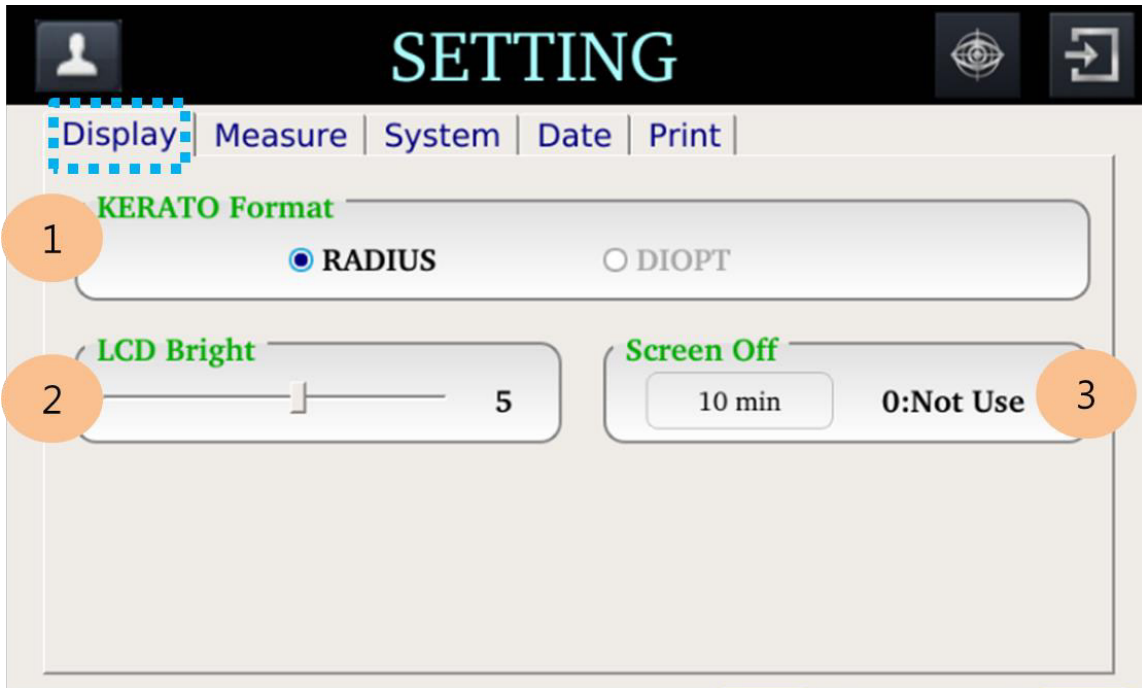

Name	Function
① KERATO Format	Unit of kerato measurement step (RADIUS/DIOPT)
② LCD Bright	Select the brightness of the screen
③ Screen off	Set the screensave mode start time

### 8.1 Setting Dialog–Measure

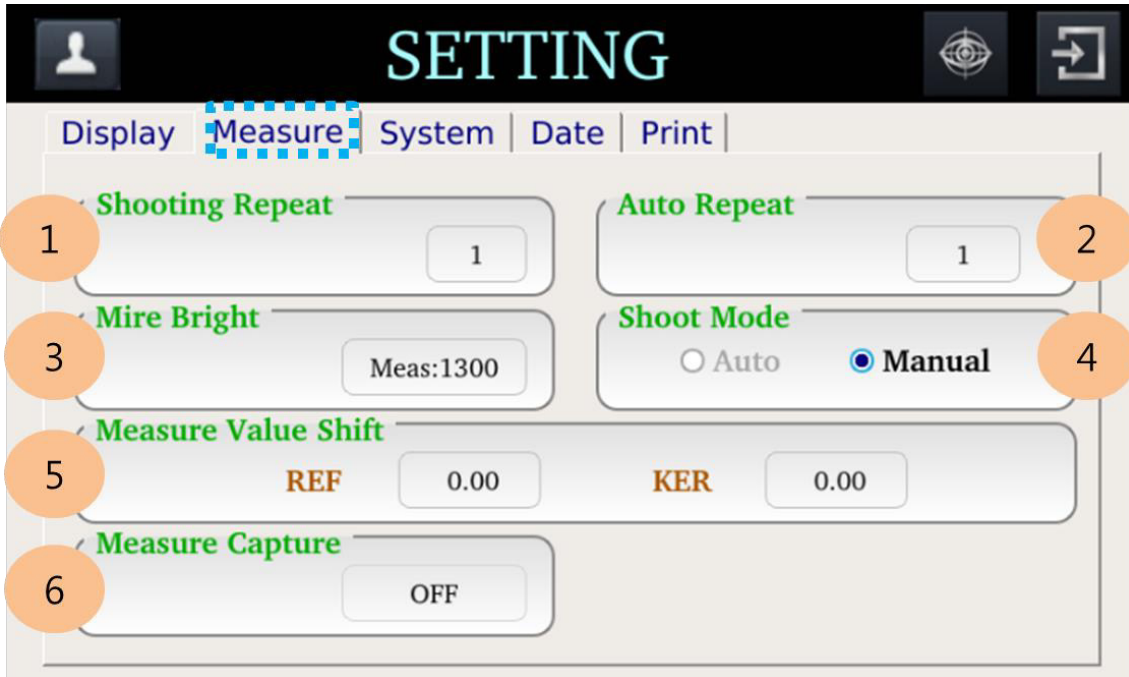

Name	Function
① Shooting Repeat	Unit showing the measured value
② Auto Repeat	Setting of Auto Repeat
③ Mire bright	Setting of mire bright
④ Shoot mode	Select the Auto measurement or Manual measurement type
⑤ Measure Value Shift	Setting calibration values for measurement at each mode(REF/KER)
⑥ Measure Capture	Activation of Measurement capture function

## 8.2 Setting Dialog–System

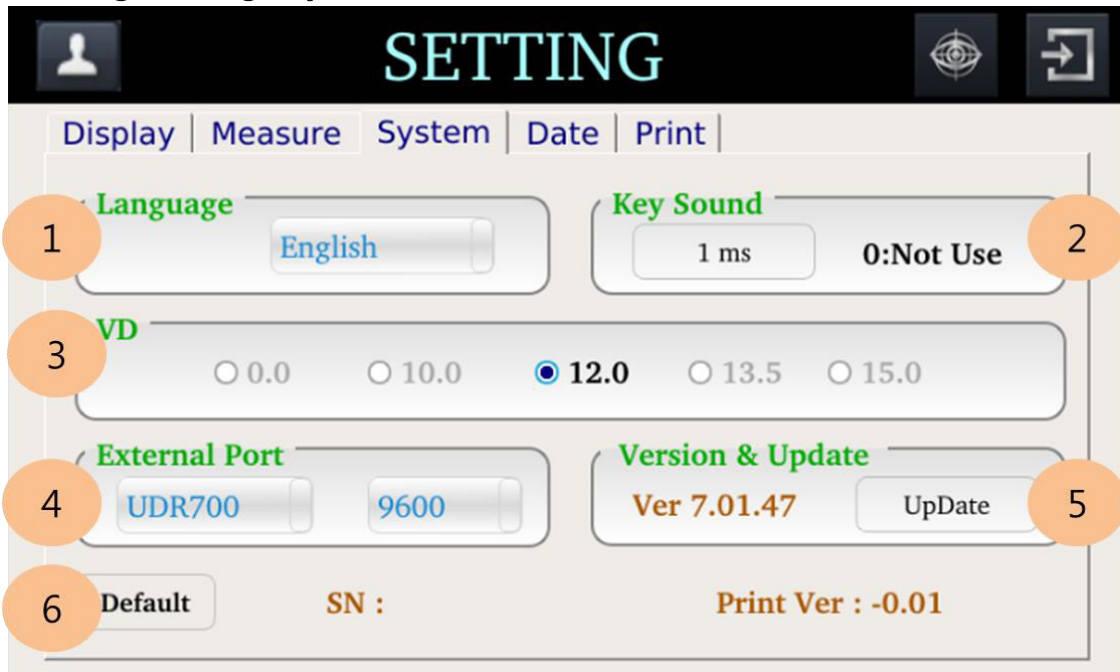

Name	Function
① Language	User Language Settings
② Key sound	Set the Key Operation Sound Volume
③ VD	Set default VD value
④ External Port	Compatible Equipment Settings
⑤ Version & Update	Show the current S/W version and update
⑥ Default	Reset of setting value



### 8.3 Setting Dialog-Date

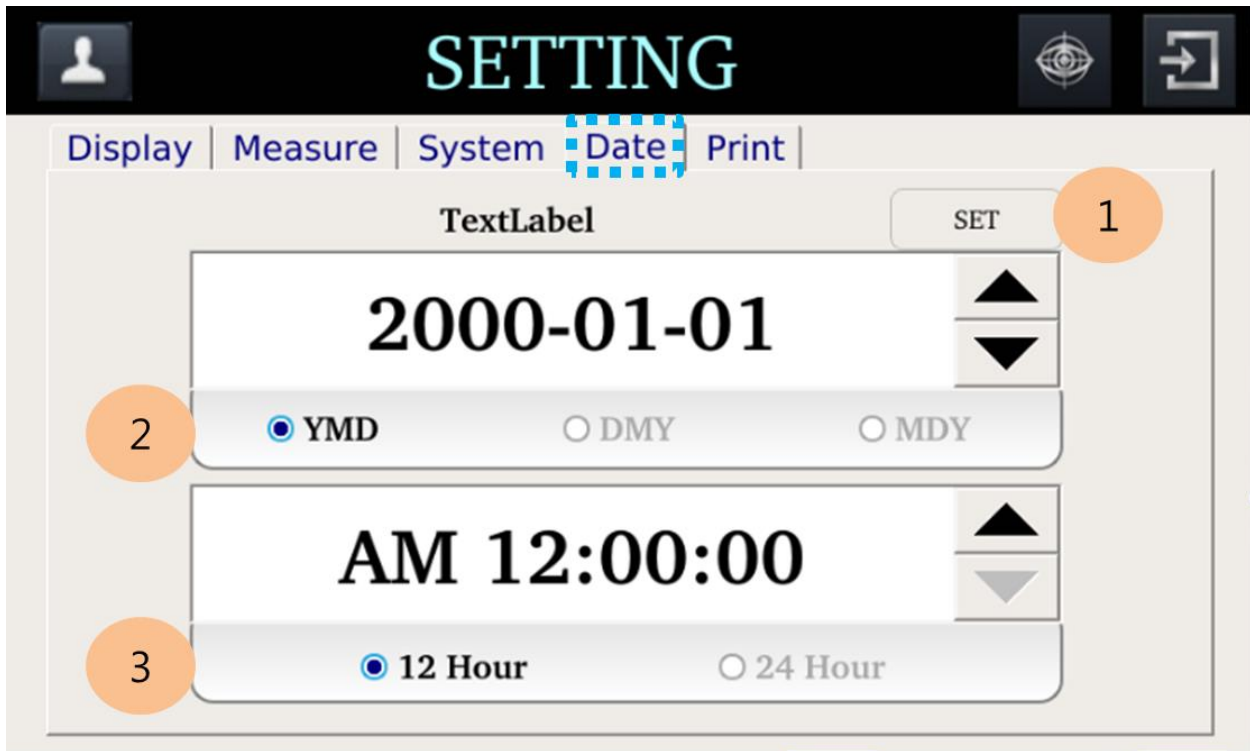

Name	Function
① SET	Save the setting value
② Date display method	YMD/DMY/MDY
③ Time display method	12 Hour/24 Hour

### 8.4 Setting Dialog-Print

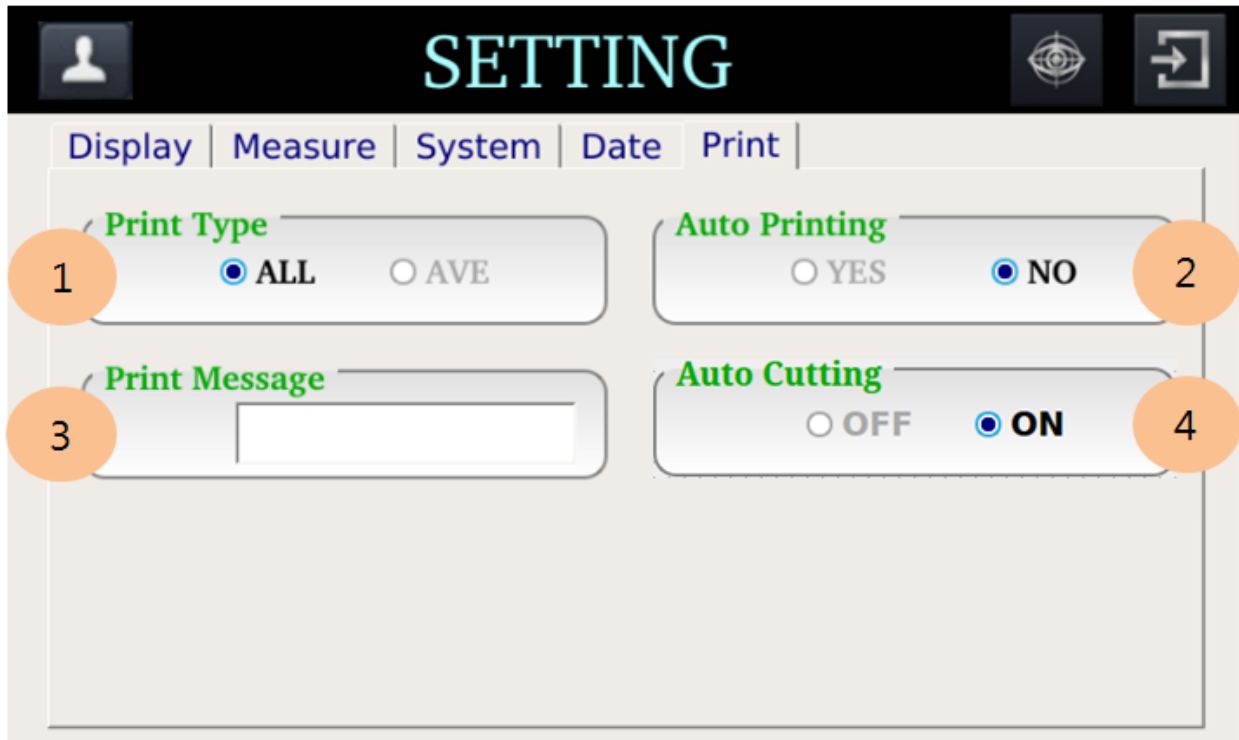

Name	Function
① Print Type	ALL/ AVR
② Auto Printing	Whether automatic printing is performed after measurement of both eyes
③ Print Message	Enter an output message when printing
④ Auto Cutting	Whether automatic cutting is performed after print

## 8.5 Setting Dialog-Admin

1) Activation of Admin mode

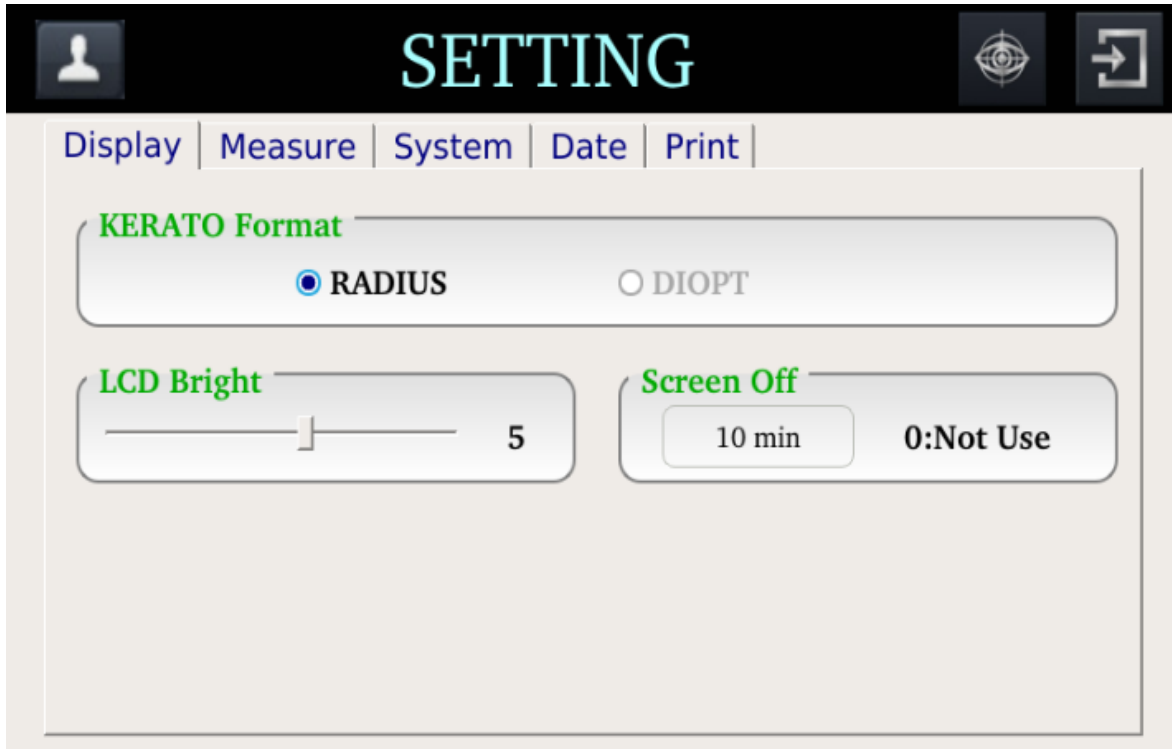

[ Touch the image  ]

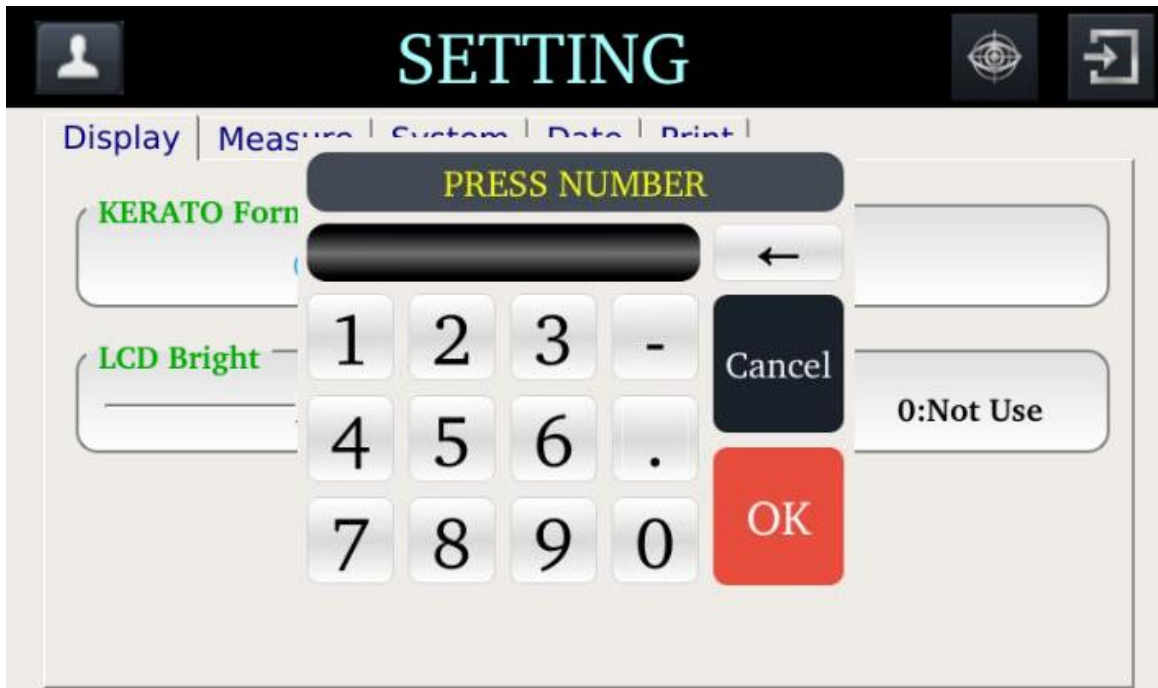

[Enter administrator number "1234"]

2) Admin mode

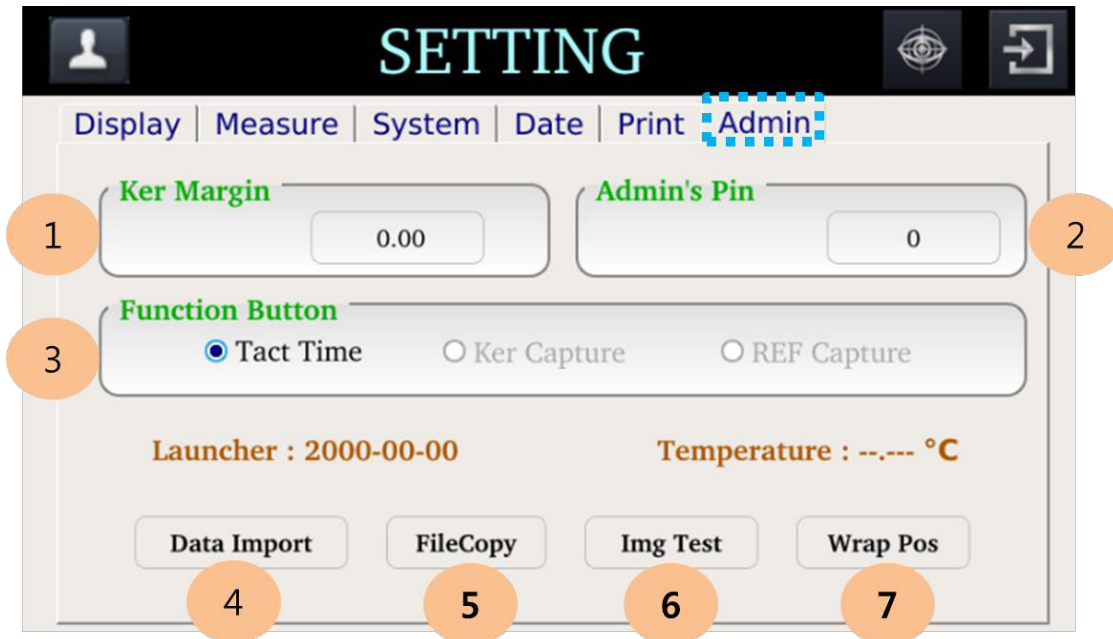

Name	Function
① Ker Margin	A value that compensates for differences in major axis / minor axis during Ker measurement. (Indicated by the average value if less than the range)
② Admin's Pin	Password to view admin page
③ Function Button	Activating the Measurement Time, Ker or Ref Image Capture buttons in Admin Mode
④ Data Import	Import the data (set value) of the equipment from USB.
⑤ File Copy	Copy user data to USB
⑥ Img Test	You can test the captured image
⑦ Wrap pos	Initialize the product to its before the packaging state.

3) Img Dialog



1. Image processing screen
2. Load the image and test the values required for image processing.

OPEN



1. Load the image to be processed.

**ORG**

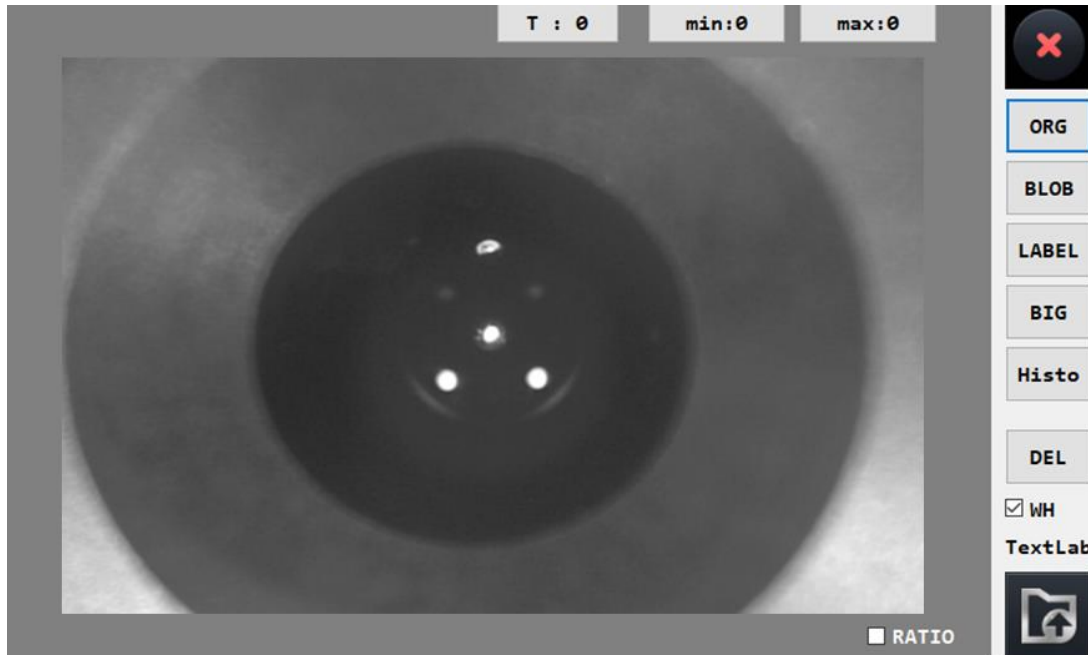

[Displays the original image]

**BLOB**



[T: 250 (extract blob by applying threshold value)]  
 \* You can modify the Threshold value (0 to 255).

### LABEL

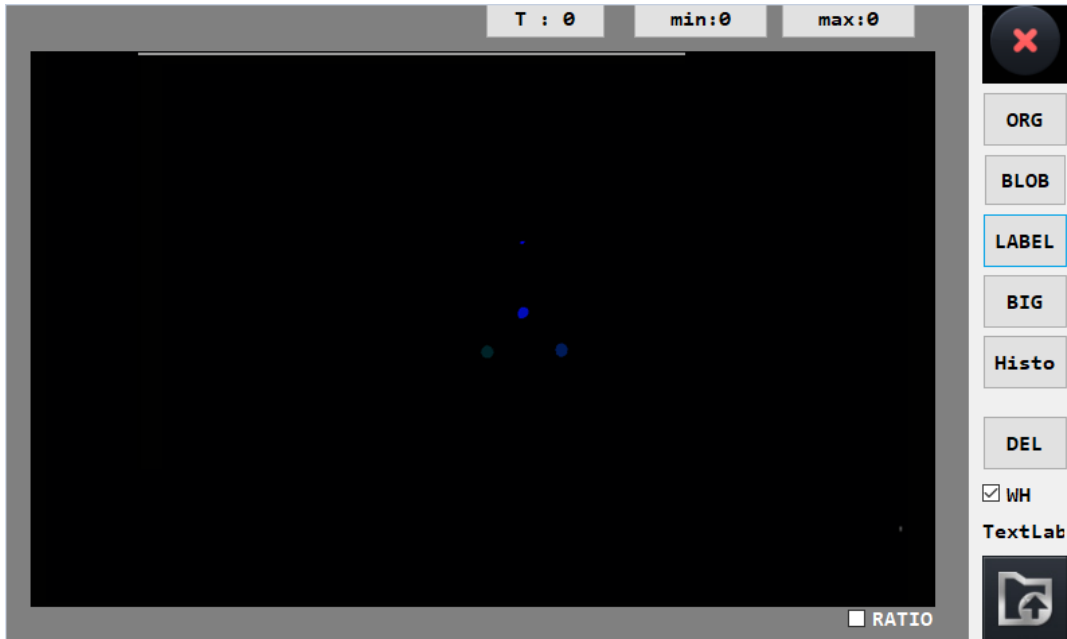

[Displays an independent blob (labeling)]

### BIG



[Click the BIG button to show only blobs matching the conditions (min: 100 ~ max: 300)]

Histogram1

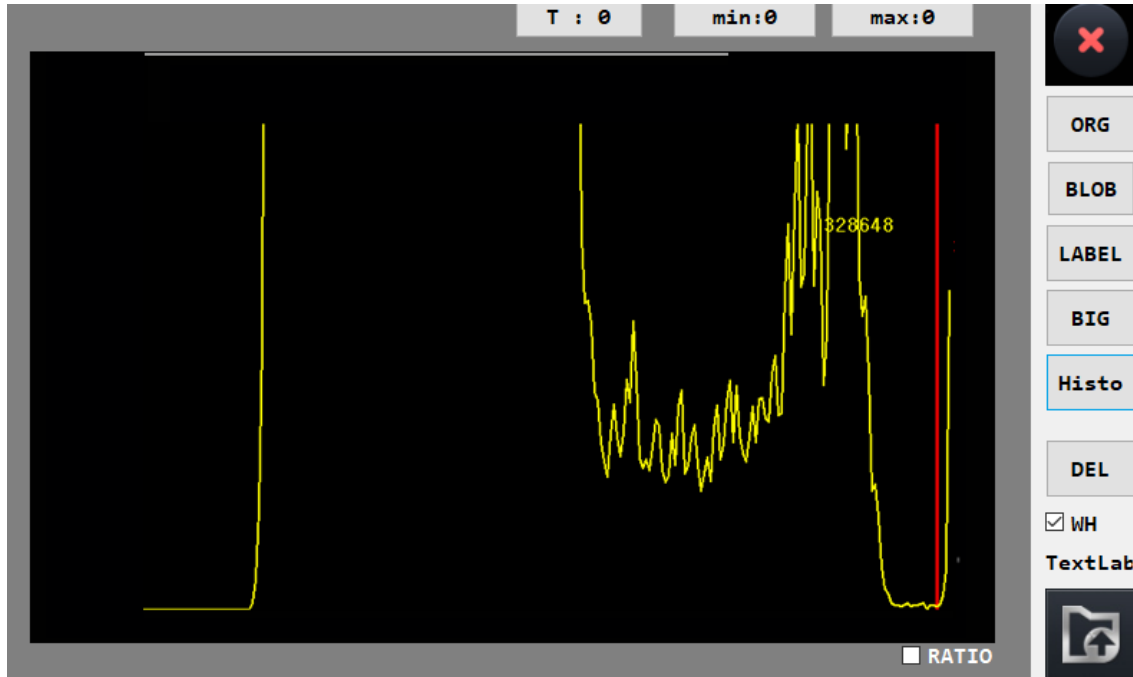

Click the Histo button to display the histogram of the current screen.  
The middle red line is the current threshold value



Turn off the power after connecting or disconnecting the power cable.  
Do not operate the unit with wet hands. Otherwise, to cause death  
or serious injury can result in electric shock.



## 8.6 Log View

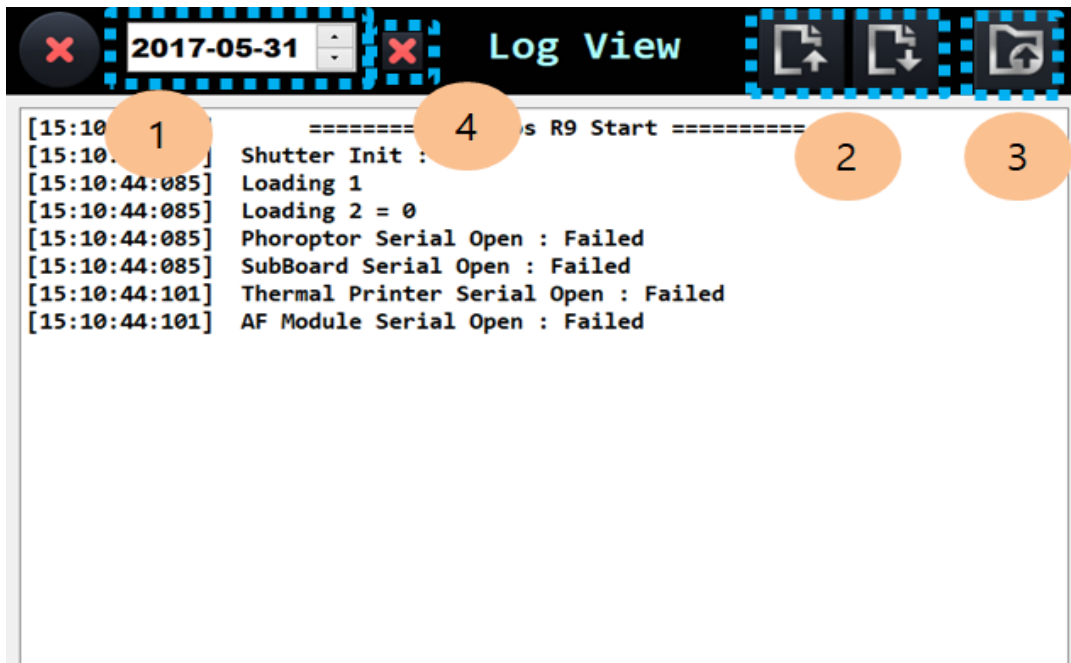
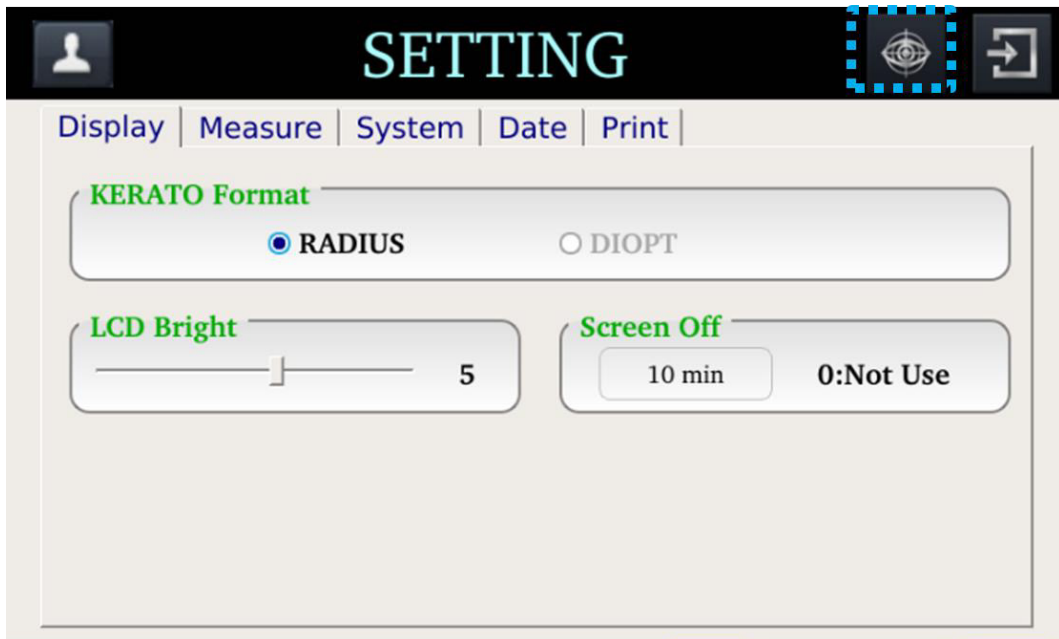

No.	Function
①	You can select the log date.
②	Page Up / Dn the log contents.
③	Load the log contents.
④	Delete the current log file

## 9. Print Mode

- Pressing the touch button(  ) to print the measured results will be printed when you print.
- Depending on the user setup mode is selected in different prints.

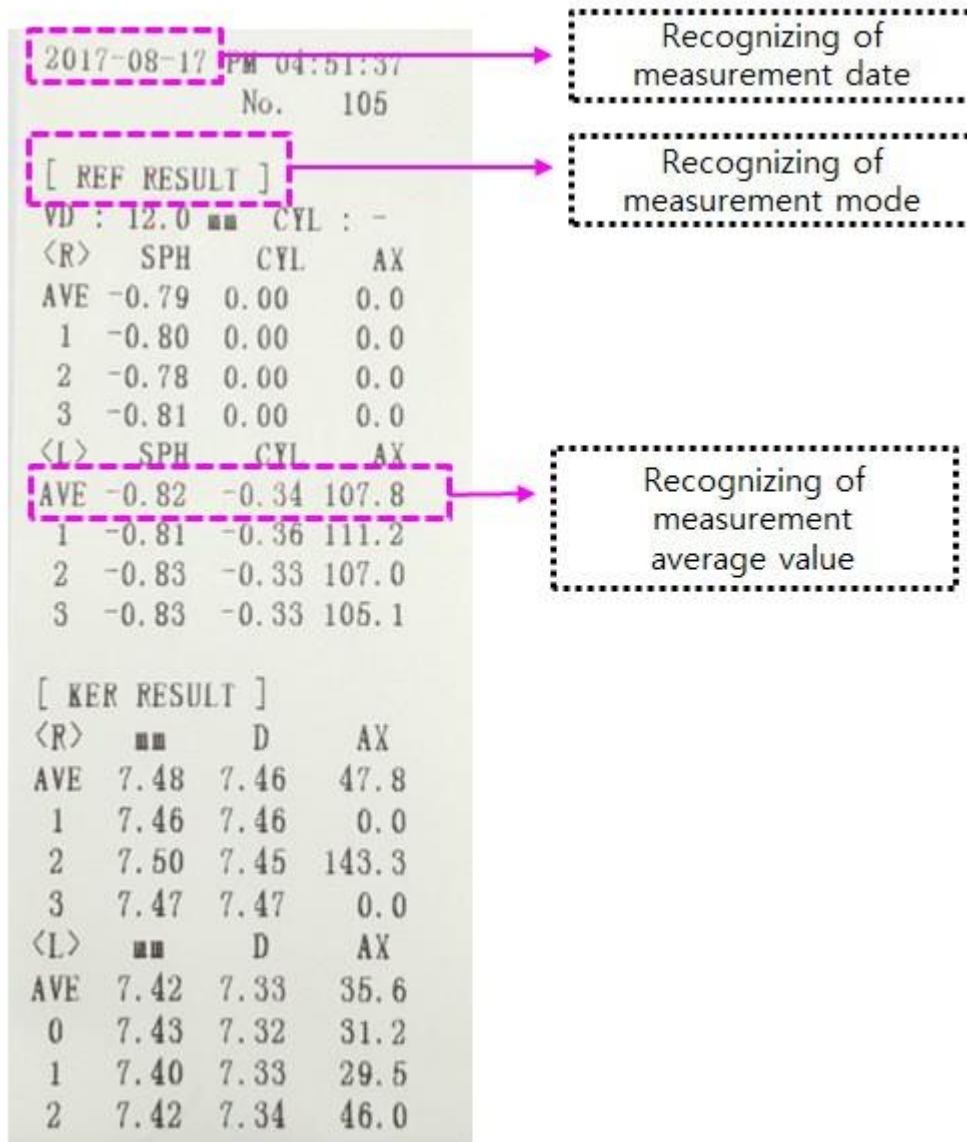

The print sample shows the following data:

2017-08-17 PM 04:51:37  
No. 105

[ REF RESULT ]

VD : 12.0 mm CYL : -

<R>	SPH	CYL	AX
AVE	-0.79	0.00	0.0
1	-0.80	0.00	0.0
2	-0.78	0.00	0.0
3	-0.81	0.00	0.0

<L> SPH CYL AX

AVE	-0.82	-0.34	107.8
1	-0.81	-0.36	111.2
2	-0.83	-0.33	107.0
3	-0.83	-0.33	105.1

[ KER RESULT ]

<R>	mm	D	AX
AVE	7.48	7.46	47.8
1	7.46	7.46	0.0
2	7.50	7.45	143.3
3	7.47	7.47	0.0

<L> mm D AX

AVE	7.42	7.33	35.6
0	7.43	7.32	31.2
1	7.40	7.33	29.5
2	7.42	7.34	46.0

Callouts in the image:

- Recognizing of measurement date (points to 2017-08-17 PM 04:51:37)
- Recognizing of measurement mode (points to [ REF RESULT ])
- Recognizing of measurement average value (points to the AVE row in the <R> table)

[ Drawing 10 ] Print Sample



Iris has damaged on Some of IOL patient. If damage is deep, measurement result may have some error.

## 10. Self Inspection and Maintenance

### 10.1 Before Calling a Service Person

Warning messages will be displayed on the monitor if some problems occur. It might be operation errors or problems of the machine. In this case, refer the following instructions. If the function is still not salvaged or recovered, disconnect the power supply and consult the dealer.

#### (1) Message When Power On

Message	Cause	Remedy
FOG MOTOR FAIL	Internal error	Turn OFF the power switch and turn on again after 10 seconds. If the message appears again, consult the dealer.
SHUT MOTOR FAIL		
Measure Error	Internal error	- Try to re-measure if measurement fails. - If frequency is frequent, contact the CS team by attaching the number.

#### (2) Message On Measuring

Message	Cause	Remedy
RETRY	Alignment is improper	Measure after aligning the pupil and the Alignment Mark properly.
	Eyelid or eyelashes are covering the pupil.	Instruct the examinee to open his or her eyes wide, or lift up the eyelid lightly with your fingers and measure again
	When the pupil is smaller than the Outer Alignment Mark.	The minimum pupil diameter that can be measured is 2.0 mm. Although it is possible to measure in the bright place, don't expose examinee's eyes to the direct sunlight or too bright indoor lights to prevent the contraction of the pupil.
	When the examinee has some illness like cataract.	Observe the eye in SIZE Mode. If cataract is not severe, measurement can be performed in the IOL mode.
	Examinee has IOL (intraocular lens) implanted.	Measure in the IOL mode.
	When the Mire Image is odd shaped because of tears.	Instruct the examinee to open and close his or her eyes several times and measure again.
	When the Mire Image is not clear because the cornea is dry.	
	Examinee has strong irregular astigmatism or corneal disease.	Impossible to measure
AGAIN	Measurement result is not reliable.	Measure again.

OUT+ OUT-	Data was out of valid measurement range.	Measurement result is unreliable. Please measure again.
--------------	--	---

(3) Message On Printing

Message	Cause	Remedy
NO PAPER	Empty printer paper.	Replace the printer paper.

(4) Error during measurement

Error	Cause	Remedy
When power is applied, only the UniCos logo is displayed.	Internal error	<ul style="list-style-type: none"> <li>- Insert the USB stick that stores the file (Cosmos8) needed for the update and reboot.</li> <li>- Ask the manufacturer or supplier for the file.</li> </ul>

## 10.2 Fuse Replacement

The power protection fuse protects the product from excess current. If the power monitoring protection circuit detects excess current, it shut off the current to the equipment in order to prevent overheating and to restrict the SMPS power output.

	<p>To avoid risk of electric shock, always disconnect the plug from the system prior to fuse replacement.</p>
---	---

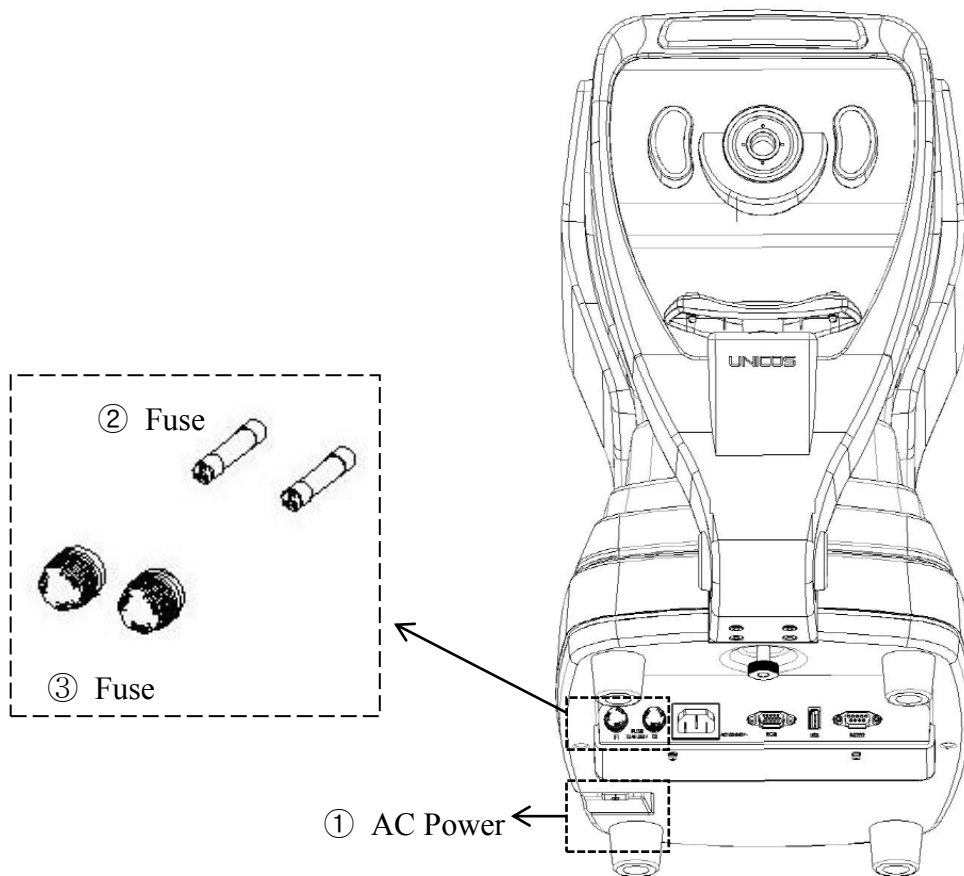

1. Turn off the system and disconnect the system power cord from the wall outlet.
2. Release the fuse holder by using the flat head screwdriver.
3. Remove the old fuse and replace it with a new one.
4. After installing the new fuse, connect the plug to the product.

※ Fuse information is shown in the following table

Input Ratings	Fuse Ratings	Maker	Order No.
100~120 VAC	2AH/250V	Littelfuse	216_code002
200~240 VAC	2AH/250V	Littelfuse	216_code002

### 10.3 Service Information

(1) Repair

If problem cannot be solved even after taking the measures indicated in section 12.1, contact URK-800A representative or distributor for repair.

Please refer to the name plate and let us have the following information:

- Name of the instrument : URK-800A
- Serial Number : 9-digit characters indicated on the name plate
- Phenomenon : In detail
- Size : 79mm(W) x 31mm(D)



[Drawing 34 ] Labeling

(2) Limit for Supplying Performance Parts for Repair

Performance part (required to maintain the functioning of the product) of this product will be stocked for six years after discontinuation of product, to allow for repair

## 11. Specifications

Refractometry		
Vertex Distance(VD)	0.0 , 10.0, 12.0, 13.5, 15.0mm	
Sphere(SPH)	-25.00 ~ +22D (VD 12mm)	Unit : 0.12 / 0.25 D
Cylinder(CYL)	0.00 ~ ±10.00D	Unit : 0.12 / 0.25 D
Axis(AX)	1 ~ 180°	Unit : 1°
Cylinder form	-, +, MIX	
Pupil Distance(PD)	10 ~ 85mm	
Minimum Pupil Diameter	Ø2.0mm	
Keratometry		
Radius of Curvature	5.0 ~ 10.2mm	Unit : 0.01mm
Corneal Power	33.00 ~ 67.50D	Unit : 0.12/ 0.25 D
Corneal Astigmatism	0.00 ~ -15.00D	Unit : 0.12/ 0.25 D
Axis	1 ~ 180°	Unit : 1°
Corneal Diameter		
Corneal Diameter	2.0 ~ 12.00mm	Unit : 0.1mm
ETC.		
Storage Memory	10 measurement each eyes	
Internal Printer	Thermal printer	
Display	7.0 inch TFT COLOR LCD Monitor, Touch	
Chin rest movement	Max 65mm, electrical movement	
Operation environment	Temperature : +10℃ ~ +40℃ Humidity : 30% ~ 80% RH Atmospheric pressure range : 70 kPa ~ 106 kPa Shock (without packaging) : 10g / 6ms	
Storage and Movement environment	Temperature : +10℃ ~ +55℃ Humidity : 10% ~ 90% RH Atmospheric pressure range : 50 kPa ~ 106 kPa Shock : 30g / 6ms Permanent shock : 10g / 6ms Oscillate(sine curve) : 10Hz ~ 500Hz, 0.5g	
Power supply	AC100V ~ 240V, 50/60Hz	
Power consumption	60 - 90VA	
Dimension	275mm(W) x 525mm(D) x 450mm(H)	
Weight	18kg	

## 12. ACCESSORY

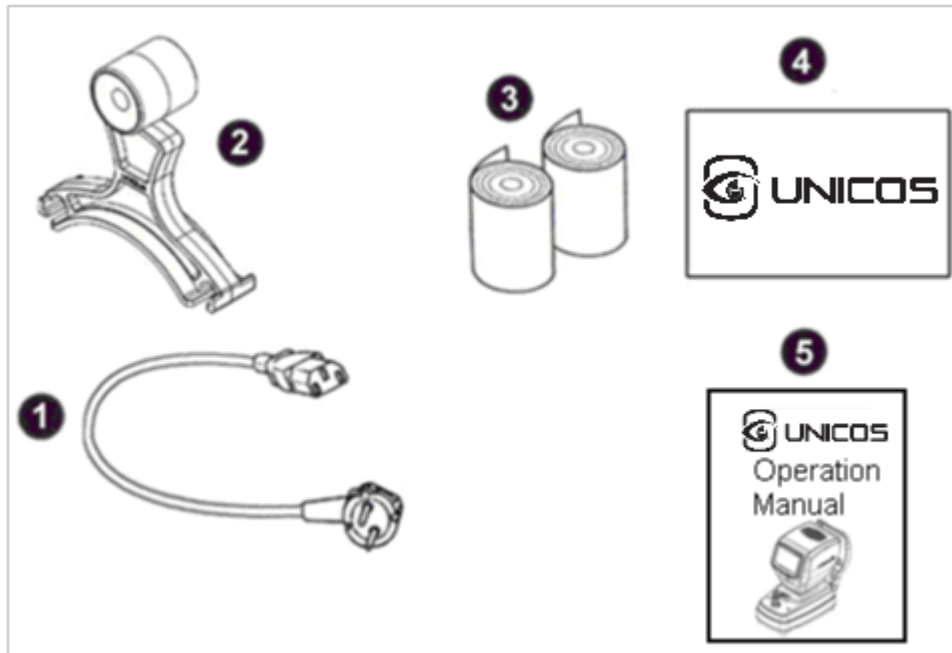

[ Drawing 35 ] URK-800A Accessory

Name	Standard	Quantity
① Power Supply Cable	H05VV-F 175mm, 3G 0.75mm <sup>2</sup> , 175mm	1EA
② Model Eye	Diopters : 1.5168, 110mm X 105mm X 35mm	1EA
③ Printing Paper	T 12 * 57 * 50 mm	2 rolls
④ Dust cover	260mm(W) X 490mm(D) X 475mm(H)	1EA
⑤ Operation Manual	B5(254mm X 180mm)	1EA



## 13. Packing

### 13.1 Packing Foam Design

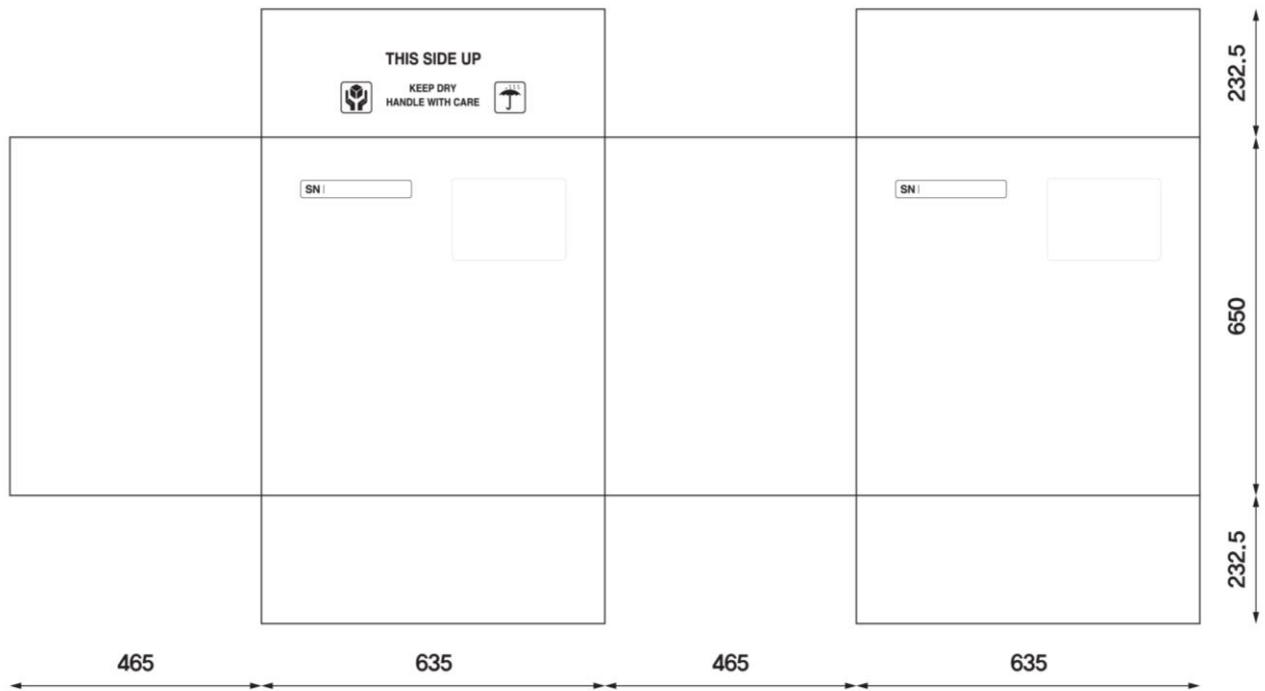









[ Drawing 36 ] URK-800A Packing Box



[ Drawing 37 ] URK-800A Packing Box Sticker

### 13.2 Packaging step

Step 1	Plastic bag packaging Material : PE Size : 0.4Tx750x1300 Color : transparency	
Step 2	Foamed polystyrene packaging Material : poly urethane Size : 635x650x232.5 ( pair) Color : Silver	
Step 3	Paper box packaging Material : KLB225.CK.K.CK.KLB225 Size : 635x650x465 Color : 1 degree black, yellow	
Step 4	Rope packaging Material : P.P Size : 15mm Color : yellow	
Step 5	Finish packaging	

	<ol style="list-style-type: none"> <li>1. Be cautious not to fall down or not to drop when carrying.</li> <li>2. Be cautious not to be hurt on your finger when holding the rope to carry.</li> <li>3. Please contact manufacturer or distributor if the packing box is damaged because it may damage a equipment.</li> <li>4. Please contact manufacturer or distributor if it's contaminated by rainwater because it may damage a equipment or it may present a risk of electric shock.</li> </ol>
	<ol style="list-style-type: none"> <li>1. Please use gloves when unpacking box.</li> <li>2. The Cutting rope may be put injury keep both the line hold the demolition.</li> </ol>
	<ol style="list-style-type: none"> <li>1. Do not store and move the packing box being upside down.</li> <li>2. Do not put heavy things over 20Kg.</li> <li>3. Do not throw it or fall or pick up from high.</li> </ol>

## 14. EMC (ELECTROMAGNETIC COMPATIBILITY)

The Electromagnetic Compatibility Directive sets the essential requirements for electrical and electronic equipment that may disturb or even be disturbed by other equipment. The URK-800A complies with these requirements as tabled below. Follow the guidance on the tables for use of the device in the electromagnetic environment.

### EMC Information (IEC 60601-1-2:2014)

Emissions		
Test items	Standard	Limit
Conducted emissions	CISPR 11	Group 1 Class B
Radiated emission	CISPR 11	Group 1 Class B
Harmonics Current Emission	IEC 61000-3-2	Class A
Voltage fluctuations and Flicker emissions	IEC 61000-3-3	Pst: 1 Plt: 0.65 Tmax:0.5 dmax: 4% dc: 3.3%

Immunity		
Test items	Standard	Test level
Electrostatic discharge	IEC 61000-4-2	± 8 kV/Contact, ± 2, ± 4, ± 8, ± 15 kV/Air
Radiated RF electromagnetic field	IEC 61000-4-3	10 V/m 80 MHz-2.7 GHz 80% AM at 1 kHz
Electrical fast transient/Burst	IEC 61000-4-4	AC Mains: ± 2 kV, 100 kHz repetition frequency I/O Lines: ± 1 kV, 100 kHz repetition frequency
Surge	IEC 61000-4-5	Line to Line ± 0.5 kV, ± 1 kV  Line to Ground ± 0.5 kV, ± 1 kV, ± 2 kV
Conducted disturbances induced by RF fields	IEC 61000-4-6	3 V 0.15-80 MHz 6 V in ISM & Amateur radio bands Between 0.15 MHz and 80 MHz 80% AM at 1 kHz
Power frequency magnetic field	IEC 61000-4-8	30 A/m, 50 & 60 Hz
Voltage dips	IEC 61000-4-11	0 % $U_T$ ; 0.5 cycle At 0°, 45°, 90°, 135°, 180°, 225°, 270° and 315° 0 % $U_T$ ; 1 cycle and 70 % $U_T$ ; 25/30 cycles Single phase: at 0°
Voltage interruptions	IEC 61000-4-11	0 % $U_T$ ; 250/300 cycle

Immunity to radiated radio frequencies, caused by wireless communications equipment in accordance with IEC 60101-1-2:2014				
Standard	Band [MHz]	Service	Modulation	Test level [V/m]
IEC 61000-4-3	385	TETRA 400	Pulse modulation 18 Hz	27
	450	GMRS 460, FRS 460	FM $\pm$ 5 kHz deviation 1 kHz sine	28
	710	LTE Band 13, 17	Pulse modulation 217 Hz	9
	745			
	780			
	810	GMS 800/900, TETRA 800, iDEN 820, CDMA 850, LTE Band 5	Pulse modulation 18 Hz	28
	870			
	930			
	1720	GSM 1800, CDMA 1900, GSM 1900, DECT, LTE Band 1, 3, 4, 25, UMTS	Pulse modulation 217 Hz	28
	1845			
	1970			
	2450	Bluetooth, WLAN, 802.11b/g/n RFID 2450, LTE Band 7	Pulse modulation 217 Hz	28
	5240	WLAN 802.11a/n	Pulse modulation 217 Hz	9
	5500			
	5785			

**CAUTION – GENERAL HAZARDS**

Portable and mobile RF communications equipment may affect the device. When operating radio devices or components for radio transmission.

"Portable RF communication equipment (including peripherals such as antenna cables and external antennas) should be used no closer than 30 cm to any part of the URK-800A including cables specified by the UNICOS. Otherwise, degradation of the performance of this equipment could result"

**CAUTION – HAZARDS DUE TO ELECTROMAGNETIC INTERFERENCE RADIATION**

The URK-800A may not be placed next to or stacked together with other equipment, except in the device configurations described in this user manual. If operation close to or together with other devices is necessary, the URK-800A must be closely observed in order to monitor its proper functioning in this configuration.

**CAUTION – REPLACEMENT CABLES MAY ONLY BE PURCHASED AT UNICOS**

The use of accessories, all types of transducers and cables not specified in this user manual or not sold by UNICOS as replacement part may result in higher emissions or reduced immunity of the URK-800A

## 15. Disposal of waste products

When disposing of the products below to contact us

COMPANY : UNICOS Co., Ltd

Address : 282-30, MUNJI-RO, YUSEONG-GU, DAEJEON, KOREA

Tel : +82-42-825-8045

Fax : +82-42-581-0053

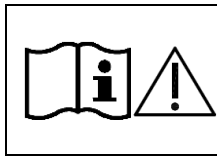

This instrument incorporates a lithium battery, which may pollute the environment if the instrument is disposed.  
Please ask a professional waste disposal company to handle disposal or your distributor before disposing of the instrument.