

MANUAL LENS METER
MANUAL

LR-20



Contents

1. Description and Uses of Device Model	3
2. Main Technical Indexes	3
3. Principle of Operation	4
4. Functions of Major Components	5
5. Operation Instruction.....	11
5.1 Preparation before Measurement	11
5.2 Points for Attention in Operation.....	11
5.3 Placement of Lens	11
5.4 Measurement of Spherical Lens.....	12
5.5 Measurement of Sphero-Cylindrical Lens	12
5.6 Measurement of Prism Lens.....	14
5.7 Demarcation of Lens.....	15
6. Maintenance of Instrument	15
7. Common Trouble Shooting.....	16

1. Description and Uses of Device Model

This lens meter is divided into 2 models, standard model and strengthened model with prism compensator.

This product is applicable to measurement testing departments, spectacles manufacturers, retail dealers of spectacles, hospital's department of ophthalmology and optical element factories for conducting measurement of spherical lens diopter, cylindrical lens diopter, and cylindrical lens axis of astigmatism, prism diopter, prism basal angle and cornea contact lens diopter. In the following description, all chapters or content attached with "*" in the front are special for strengthened model device with prism compensator.

2. Main Technical Indexes

1. Ranges of diopter measurement	0	+25D	
Minimum scale value	0.1	25D at 0	+5D
	0.25D	at ±5D	±25D
2. Astigmatism axis of cylindrical lens	0	180°	
Minimum scale value	1°		
3. Prism diopter standard model	0	5Δ	
Minimum scale value	1	Δ	
*Strengthened model	0	20Δ	
*Minimum scale value	1	Δ	
4. Prism base angle	0	-180°	
Minimum scale value	1°		
5. Regulation of ocular visibility	±5D		
6. Size of lens	∅16mm	∅80mm	
7. Overall dimensions of device	275mm	X 130mm	X 455mm
8. Weight standard model	5.6kg		
*Strengthened model	5.7kg		
9. Lighting lamp	220V/11	0V15W	

3. Principle of Operation

Fig.1 Diagram of Optical Principle

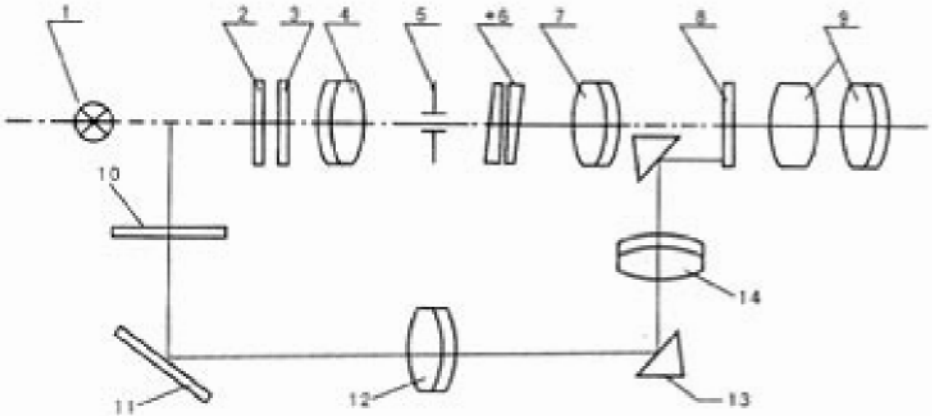

1. Light source
2. Color filter
3. Marker reticule
4. Measuring objective lens
5. Diaphragm
- *6. Prism compensation device
7. Objective lens
8. Eyepiece reticule
9. Eyepiece
10. Reading division board
11. Reflect lens
12. Front lens
13. Right angle prism
14. Back lens

This instrument consists of two coaxial optical systems. Light sent out from light source 1 (lighting bulb) passes through color filter 2 to lighten marker reticule 3. Through measuring objective lens 4 and objective lens 7, marker reticule 3 forms its image in eyepiece 8. Meanwhile, the optical reading reticule 10 forms its image on eyepiece 8 through front lens 12 and back lens 14. At this time, human eyes are able to clearly observe the images of reticule 3 eyepiece 8 and reading reticule 10.

During the operation, place lens at position of diaphragm 5 (Objective lens bearing seat), turn and axially move marker reticule 3 so that it is imaged clearly. Then the scale interval shown on the reading division board 10 is just the numerical value of diopter.

4. Functions of Major Components

4.1 Eyepiece (Fig.2)

Eyepiece section is equipped with a spiral focusing unit whose range of focusing is $\pm 5D$ so as to suit different eyesight's of people.

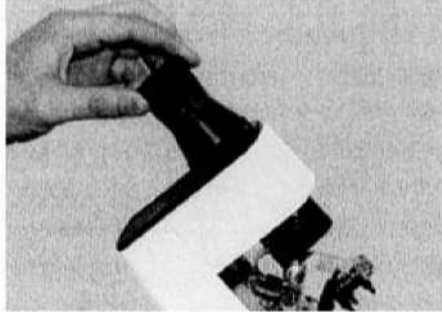

Fig. 2

4.2 Eyepiece reticule and marker reticule (Fig.3, Fig.4)

Reticule in the field of view of eyepiece is shown as Fig.3. On the reticule is divided with measuring scale and dividing disc of prism degree. Integer degree of prism is directly read on the measuring scale and decimal one estimated according to the degree on the measuring scale. The dividing disc is ruled with an interval of 5° . The marker reticule is shown as Fig.4, 3 long green lines are in the horizontal position.

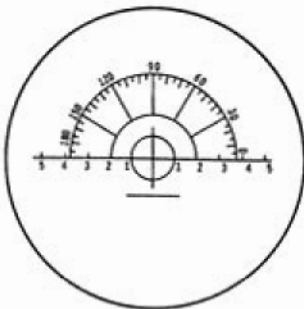

Fig.3

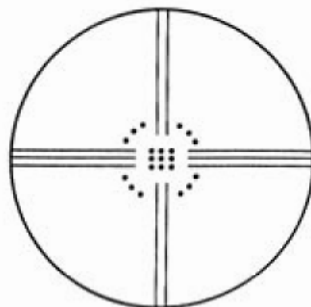

Fig.4

4.3 Reading division board (Fig.5)

In eyepiece 9's field of vision, the reading window is in the lower part of eyepiece reticle 8. The range of reading reticle is ± 25 D. The graduations between 0 and ± 5 D are at an interval of 0.125 D; those between ± 5 D and ± 25 D are at interval of 0.25 D.

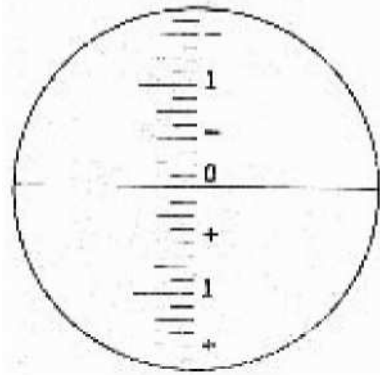

Fig. 5

*4.4 Prism compensation device (Fig.6)

MODEL LM 190 P

The prism compensation device is needed when measuring lens diopter above 5Δ . There are two lines of graduations on the prism compensation device. The upper line is angle between 0° and 180° at 5° intervals. The lower line is the prism diopter in the range of $15 -0- 15 \Delta$ at 1Δ interval.

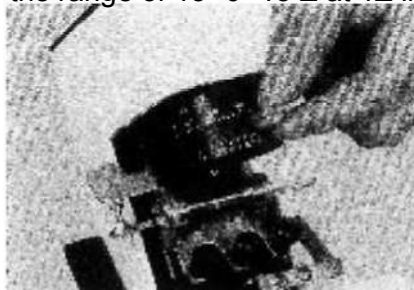

Fig. 6

4.5 Lens pressing unit (Fig.7)

In the unit, 3 plastic pressing feet with springs are used to press lens so that surface of lens with any shape can be pressed stably and no lens surface will be bruised. When it is operated, lift the lens pressing bracket so that the lens pressing unit lowers to press the lens. After using it, raise the lens pressing unit and then the lens pressing unit is hung.



Fig. 7

4.6 Lens pushing unit (Fig.8)

The unit is used to fix the position of lens. During operation, turn backwards the lens pushing handle and then the lens pushing board is pushed out forwardly. After use, turn forwards the lens pushing handle to withdraw the lens pushing board. During measurement, first press the lens with the lens pressing unit and slightly move the lens so that it aims right at center, then fix it with the lens pushing unit.

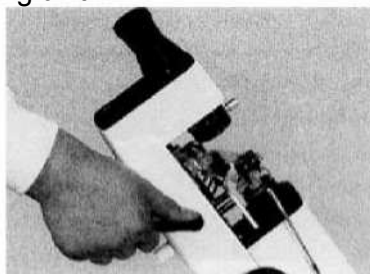

Fig. 8

4.7 Printing unit (Fig.9)

The unit has 3 identical point-making pens connected in line, the pen in the middle is used to set center of lens and the connected line of printing points made by these 3 pens are used to demarcate angle of axis of astigmatism and base angle of prism lens. When printing is needed, turn holder of Point-making pens and apply ink to the front ends (a small convex) of 3 pens, then it is very convenient for people to print the ink on the lens swiftly.

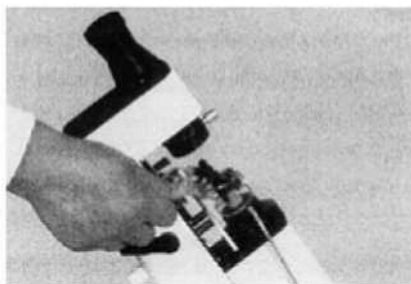

Fig. 9

4.8 Objective lens bearing seat (Fig.1 0)

It is a white nylon part which is able to stably support surface of any shape of lens without bruising lens surface. Objective lens is shown below, and there are 3 lock screws nearby.

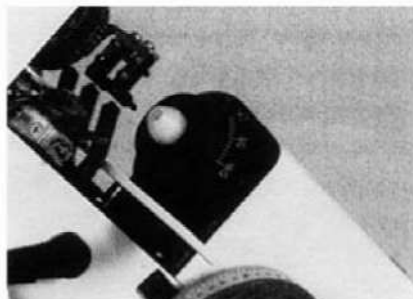

Fig. 10

4.9 Diopter measuring hand wheel (Fig.1 1)

There is a diopter measuring hand wheel at either side of this instrument. They can be rotated smoothly and steadily. During the measurement, rotate one hand wheel to adjust the focus till you clearly see the indication of the lens diopter through the reading window.

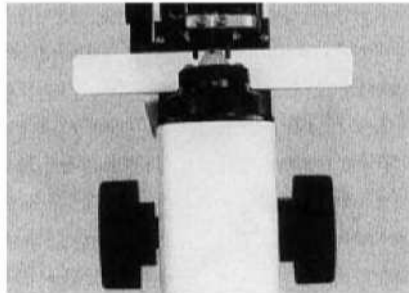

Fig. 11

4.10 Astigmatism axis measuring hand wheel (Fig.1 2)

It is used to measure and fix angle of astigmatism axis of cylindrical lens and base angle of prism lens.

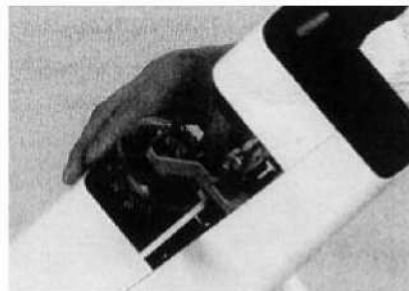

Fig. 12

4.11 Illuminating bulb chamber (Fig.1 3)

Open the lower cover of the device; one can easily and quickly change the bulb.

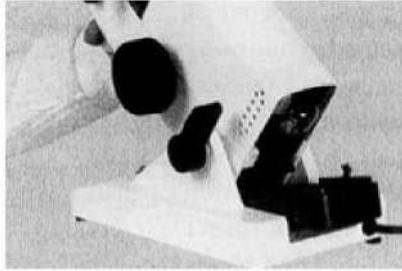

Fig. 13

4.12 Instrument's inclination regulating handle (Fig.1 4)

It allows operator to freely regulate inclination of instrument so that he (she) is able to work at a comfortable posture. After screwing out the handle, the operator can incline the device to a required angle according to the state of working table, and then lock the handle.

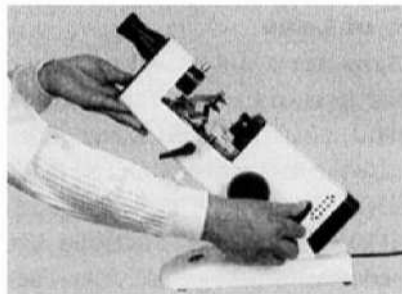

Fig. 14

5. Operation Instruction

5.1 Preparation before Measurement

5.1.1 Place the instrument on the working table and adjust inclination of the instrument so that operator is able to make a measurement comfortably.

5.1.2 Connect with the mains.

5.1.3 Regulation of eyepiece's visibility. Before measurement, visibility of eyepiece shall be regulated in order to get accurate and reliable results of measurements. Method: While observing black cross dividing line of eyepiece reticule 8 in the view field of eyepiece, rotate eyepiece cover in one way (one-way rotation can remove influence due to regulation effect of eyes) until the black cross line gets clearest.

5.1.4 Regulation of zero position of instrument. Rotate diopter measuring hand wheel to regulate scale interval to zero position and observe green dividing line of marker reticule 3 in the view field of eyepiece. At this time, the green dividing line is clearest.

5.2 Points for Attention in Operation

5.2.1 A measured person who has relatively deep diopter or astigmatism of eyes shall wear glasses to correct defects of vision. Only after that, can measurement be carried out.

5.2.2 Among the green dividing lines, 2 longer ones are spherical marking lines and 3 longer ones are cylindrical marking lines.

5.2.3 To achieve the most accurate measuring results, it would be best if one rotate the diopter measuring hand wheel in one way. The direction of rotation is $-25D + 25D$.

5.3 Placement of Lens

5.3.1 Lens should be placed on the objective lens bearing seat with concave facing downwards. The upper edge of lens assembled on the lens frame (i.e. beam edge of lens frame) should be leaned against the lens pushing board.

5.3.2 Lightly release the lens pressing unit so that the pressing feet press the lens slightly.

5.3.3 Regulation of lens center. Observe it through eyepiece and rotate diopter measuring hand wheel to make green dividing line of marker reticule 3 clearest. At the same time, move the lens so that the green dividing line of marker reticule 3 and center of black cross dividing line of eyepiece reticule 8 coincide.

5.4 Measurement of Spherical Lens

Rotate diopter measuring hand wheel so that green dividing line of marker reticule 3 becomes clearest. Then scale interval on the reading window is the spherical diopter of the said lens.

5.5 Measurement of Sphero-Cylindrical Lens

Sphero-Cylindrical Lens means astigmatic lens. Normally its outer surface is spherical and inner surface is cylindrical or drum-typed (i.e. internal astigmatism). Each section of the internal surface has different refractive power, in which 2 mutually vertical sections have weakest refractive power and strongest refractive power.

When this instrument is used to measure such kind of lens, 2 long green lines and 3 long green lines of marker reticule 3 will not get clear simultaneously. Measurement is made in 3 steps:

The first step: Rotate diopter measuring hand wheel so that the torus (composed of 12 small green dots) is imaged into clear looped short cylindrical lines. Then rotate astigmatic axis measuring hand wheel again, so that spherical marking line (2 long green ones) and torus short lines are in the same direction. At the same time, conduct fine tuning of the diopter measuring hand wheel to make 2 long lines clearest. Now write down a reading value of diopter.

The second step: Rotate diopter measuring hand wheel again so that cylindrical marking lines (3 long green ones) are focused to be clearest and in the same direction of the torus short lines. Now write down again a reading value of diopter, and also note down the reading value of the lens' angle of astigmatism axis on the astigmatism axis measuring hand wheel (which can be also read off according to eyepiece reticule 8).

The third step: Calculation of the degree of astigmatism. Subtracting reading values of the diopter of above-stated 2 times is just the astigmatism degree of the said lens.

Diopter of a sphere-cylindrical lens may be written in various forms, where, spherical diopter may be expressed as low luminosity or high luminosity, and cylindrical diopter (i.e. astigmatic degree) expressed as a positive or negative number. This can be done simply by way of luminosity transformation.

In this operation instruction, spherical diopter is assumed to be low luminosity. The procedures of measurement are shown as follows:

a. Calculation of spherical diopter. Focus spherical marking lines (2 long green ones) clearly. Please note that there will be 2 reading numbers.

Rotate diopter measuring hand wheel and, at the same time, rotate astigmatism axis measuring hand wheel, focus spherical marking lines (2 long green ones) clearly and write down a reading value of diopter. Then rotate astigmatism axis measuring hand wheel by 90° , focus spherical marking lines (2 long green ones) clearly again and note down a new diopter reading value. Compare reading values of 2 times and take a reading value with smaller absolute value (i.e. low luminosity) as the spherical diopter of the said lens.

- b. After fixing spherical diopter, rotate diopter measuring hand wheel again to focus cylindrical marking lines (3 long green ones) clearly. Write down the diopter reading value (high luminosity) at this moment.
- c. Difference of the readings in 2 times is the astigmatism degree of the said lens and its axis direction is directly read off according to astigmatism axis measuring hand wheel.

Example 1: Calculation of +1 DS-3.5DC X 30°

The first step: Rotate diopter measuring hand wheel and, at the same time, rotate astigmatism axis measuring hand wheel to focus spherical marking lines clearly. Now the measured data are: diopter +1 D, axis angle 30° . Then rotate astigmatism axis measuring hand wheel by 90° to focus spherical marking lines clearly. Now the measured data are: diopter -2.5D, axis angle 120° . Take +1 D as spherical diopter.

The second step: Rotate diopter measuring hand wheel and, at the same time, rotate astigmatism axis measuring hand wheel to focus spherical marking lines clearly once more. Now the reading on the reading window is +LD, which is the reading at the first time. Then rotate the diopter measuring hand wheel to focus cylindrical marking lines clearly. At this time, the reading on the reading window is -2.5D, which is the reading at the second time.

The third step: $(-2.5D) - (+1D) = -3.5D$, i.e. astigmatism degree is -3.5D and axis direction is directly read off according to astigmatism axis measuring hand wheel, which is 30° , as shown in Fig. 15 and Fig.16.

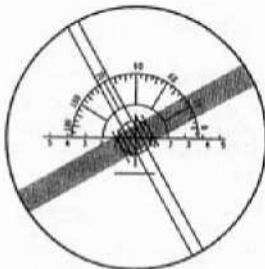

Fig. 15 Image at 1D

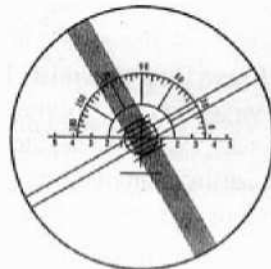

Fig. 16 Image at -2.5D

Illustration: $+1 \text{ DS}-3.5\text{DC} \times 30^\circ$ can be converted into $-2.5\text{DS}+ 3.5\text{DC} \times 120^\circ$, and can be also measured using this instrument, which will not be described here again.

5.6 Calculation of Prism Lens

5.6.1 Measurement of diopter below 5Δ

Place prism lens on the objective lens bearing seat and aim its optical center at center of objective lens bearing seat (i.e. optical axis). Rotate diopter measuring hand wheel to focus lines of marker reticule 3 clearly, the marking lines can be seen to deviate from center of eyepiece reticule 8. The deviating direction is the base direction of prism eyeglass. Rotate astigmatism axis measuring hand wheel so that the middle one of 3 long green marking lines passes through the center of eyepiece reticule 8, thus value of base angle of prism lens can be read off according to astigmatism axis measuring hand wheel. Prism diopter can be estimated according to the reading on eyepiece reticule 8, as shown in Fig. 17.

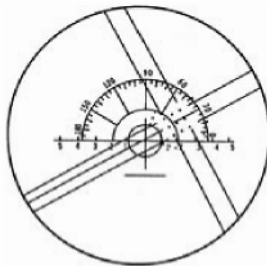

Fig. 17

In the figure: Diopter of prism lens is estimated at 2Δ and dividing line image of marker reticule 3 deviates by 30° to upper right side. Measured data of the said prism lens include prism diopter 2Δ and base angle 30° .

*5.6.2 Measurement of diopter above 5Δ

The prism compensation device is needed when measuring lens diopter above 5Δ . Rotate the diopter measuring hand wheel and turn the angle to adjust the division line on marker reticule 3 to the proper position. Then you get two reading from eyepiece reticule 8 and the prism compensation device. The sum of the two numbers is the prism diopter of the lens; the base angle can be read from the prism compensation device.

5.7 Demarcation of Lens.

5.7.1 Determination of the optical center of 2 assembled lens

Place the glasses on the instrument. First choose any one of glasses and rotate diopter measuring hand wheel to make it in focus, at the same time, lightly move glasses frame so that the focused-image is at the center of optical axis and make a center printing mark on the lens by the use of printer.

Then repeat the operation to print a mark on another lens. Now simply measure the distance between center printing marks of these 2 lens by the use of slide caliper.

5.7.2 Demarcation of spherical lens

a. Rotate diopter measuring hand wheel to focus lines of marker reticule 3 clearly.

b. Lightly move the lens to find the right optical center.

c. Make 3-point printing marks by the use of printer.

5.7.3 Demarcation of the axis of sphere-cylindrical lens

a. Rotate astigmatism axis measuring hand wheel to a required angle.

b. Rotate diopter measuring hand wheel and, at the same time, turn lens to focus cylindrical marking lines clearly.

c. Lightly move the lens to find the right optical center.

d. Make 3-point printing marks by the use of printer.

5.7.4 Demarcation of the base of prism lens

a. Rotate astigmatism axis measuring hand wheel to a required angle.

b. Rotate diopter measuring hand wheel to focus lines of marker reticule 3 clearly.

c. Lightly turn prism lens so that the middle one of 3 long green marking lines passes through center of the eyepiece reticule 8.

d. Make printing point marks by the use of printer.

6.1 Factory-adjusted control of the instrument has been carried out, please do not dismantle it at will so as not to influence its indicating precision.

6.2 The instrument should be used in a dry and air-circulated indoor place in Order to prevent the optical components from damping and mildewing.

6.3 After using it, clean the instrument and cover lens with dust shield.

6.4 Prevent the instrument from severe vibration or impact in order to avoid Damage & looseness of parts and components and guarantee the Measuring precision.

6.5 When you change the bulb, do not do it until the bulb is cool to avoid burning your hand.

6.6 Always keep the instrument clean. Touching surface of optical parts is strictly prohibited. Dust and stain on it shall be cleaned with absorbent

cotton dipped with mixture solution of ethanol and ether.

7. Common Trouble Shooting

Serial No.	Trouble	Reason	Solution
1	Bulb can't be lighted	Mains are not connected	Connect with mains
		Bulb is out of order	Change the bulb
2	Eyepiece reticule cannot be seen when adjusting the eyepiece readings	Degree of the measured person 's myopic eye is too deep or he (she) has astigmatism	Wear Glasses
3	Green marking image cannot be seen	Bulb cannot be lighted	Same as No. 1
		Dust shield is not taken off	Take off the dust shield
4	Green marking image cannot be seen clearly	Dust occurs on optical lens	clean it using absorbent cotton dipped with cleaning solution
5	Deviation of the center of green marking image	Loosening of lock screw	Take off objective lens protection shield and regulate 3 screws and lock them
6	Translocation of printing unit	Loosening of limit screw	Regulate limit screw and lock it
		Loosening of connecting screws	Regulate connecting screws and lock them

