

VIEWLIGHT
POWERED BY INNOVATION

Inami



NEW

Electrical Tables

.....
Table Tops - Not Included





ELECTRICAL TABLES & TABLETOPS

Designed for Slit lamps and Other Devices

Viewlight's sturdy electrical table features an adjustable workstation which facilitates 1 or 2 instrument configurations at a time and supported with secured on a stable platform.

EIT-16



Features:

- Table Size: 23.5" x 15.5"
- Designed for safe and reliable surface
- Included drawer size: 540mm x 320mm
- Maximum loading ability is about 75kg

Durable and Stable Tables

All Viewlight's electrical tables have built-in up and down switches for a smooth, functional and operating characteristics table top.

DT-EIT-16



Features:

- Facilitates 2 or 3 instrument
- Secured on a stable platform
- Painted by anti-scratch coating
- Table Top Made out of Wood



EIT-17 Electrical Table

EIT-17 electrical tables are generally used for slit lamp, keratometer, and other optical instrument, for stable and convenient operations. Displays a smooth adjustable height comes in 1 or 2 instrument configurations.

Features:

- Designed for safe and reliable surface
- Table Size is 400mm x 480mm x 8mm
- Drawer liner size is 540mm x 320mm
- Range of Elevation is 630 - 810mm
- Maximum loading ability is about 75kg.
- Up and Down electrical switch
- Easy to move, low noise, lifting up and down smoothly

EIT-20

Durable & Secured Workstation

Viewlight's electrical table EIT-20 offers a built-in up and down switches for a smooth, functional and operating characteristics table top.



Features:

- Secured tabletop
- Height adjuster
- Fits up to two devices
- Accessible keyboard support
- Double table top: 35" x 18.5"
- Range of Elevation: 640mm - 860mm

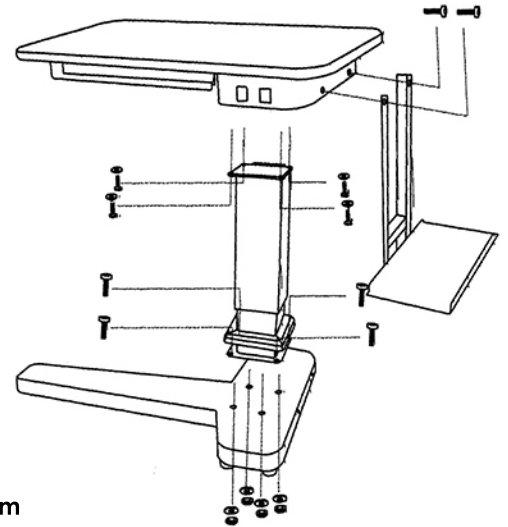

EIT-50

Design for 1-2 Devices

The EIT-50 electrical tables are generally used for slit lamp, keratometer, and other optical instrument, for stable and convenient operations. All Viewlight's electrical tables have built-in up and down switches for a smooth, functional and operating characteristics table top.



Features:

- Secured tabletop
- Height adjuster
- Fits up to two devices
- Accessible keyboard support
- Double table top: 30.5" x 19"
- Range of Elevation: 640mm - 860mm





VL-100-ST

Designed for LIFT - 02

Viewlight – The VL-100-ST is an all in one adjustable electrical table designed with a workstation that could hold up to 2 ophthalmic instruments, durable poll for a chart projector and a convenient drawer to compartmentalize all necessary tools.



Features:

- Adjustable workstation
- Facilitates 1 or 2 instrument
- Painted by anti-scratch coating
- Cogged Wheels
- Standard base is made by Die-cast aluminum



EIT-100

Multiple Workspace Station

The EIT-100 electrical table features a modern design with a strong and powerful quality. Fits up to 3 instruments with a maximum weight capacity of 350 lbs.

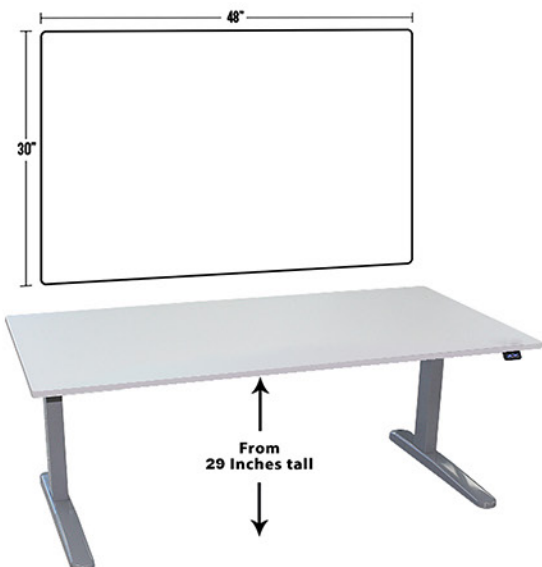
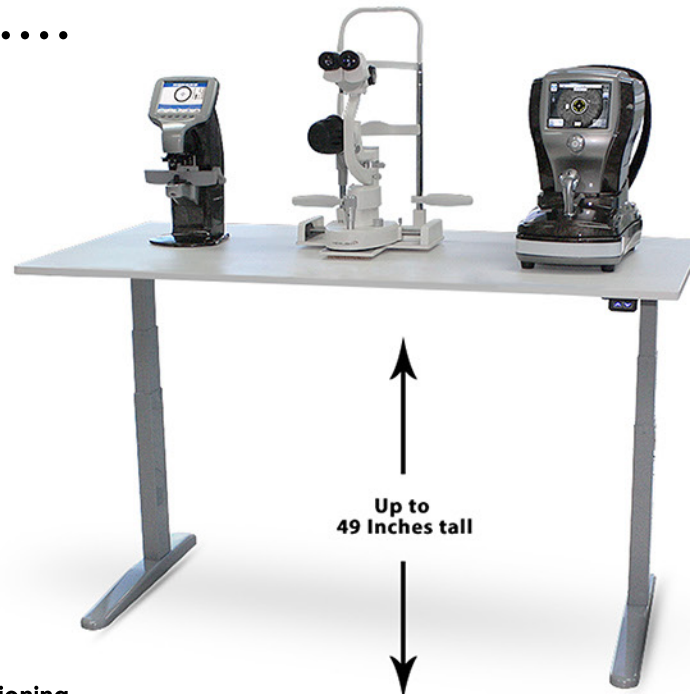

Features:

- Side-to-side positioning
- Wide frame - minimum width 42.25" Max 74"
- UP/DOWN buttons to move the desk to
- 4 Programmable memory presets (Optional)
- Auto-dark LED display goes black after 10 seconds
- Front-to-back position: 26.5" long
- Adjustable foot leveling studs
- MDF Tabletop - made of wood fibers
- Swivel Pencil Tray



ELECTRICAL TABLES - LIFT 01

The new ophthalmic electrical table LIFT 01 offers a "strong" design, obtained by the increasing of weight and dimension, the use of new material (no plastic), gives a modern and essential appearance.

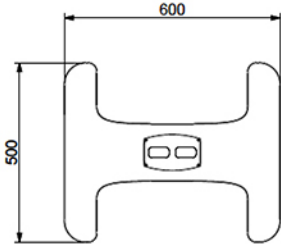

Features:

- Cogged Wheels
- Max thrust load: 1400N
- Adjusted Elevation Voltage: 100-240V
- Standard base is made by:
- Die-cast aluminum

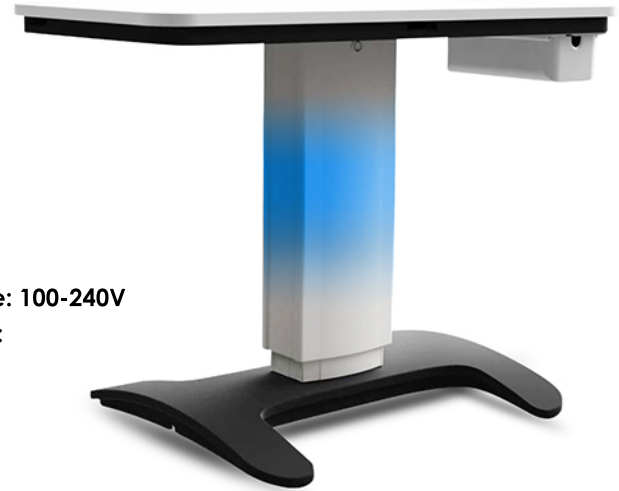

Table Top: TT-100710801 (Optional)

Single Device Operations

LIFT-01 is composed of an optional table top where it allows to place one device on its table top, cogged guides are already installed for the device housing.



Features:

- Made out of Wood
- Tools Compartment
- Max thrust load: 1400N
- Weight is 6.5kg
- Painted by anti-scratch coating
- Power cable connection
- Keyboard Connection

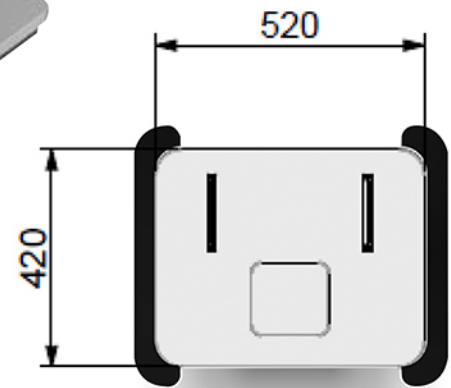

Table Top: TT-100710803 (Optional)

Device & Monitor Workspace

A sturdy single top electrical table TT-100710803 features an adjustable workstation which facilitates 2 or more instrument configurations at a time and supported with secured on a stable platform.

Features:

- Complete table top 40x50
- Table Top Made out of Wood
- Painted with anti-scratch coating
- Convenient accommodation drawer

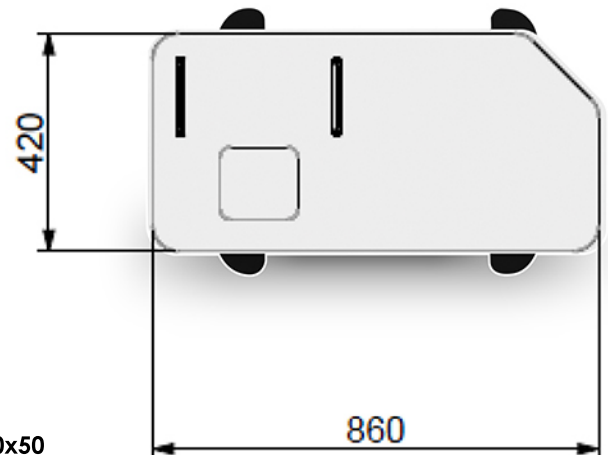



Electrical Tables - LIFT -02

The new ophthalmic electrical table LIFT 01 allows to place one device on its table top, whose elevation can be adjusted.

Features:

- Cogged Wheels
- Max thrust load: 1400N
- Adjusted Elevation Voltage: 100-240V
- Standard base is made by:
- Die-cast aluminum

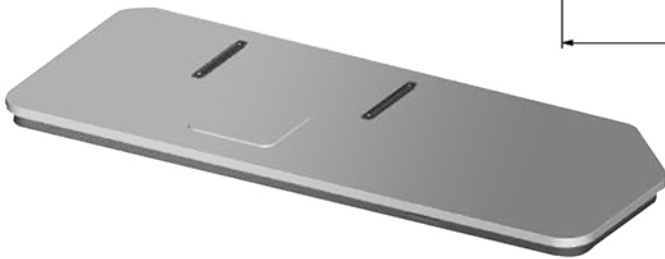
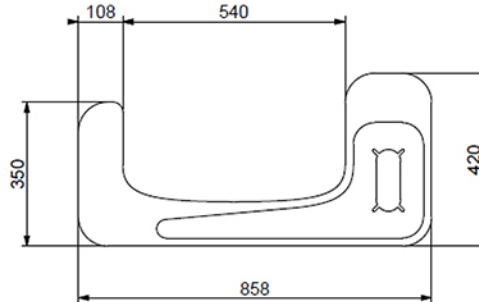

Table Top: TT-100710805 (Optional)

Device & Monitor Workspace

LIFT-01 is composed of an optional table top where, cogged guides are already installed for the device housing.

Features:

- Made out of Wood
- Tools Compartment
- Power cable connection
- Keyboard Connection
- Painted by anti-scratch coating

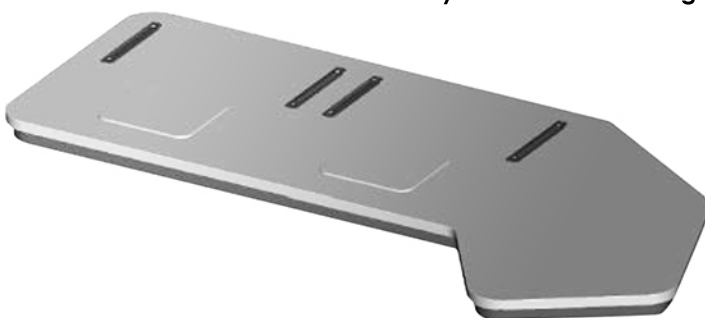
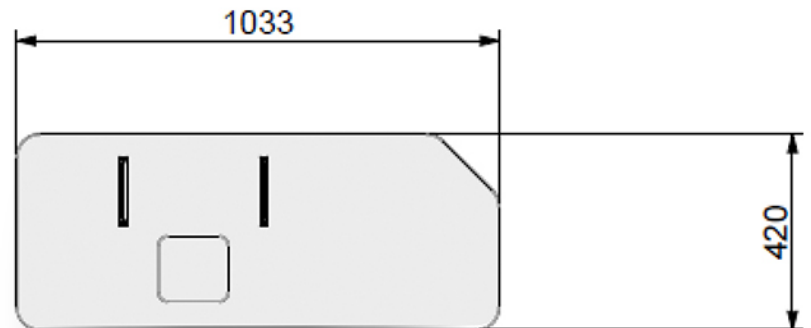
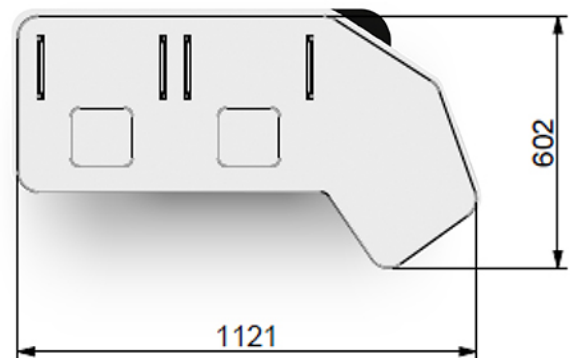

Table Top: TT-100710807 (Optional)

Two Device Operations

Features a convenient retinoscopy rack lens set VL-4704 is easy to carry and comes with a professional wooden handle and four wood racks,



K-1425-PT

Designed for 1-2 Workstation

The sturdy electrical table K-1425 offers an adjustable height which comes in 1 or 2 instrument configurations. Displays a rugged construction, designed slit lamps and other optical devices, which allows you peace of mind in knowing your instruments are secured on a stable platform.

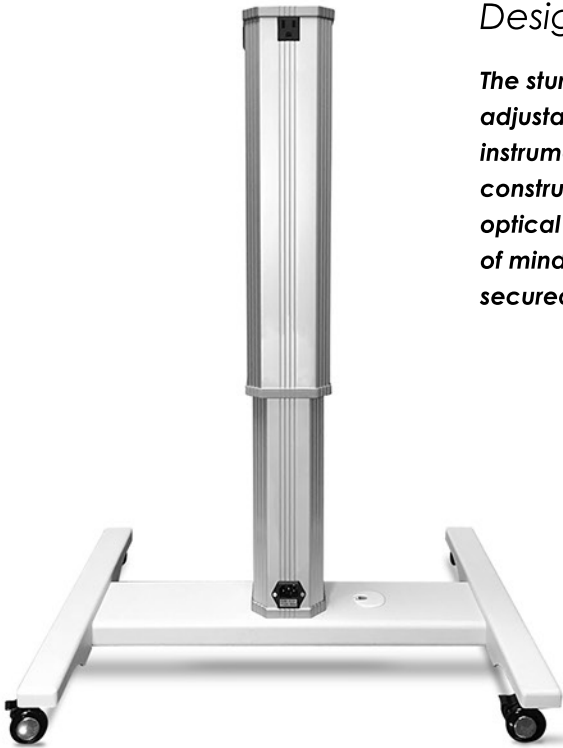

Features:

- Table Top Made out of Wood
- Greatly reduces optical strain
- Elevation Range: 600-850 mm
- Input Voltage is AC220V
- Consumed Power is 700W
- Up and Down Electrical switch

EIT-16 & DT-EIT16

Optional Table Tops

- Advanced technology designed for safe and reliable surface
- Light weight, easy to move and smooth adjustable transitions.
- Accessories screws, wrench, and plastic drawer are available
- Table Size is 600mm (W) x 450 (D)
- Maximum loading ability is about 50kg.
- Single Station: 23.5" x 15.5"
- Double Station: 35" x 18.3"



EIT-16



DT-EIT-16



Casters:

High quality lockable lock system and vibration resistant casters that ensure durability



Outlets:

Inami offers two electrical outlets designed for multiple ophthalmic devices while operating comfortably and in an organized fashion.



Switches:

Inami's electrical tables provides a built-in up and down switches for a smooth, functional & operating characteristics table top.